



Målskitser/Dimensional Sketches/ Massblätter

ROTAN® GP/HD/PD/CD/ED

Industry/Utility

DESMI
Make life flow

ROTAN® HD

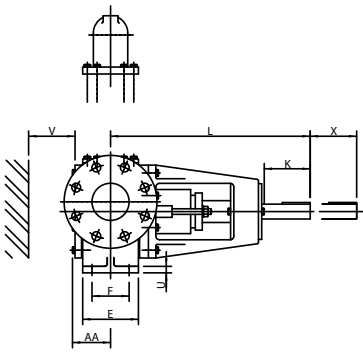

ER

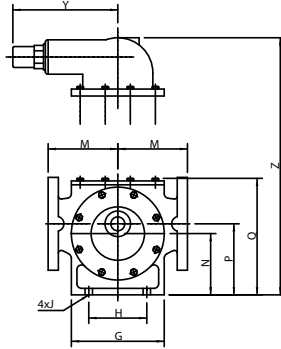

E

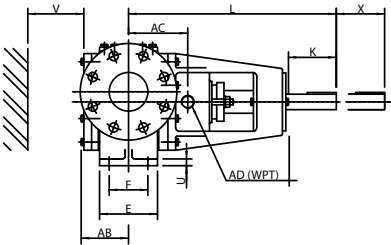

EDK

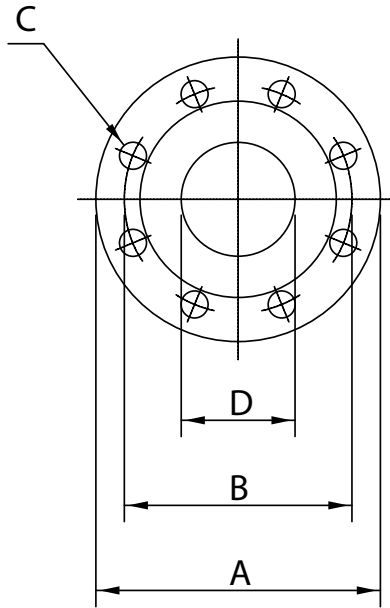
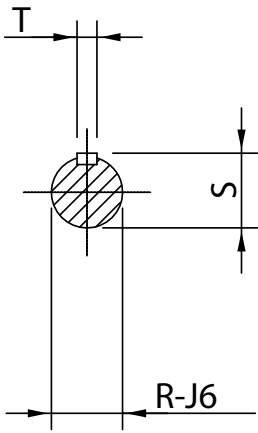
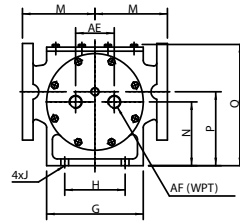

Flanger / Flanges / Flanschen	
ISO 2084/ DIN 2501 / BS 4504 : 1969	
Type Typ	Tryktrin Nomial pressure Nennndruck
26-81	PN 16
101-201	PN 10

Type Typ	Manometertilslutning Pressure gauge connection Manometeranslutninger
26-66	1/4" RG 1/4" WPT 1/4 Rohrgewinde
81-201	3/8" RG 3/8" WPT 3/8" Rohrgewinde

Type Typ	Alle udførelser / All configurations / Alle Ausführungen																				Weight KG										
	A	B*	C*	D	E	F	G	H	J	K	L	M	N	P	Q	R	S	T	U	V	X	Y	Z	AA	AB	AC	AD	AE	AF	Pump	Valve
HD26	115	85	4-Ø14	25	45	28	90	50	Ø7	40	220	83	71	79	126	Ø12	13,5	4	8	50	70	115	176	34	52	42	3/8"	38	3/8"	5,5	2
HD33	140	100	4-Ø18	32	45	28	90	50	Ø7	40	224	83	71	79	126	Ø12	13,5	4	8	60	80	115	172	38	56	45	3/8"	38	3/8"	6	2
HD41	150	110	4-Ø18	40	70	50	120	65	Ø10	48	253	100	100	110	175	Ø16	18	5	10	65	55	115	238	48	58	61	3/8"	50	3/8"	14	2
HD51	165	125	4-Ø19	50	85	60	160	95	Ø12	66	345	125	112	126	213	Ø27	30	8	12	70	70	199	288	61	74	103	1/2"	70	1/2"	35	6
HD66	190	145	4-Ø19	65	95	60	160	95	Ø12	66	350	125	112	126	213	Ø27	30	8	12	80	80	199	288	66	79	114,5	1/2"	70	1/2"	40	6
HD81	210	160	8-Ø19	80	120	80	200	125	Ø15	103	430	150	132	153	257	Ø32	35,5	10	14	100	100	226	363	82	98	127,5	3/4"	80	3/4"	65	10
HD101	229	180	8-Ø19	100	140	110	245	160	Ø15	103	435	180	160	187	307	Ø32	35,5	10	14	115	115	226	413	92	108	127,5	3/4"	90	3/4"	90	10
HD124	229	180	8-Ø19	100	160	120	280	190	Ø19	121	565	200	200	231	367	Ø42	45,5	12	18	140	140	326	525	107	123	150	1"	112	3/4"	138	20
HD126	254	210	8-Ø19	125	160	120	280	190	Ø19	121	565	200	200	231	367	Ø42	45,5	12	18	140	140	326	525	107	123	150	1"	112	3/4"	140	20
HD151	285	240	8-Ø24	150	190	150	330	250	Ø19	121	580	225	225	262	418	Ø42	45,5	12	18	165	165	326	575	125	145	165	1"	130	3/4"	190	20
HD152	285	240	8-Ø24	150	220	160	390	280	Ø24	133	644	275	250	295	480	Ø55	60	16	22	180	180	443	690	144	166	197	1"	140	3/4"	280	60
HD201	340	295	8-Ø24	200	250	200	465	315	Ø24	180	850	300	315	369	582	Ø70	76	20	24	215	215	443	792	168	193	240	1"	200	3/4"	460	60
HD202	343	298,5	8-Ø24	200	280	160	560	400	22	160	965	360	360	420	720	Ø90	95	25	25	250	250	561	1085	187	222	286	1 1/2"	200	1 1/2"	955	145

* Andre dimensioner ved ANSI / Other dimensions by ANSI / Andere Dimensionen bei ANSI

ROTAN® GP

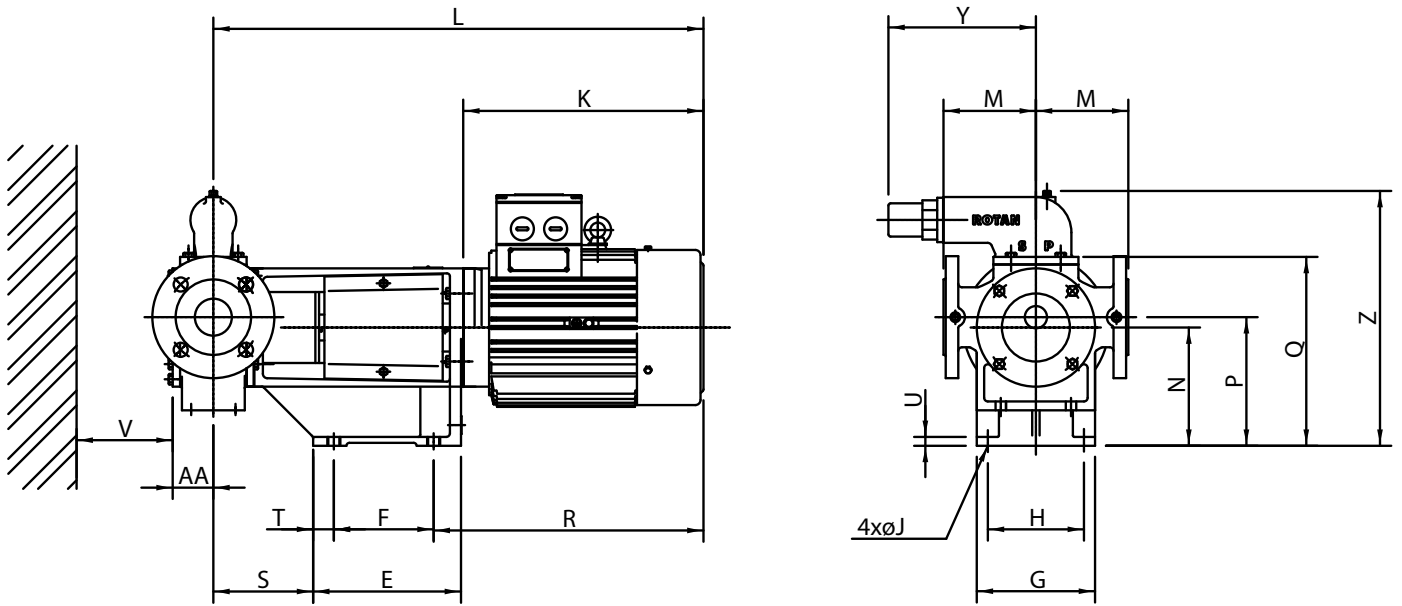

Type Typ	Manometer tilslutning Pressure gauge connectoin Manometeranschlüsse
26-66	1/4" RG 1/4" WPT 1/4" Rohrgewinde
81-101	3/8" RG 3/8" WPT 3/8" Rhorgewinde

IEC / DIN Motorer	
Byggestørrelse / Motor size	Byggeform / Mounting arrangement
80-112	B14
132-160	B5

Flanger / Flanges / Flanschen	
ISO 2084 / DIN 2501 / BS 4504 : 1969	
Type Typ	Tryktrin Nominal pressure Nennndruck
26-81	PN 16
101	PN 10

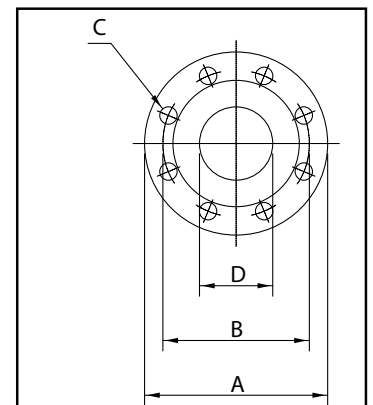

Type	Motor	A	B	C	D	E	F	G	H	J	K	L	M	N	P	Q	R	S	T	U	V	Y	Z	AA	Weight KG	
																									Pump	Valve
GP 26	80	115	85	1" WPT female or 4-Ø14	2"	125	65	120	90	12	255	464	60 or 83	112	120	167	297	82	20	10	50	115	243	34	11	2
	90S					130	70	140	110		265	484	307				87									
	90L					125	65	120	90		290	509	332				87									
GP 33	80	140	100	1 1/4" WPT female or 4-Ø18	32	125	65	120	90	12	255	468	60 or 83	112	120	167	297	86	20	10	60	115	243	38	12	2
	90S					130	70	140	110		265	488	307				91									
	90L					140	80	140	110		290	513	332				91									
	100L					140	80	140	110		325	559	368				91									
	100LX					140	80	140	110		325	559	368				91									
	90S					150	90	140	110		265	519	307				91									
GP 41	90L	150	110	1 1/2" WPT female or 4-Ø18	40	150	90	140	110	15	290	544	90 or 100	132	142	207	332	101	20	10	65	156	270	48	20	2
	100L					160	100	140	110		325	589	368				101									
	100LX					160	100	140	110		325	589	368				101									
	112M2,6,8					160	100	140	110		340	604	383				101									
	112M4					160	100	140	110		340	604	383				101									
	100L					160	100	140	110		325	663	368				101									
GP 51	100LX	165	125	4-Ø19	50	200	135	160	130	15	325	663	125	160	174	261	368	135	25	70	199	199	336	61	50	6
	112M2,6,8					220	140	225	195		340	678	383				135									
	112M4					220	140	225	195		340	678	383				135									
	132S					220	140	225	195		390	748	450				135									
	132SX					220	140	225	195		399	757	459				133									
	132M6,8					220	140	225	195		430	788	490				133									
	132M6,8					220	140	225	195		430	788	490				133									
	132M4, MX6					220	140	225	195		430	788	490				133									
	100L					200	135	160	130		325	668	368				140									
	100LX					200	135	160	130		325	668	368				140									
GP 66	112M2,6,8	190	145	4-Ø19	65	200	135	160	130	15	340	683	125	160	174	261	368	140	25	80	199	199	336	66	55	6
	112M4					220	140	225	195		390	753	450				138									
	132S					220	140	225	195		399	762	459				138									
	132SX					220	140	225	195		430	793	490				138									
	132M6,8					220	140	225	195		430	793	490				138									
	132M4, MX6					220	140	225	195		430	793	490				138									
	160MX8					250	170	250	220		505	898	565				138									
	160M4,6,8					250	170	250	220		505	898	565				138									
	132M6,8					220	140	225	195		390	792	450				177									
	132MX6					220	140	225	195		430	832	490				177									
GP 81	132M6,8	210	160	8-Ø19	80	220	140	225	195	15	430	832	150	200	221	325	490	177	25	16	100	226	431	82	80	10
	160MX8					250	170	250	220		505	937	565				177									
	160M6,8					250	170	250	220		505	937	565				177									
	160L6,8					250	170	250	220		505	937	565				177									
	160L6,8					250	170	250	220		560	992	620				177									
	160L6,8					250	170	250	220		560	992	620				177									
GP 101	132MX6	229	180	8-Ø19	100	220	140	225	195	15	430	837	180	200	227	347	490	182	25	16	115	226	453	92	105	10
	132M6,8					250	170	250	220		505	942	565				182									
	160MX8					250	170	250	220		505	942	565				182									
	160M6,8					250	170	250	220		505	942	565				182									
	160L6,8					250	170	250	220		560	997	620				182									
	180L6,8					250	170	250	220		590	1027	650				182									

ROTAN® PD

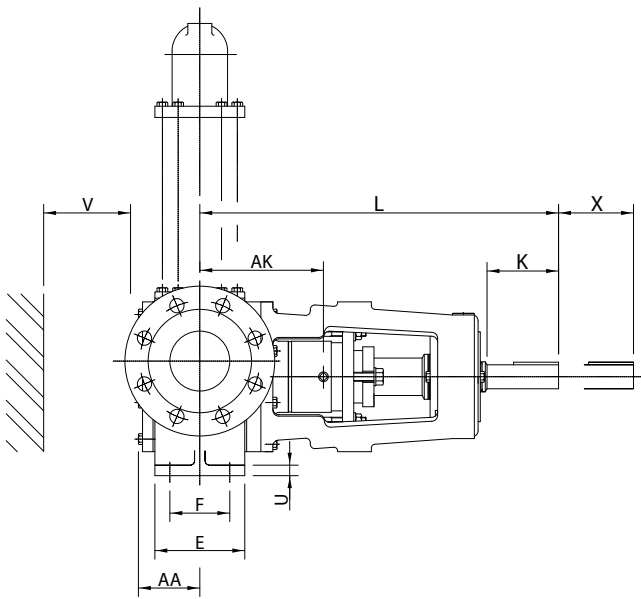

ER

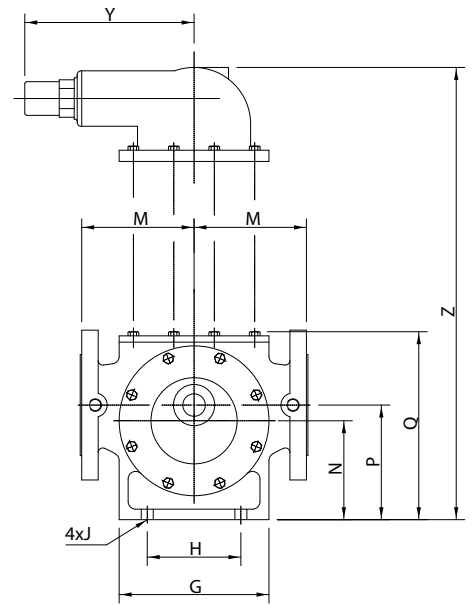

E

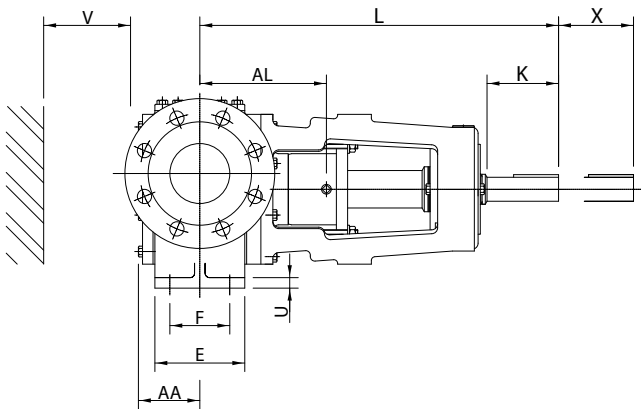

EM

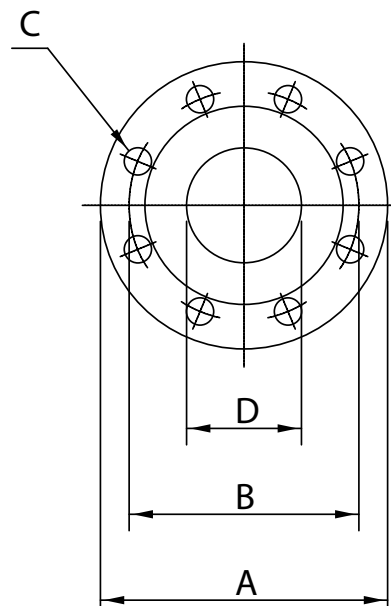
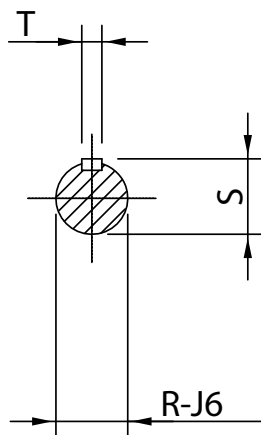
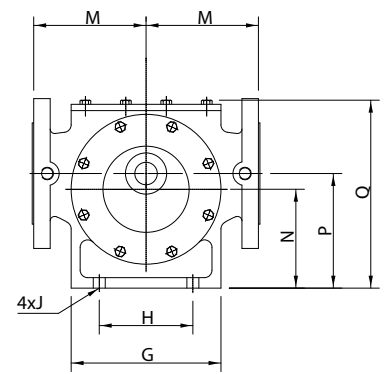

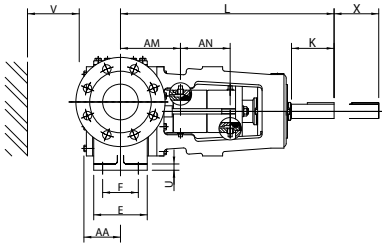

EMM(P)

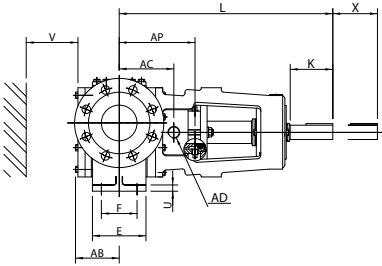
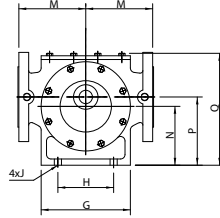

EDK/EMDK

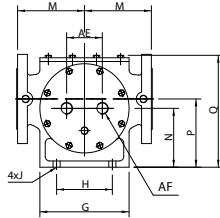

Type Typ	Manometertilslutning Pressure gauge connection Manometeranschlüsse
26-66	1/4" RG 1/4" WPT 1/4" Rohrgewinde
81-201	3/8" RG 3/8" WPT 3/8" Rohrgewinde

Type Typ	Tilslutning for spærrevæske
26-41	1/8" RG 1/8" WPT 1/8" Rohrgewinde
51-151	1/4" RG 1/4" WPT 1/4" Rohrgewinde
201	3/8" RG 3/8" WPT 3/8" Rohrgewinde

Flanger / Flanges / Flanschen				
Type Typ	ISO	DIN	BS	ANSI
26-101	2084-PN16	2501-ND16	4504 1969 PN16	B 16,5 Class 150
126-201	2084-PN10	2501-ND10	4504 1969 PN10	B 16,5 Class 150

Type Typ	Alle udførelser / All configurations / Alle Ausführungen																Weight KG																					
	A	B*	C*	D	E	F	G	H	J	K	L	M	N	P	Q	R	S	T	U	V	X	E		ER		EM		EMM		EDK/EMDK		Pump	Valve					
PD26	115	85	4-Ø14	25	45	28	90	50	Ø7	40	249	83	71	79	126	Ø12	13,5	4	8	50	70	34	76	AK	Y	Z	AL	77	62	57	62	33	1/8"	38	3/8"	76	7	2
PD33	140	100	4-Ø18	32	45	28	90	50	Ø7	40	253	83	71	79	126	Ø12	13,5	4	8	60	80	38	80	AK	Y	Z	AL	81	61	61	62	36	1/8"	38	3/8"	80	10	2
PD41	150	110	4-Ø18	40	70	50	120	65	Ø10	48	293	100	100	110	175	Ø16	18	5	10	65	55	48	89	115	248	94	97	55	58	46	1/4"	50	3/8"	95	18	2		
PD51	165	125	4-Ø19	50	85	60	160	95	Ø12	66	357	125	112	126	213	Ø27	30	8	12	70	70	61	116	199	288	124	94	92	74	55	1/4"	70	1/2"	124	36	6		
PD66	190	145	4-Ø19	65	95	60	160	95	Ø12	66	362	125	112	126	213	Ø27	30	8	12	80	80	66	118	199	288	127	95	91	79	60	1/4"	70	1/2"	119	43	6		
PD81	210	160	8-Ø19	80	120	80	200	125	Ø15	103	488	150	132	153	257	Ø32	35,5	10	14	100	100	82	165	226	363	169	134	111	98	120	1/2"	80	3/4"	170	70	10		
PD101	229	180	8-Ø19	100	140	110	245	160	Ø15	103	493	180	160	187	307	Ø32	35,5	10	14	115	115	92	175	226	413	175	144	116	108	126	1/2"	90	3/4"	170	96	10		
PD126	254	210	8-Ø19	125	160	120	280	190	Ø19	121	585	200	200	231	367	Ø42	45,5	12	18	140	140	107	214	326	525	229	195	127	123	165	1/2"	112	3/4"	215	152	20		
PD151	285	240	8-Ø24	150	190	150	330	250	Ø19	121	600	225	225	262	418	Ø42	45,5	12	18	165	165	125	229	326	575	244	210	127	145	180	1/2"	130	3/4"	230	205	20		
PD201	340	295	8-Ø24	200	250	200	465	315	Ø24	180	850	300	315	369	582	Ø70	76	20	24	215	215	168	305	443	792	327	270	133	193	221	1"	200	3/4"	327	500	60		

* Andre dimensioner ved ANSI / Other dimensions by ANSI / Andere Dimensionen bei ANSI

ROTAN® PD

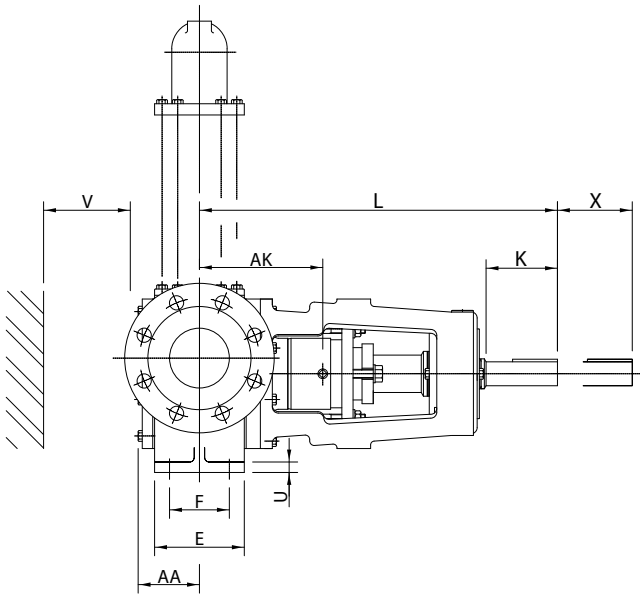

ER

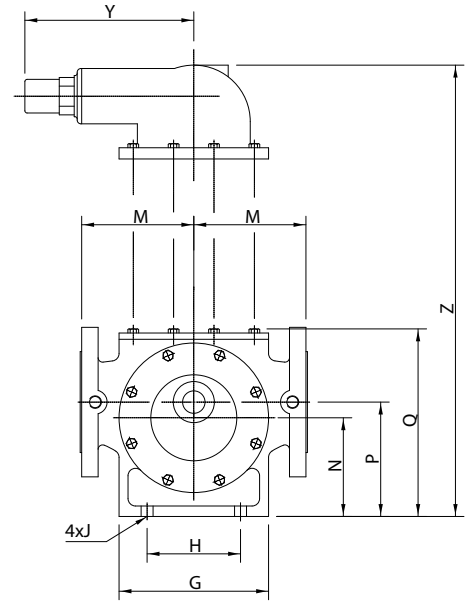

E

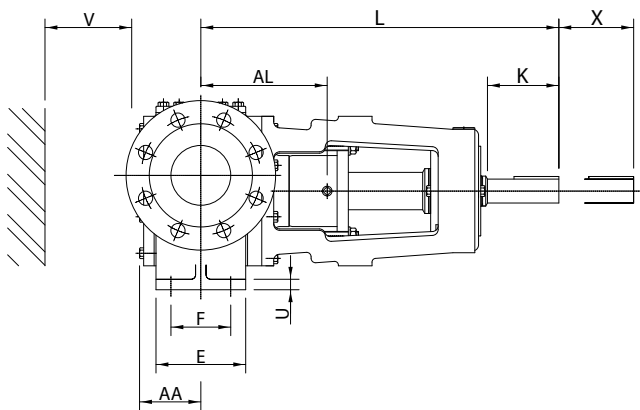

EM

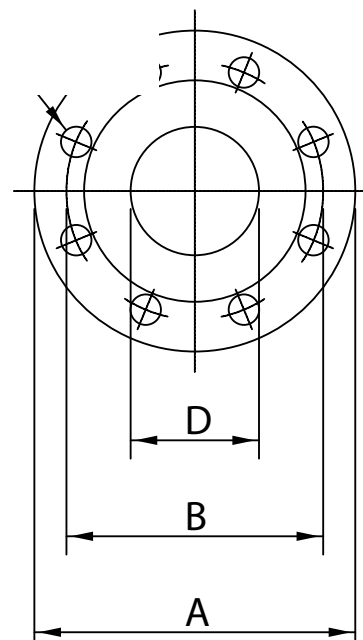
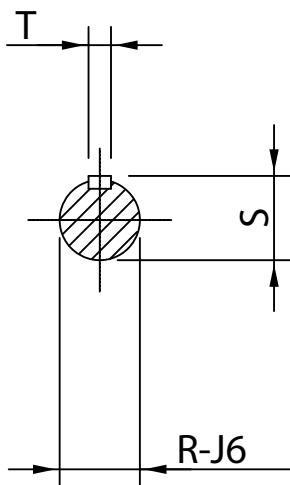
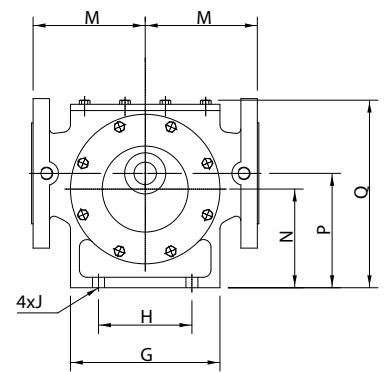

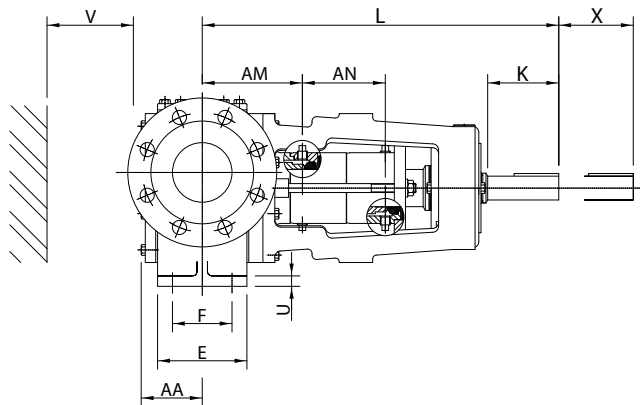

EMM(P)

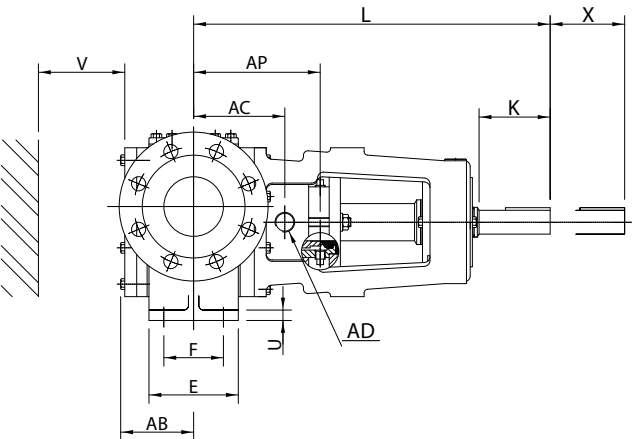
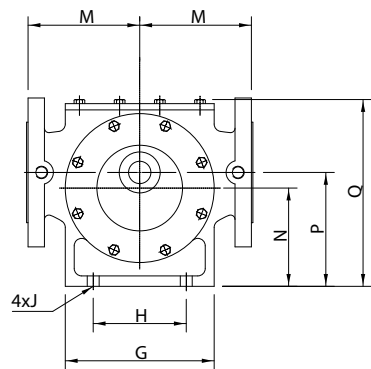

EDK/EMDK

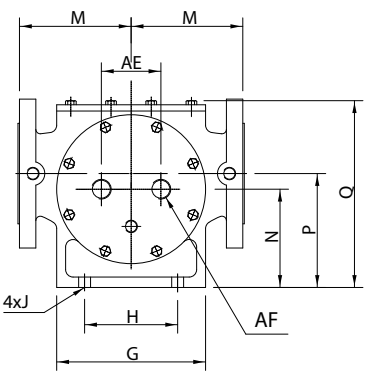

Type Typ	Manometertilslutning Pressure gauge connection Manometeranschlüsse
26-66	1/4" RG 1/4" WPT 1/4" Rohrgewinde
81-201	3/8" RG 3/8" WPT 3/8" Rohrgewinde

Type Typ	Tilslutning for spærrevæske Sealing liquid connection Anschluß für Sperrflüssigkeit
26-41	1/8" RG 1/8" WPT 1/8" Rohrgewinde
51-151	1/4" RG 1/8" WPT 1/8" Rohrgewinde
201	3/8" RG 3/8" WPT 3/8" Rohrgewinde

Flanger / Flanges / Flanschen				
Type Typ	ISO	DIN	BS	ANSI
26-101	2084-PN16	2501-ND16	4504-1969 PN16	B 16,5 Class 150
126-201	2084-PN10	2501-ND10	4504-1969 PN10	B 16,5 Class 150

Type Typ	Alle udførelser / All configurations / Alle Ausführungen																				E		ER		EM		EMM		EDK/EMDK					Weight KG		
	A	B*	C*	D	E	F	G	H	J	K	L	M	N	P	Q	R	S	T	U	V	X	AA	AK	Y	Z	AL	AM	AN	AB	AC	AD	AE	AF	AP	Pump	Valve
CD26	115	85	4-Ø18	25	45	28	90	50	Ø7	40	249	60	71	79	126	Ø12	13,5	4	8	50	70	34	76	115	202	79	57	62	52	33	1/8"	38	3/8"	76	7	2
CD33	140	100	4-Ø18	32	45	28	90	50	Ø7	40	253	60	71	79	126	Ø12	13,5	4	8	60	80	38	80	115	202	81	61	62	56	36	1/8"	38	3/8"	80	10	2
CD41	150	110	4-Ø18	40	70	50	120	65	Ø10	48	293	100	100	110	175	Ø16	18	5	10	65	55	48	89	115	248	94	97	55	58	46	1/4"	50	3/8"	95	18	2
CD51	165	125	4-Ø19	50	85	60	160	95	Ø12	66	357	125	112	126	213	Ø27	30	8	12	70	70	61	116	199	288	124	94	92	74	55	1/4"	70	1/2"	124	36	6
CD66	190	145	4-Ø19	65	95	60	160	95	Ø12	66	362	125	112	126	213	Ø27	30	8	12	80	80	66	118	199	288	127	95	91	79	60	1/4"	70	1/2"	119	43	6
CD81	210	160	8-Ø19	80	120	80	200	125	Ø15	103	488	150	132	153	257	Ø32	35,5	10	14	100	100	82	165	226	363	169	134	111	98	120	1/2"	80	3/4"	170	70	10
CD101	229	180	8-Ø19	100	140	110	245	160	Ø15	103	493	180	160	187	307	Ø32	35,5	10	14	115	115	92	175	226	413	175	144	116	108	126	1/2"	90	3/4"	170	96	10
CD126	254	210	8-Ø19	125	160	120	280	190	Ø19	121	585	200	200	231	367	Ø42	45,5	12	18	140	140	107	214	326	525	229	195	127	123	165	1/2"	112	3/4"	215	152	20
CD151	285	240	8-Ø24	150	190	150	330	250	Ø19	121	600	225	225	262	418	Ø42	45,5	12	18	165	165	125	229	326	575	244	210	127	145	180	1/2"	130	3/4"	230	205	20
CD152	285	240	8-Ø24	150	220	160	390	280	Ø24	133	644	275	250	295	480	Ø55	60	16	22	180	180	144	255	443	690	267	247**	90**	166	200	1"	140	3/4"	283	335	60
CD201	340	295	8-Ø24	200	250	200	465	315	Ø24	180	850	300	315	369	582	Ø70	76	20	24	215	215	168	305	443	792	327	270	133	193	221	1"	200	3/4"	327	500	60

* Andre dimensioner ved ANSI / Other dimensions by ANSI / Andere Dimensionen bei ANSI
 ** Mål for EMMPW / Measures for EMMPW / Dimensionen für EMMPW

ROTAN® ED

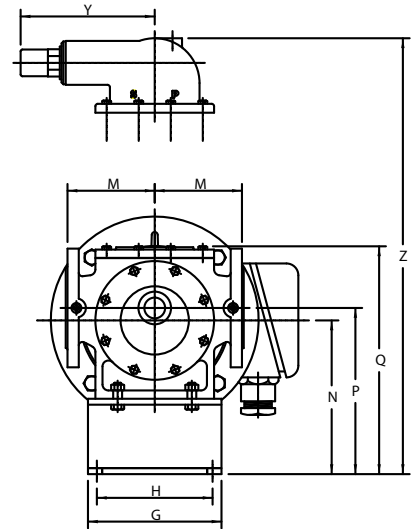
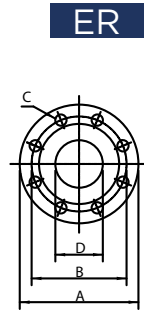
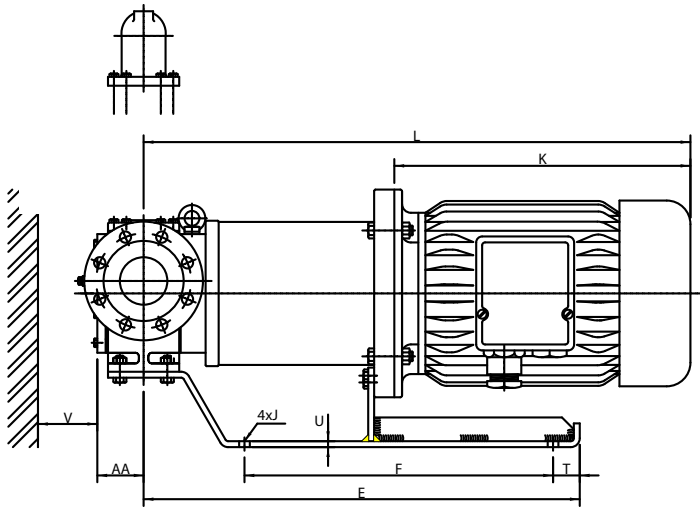

ER

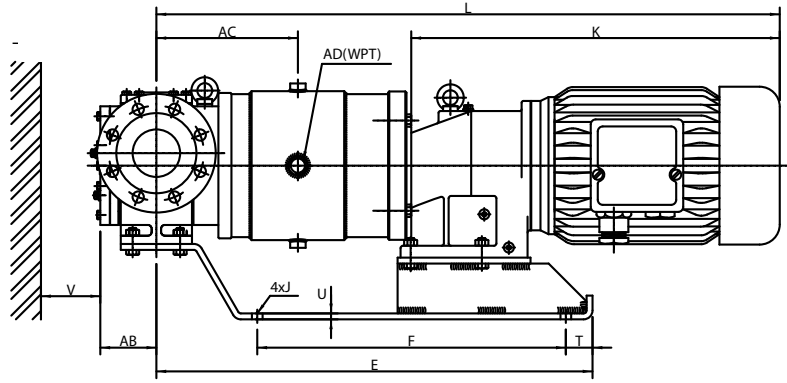

EDK

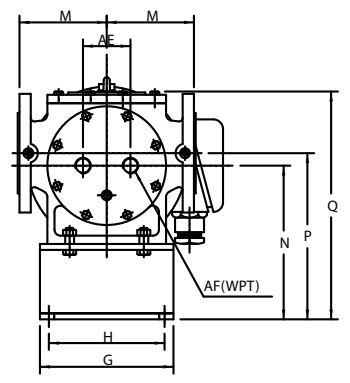

IEC- / DIN Motors	
IEC 100/112 ED26/33/41	Large B14
All other motors	B5

Type Typ	Manometertilslutning Pressure gauge connection Manometeranschlüsse
26-66	1/4" RG 1/4" WPT 1/4" Rohrgewinde
81-201	3/8" RG 3/8" WPT 3/8" Rohrgewinde

Flanger / Flanges / Flanschen				
Type Typ	ISO	DIN	BS	ANSI
26-101	2084-PN16	2501-ND16	4504-1969 PN16	B 16,5 Class 150
126-201	2084-PN10	2501-ND10	4504-1969 PN10	B 16,5 Class 150

Type	Motor Gear	Alle udførelser / All configurations / Alle Ausführungen														Weight KG																
		A	B**	C	D	E	F	G	H	J	K*	L*	M	N	P	Q	T	U	V	Y	Z	AA	AB	AC	AD	AE	AF	pump	valve			
ED 26	IEC 80/90	1" WPT female or				434					209..303	459..553	60	152	160	209				50	115	254 284	35	43	162		38	3/8"	3/8"	29		
	IEC 100/112	115	85	4-Ø14	25						272..340	522..590																				83
	Gearmotor										358..512	619..775																				
ED 33	IEC 80/90	1 1/4" WPT female or				438	300	140	110	Ø14	209..303	463..557	60	170	180	244				65	156	309	45	56	174		50	40				
	IEC 100/112	140	100	4-Ø18	32						272..340	526..594																			83	
	Gearmotor										358..512	623..779																				
ED 41	IEC 90	1 1/2" WPT female or				446					303	565	90	259	280	384				70	199	413	56	70	186		70	1/2"	90			
	IEC 100/112	150	110	4-Ø18	40						272..340	534..602																			100	
	Gearmotor										403..552	680..829																				
ED 51	IEC 100/112	2" WPT female or				595	400	160	130		272..340	513..681	125	236	250	335				80	226	490	78	95	239		80	3/4"	180			
	IEC 132	165	125	4-Ø19	50						430	771																			150	
	IEC 160										560	909																				
ED 66	IEC 100/112	2 1/2" WPT female or				600				Ø18	468..722	812..1071	150	259	280	384				100	226	526	88	105	244		90	3/4"	200			
	IEC 132	190	145	4-Ø19	65						430	776																			180	
	IEC 160										560	914																				
ED 81	IEC 160/180	210	160	8-Ø19	80	735	520	225	195		560..630	872..1033	200	273	300	420			115	326	607	101	118	339		112	3/4"	350				
	IEC 132	229	180	8-Ø19	100	740					567..855	997..1303																		225		
	Gearmotor					567..855					997..1303																					
ED 101	IEC 160/180	229	180	8-Ø19	100	740	300	260		Ø22	660	1164	200	278..318	315..355	470..510			140	326	607	101	118	339		112	3/4"	350				
	IEC 132	229	180	8-Ø19	100	740					660	1179																		225		
	Gearmotor					567..855					997..1303																					
ED 126	IEC 200	254	210	8-Ø19	125	851	300	260		Ø22	660	1164	200	278..318	315..355	470..510			140	326	607	101	118	339		112	3/4"	350				
	IEC 200	285	240	8-Ø24	150	866					660	1179																		225		
	Gearmotor					640..855					1216..1431																					
ED 151	Gearmotor	285	240	8-Ø24	150	866	350	310			640..855	1216..1431	225	278..318	315..355	470..510			165	628..668	119	140	358		130	400						

* Præcise dimensioner på forespørgsel / Precise measures on request. / Genaue Dimensionen an anfrage ** Andre dimensioner ved ANSI / Other dimensions by ANSI / Andre Dimensionen Bei ANS