

ROTAN® HD202



DESMI ROTAN® Pumps are used in many manufacturing industries and processes for the transportation of thin and thick liquids from Diesel Fuel to Chocolate. For almost a century we have been manufacturing and supplying internal gear pumps for industry.

This gives DESMI ROTAN® the experience required to be key partner in understanding your process and key supplier to your business.

Top Design + Top Selection = Top Reliability

Features and Benefits, upgraded design:

Large inlet and outlet ports (DN200/8")

- Rotors and gears with optimized tooth design
- New rotor design with 11 instead of 9 teeth
- Better selfpriming
- Large shaft diameters and double angular contact bearings for increased max pressure
- Feet under the pump casing giving a full front and back pull out design
- Relief valve with top pull out function
- Professional application support and engineering

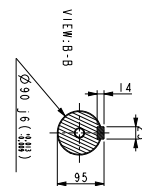
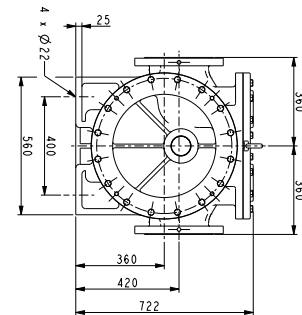
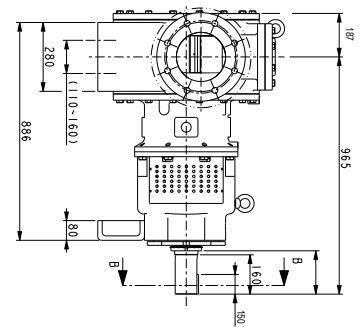

Components	Standard	Optional
Casing	Ductile Cast Iron	
Covers	Ductile Cast Iron	
Rotor/idler	Ductile Cast Iron	
Bracket	Ductile Cast Iron	
Shaft	Carbon Steel	
Idler pin	Hardened Steel	Steel
Idler bushing	Bronze	Cast iron/Carbon/T.C
Main bearing	Bronze	Cast iron/Carbon/T.C

Technical data:	
Max Capacity	250m ³ /h / 1100 gpm
Max Pressure	14 bar / 203 psi
Material	Ductile Cast Iron, GGG40 (upgraded material from GG25)
Dimensions:	identical to RT200 (only longer)
Max speed	300rpm
Max Viscosity	250.000cSt
Max temp	250°C / 480°F
Displacement	14 l/rev / 3.7 gal./rev.