

DESMI self-priming centrifugal pump

Modular S-N Monobloc

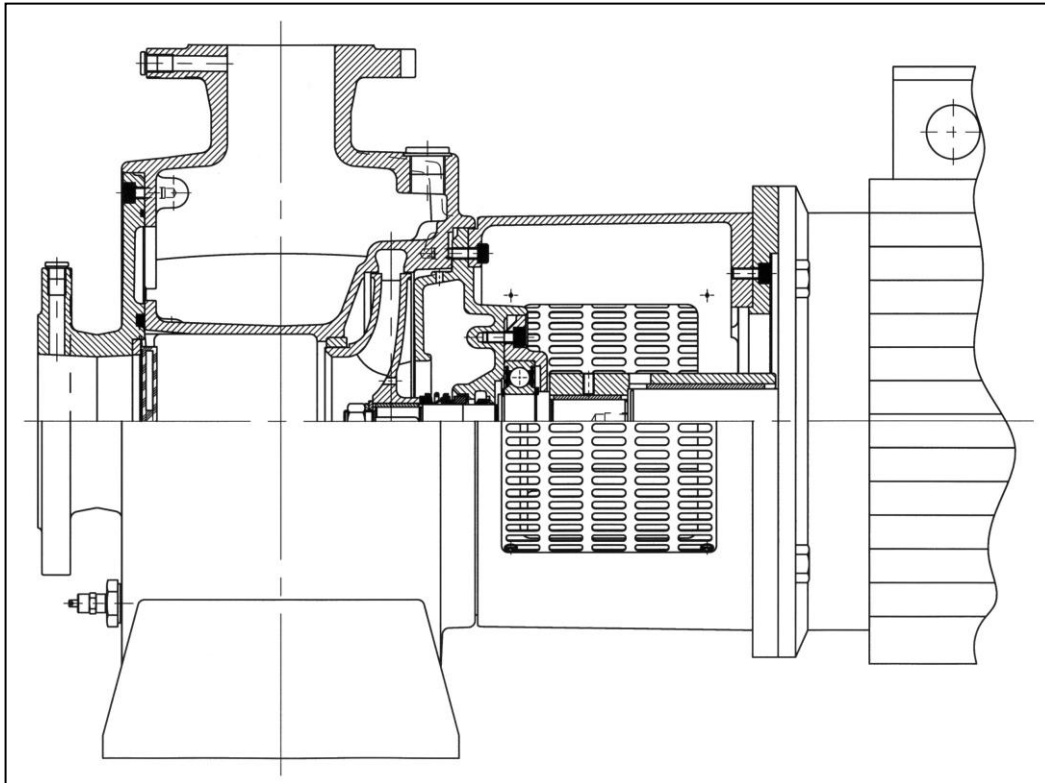

DESMI PUMPING TECHNOLOGY A/S
Tagholm 1 – DK-9400 Nørresundby – Denmark

Tel.: +45 96 32 81 11
Fax: +45 98 17 54 99
E-mail: desmi@desmi.com
Internet: www.desmi.com

Manual: T1441	Language: English	Revision: J (11/09)
------------------	----------------------	------------------------

Special pump No.....



Contents

1. PRODUCT DESCRIPTION	4
1.1 DELIVERY.....	4
2. TECHNICAL DATA	4
2.1 NAME PLATE	5
2.2 EXPLANATION OF THE TYPE NUMBER	5
2.3 TECHNICAL DESCRIPTION	6
3. INSTALLATION	7
3.1 MOUNTING/FASTENING	7
4. TRANSPORT/STORAGE	8
5. DISMANTLING	9
5.1 ACCESS TO IMPELLER	9
5.2 DISMANTLING SHAFT SEAL	9
5.3 DISMANTLING SEAT	10
5.4 DISMANTLING BEARING	10
5.5 INSPECTION	10
5.6 DISMANTLING COUPLING	10
6. ASSEMBLING	10
6.1 FITTING SEALING RING IN PUMP CASING.....	10
6.2 FITTING BEARING	10
6.3 FITTING WATER DEFLECTOR	10
6.4 FITTING SHAFT SEAL.....	11
6.5 FITTING IMPELLER.....	11
6.6 FITTING GUIDE RING AND GUIDE VANE PIECE (ONLY S32-25-110N).....	11
6.7 FITTING BEARING COVER AND SHAFT SEAL COVER	12
6.8 FITTING COUPLING	12
6.9 SHAFT.....	12
7. FROST PROTECTION	12
8. DISMANTLING	13
9. START-UP	13
9.1 STARTING	13
10. SYSTEM BALANCING	14
11. INSPECTION AND MAINTENANCE	16
11.1 DRAINING THE PUMP.....	16
11.2 BEARING	16
12. REPAIRS	16
12.1 ORDERING SPARE PARTS	16
13. OPERATING DATA	16
15. INFORMATION RELEVANT FOR DISASSEMBLY OR DISPOSAL AT END-OF-LIFE	19
16. ASSEMBLY DRAWINGS	19
16.1 ASSEMBLY DRAWING FOR PUMPS BIGGER THAN S32-25-110 AND S50-32-135N	19
16.2 ASSEMBLY DRAWING FOR S32-25-110 AND S50-32-135N	20
17. SPARE PARTS LISTS	20

17.1 SPARE PARTS LIST FOR PUMPS BIGGER THAN S32-25-110 AND S50-32-135N.....	20
17.2 SPARE PARTS LIST FOR S32-25-110 AND S50-32-135N.....	21
18. DIMENSIONAL SKETCH.....	21

1. PRODUCT DESCRIPTION

These operation and maintenance instructions apply to the DESMI Modular S-N Monobloc pump series. The pumps are available in sizes ranging from 25 to 100 mm on the pressure flange. The suction flange is bigger than the pressure flange.

DESMI S-N is a single-stage self-priming centrifugal pump with stainless steel shaft, mechanical shaft seal, and closed impeller.

The pump is suitable for the pumping of clean and polluted liquids with temperatures between 0 and 80°C. With special shaft seal up to 140°C. Max. number of revolutions: 3600 RPM.

The pump has horizontal inlet on the centre line and vertical outlet at the top.

The back of the impeller is equipped with relief blades to reduce the load on the bearings.

Relief holes in the impeller ensure circulation of liquid for the shaft seal and prevent overheating of the shaft seal during normal operation.

The pump is particularly suitable for the pumping of water in connection with f.inst. cooling of diesel engines, as bilge pumps, ballast pumps, pumps for irrigation, washing plants, air conditioning, cooling systems, and sanitary systems, etc. Furthermore, in the majority of cases where the transport of liquid is required within industry.

1.1 DELIVERY

- Check on delivery that the shipment is complete and undamaged.
- Defects and damages, if any, to be reported to the carrier and the supplier immediately in order that a claim can be advanced.

2. TECHNICAL DATA

The pumps are manufactured in various material combinations which appear from the type number on the name plate. See below.

2.1 NAME PLATE

Manufacturer:

DESMI

DK-9400 Nørresundby

Phone +45 96328111

Fax +45 98175499

e-mail: desmi@desmi.com

<http://www.desmi.com>

TYPE: Pump type number

CODE NO.: Pump item No.

PUMP NO.: Pump No.

IMP.: Impeller diameter

WEEK/YEAR: Production week and year

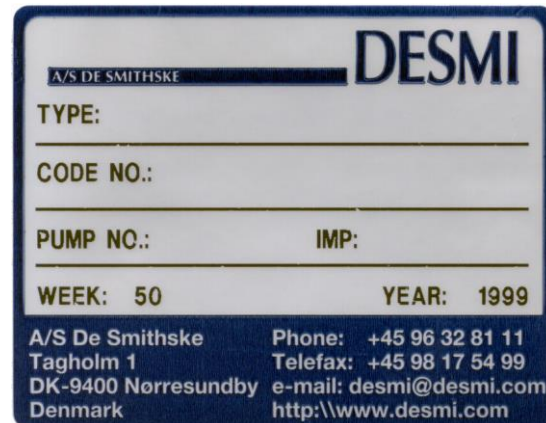

2.2 EXPLANATION OF THE TYPE NUMBER

All the S-N pumps are provided with a name plate. The type number indicated on the name plate is built up as follows:

SXXX-YYY-ZZZN-MR

XX.YYY, ZZZ: Pump size where

XXX = Suction branch diameter, YYY = Pressure branch diameter,

ZZZ = Standard impeller diameter.

M: The material combination of the pump.

R: The assembly combination of the pump.

M may be the following:

A : Standard. Casing: GG20. Impeller: AIBz.

C : All cast iron.

D : Casing: Rg5, Impeller: AIBz.

E : Casing and shaft seal cover: NiAlBz and bronze alloy. Impeller and sealing rings: NiAlBz

U : Nonmagnetic

The pumps can be delivered in other material combinations which are agreed with the supplier.

R may be the following:

01 : With electromagnetic coupling.

02 : Monobloc, flange-mounted with electric motor.

03 : With hydraulic motor.

04 : V-belt pulley and disengaging clutch.

07 : On a base plate with petrol or diesel engine, or with electric motor.

08 : Mounted on a trolley with petrol or diesel engine, or with electric motor.

- 09 : With bare shaft end.
- 10 : Special-tailored according to task.

Any use of the pump is to be evaluated on the basis of the materials used in the pump. In case of doubt, contact the supplier.

Pumps in material combinations A and C are primarily used for fresh water.
Pumps in material combination D are primarily used for sea water.

2.3 TECHNICAL DESCRIPTION

The noise level indicated is the airborne noise including the motor. The noise depends on the motor type supplied, as the noise from the pump can be calculated as the noise level of the motor + 2dB(A).

The capacity of the pump appears from the name plate on the pump. If the pump has been delivered without motor, the pump capacity is to be indicated on the plate when mounting the motor.

The permissible loads on the flanges appear from the following table:

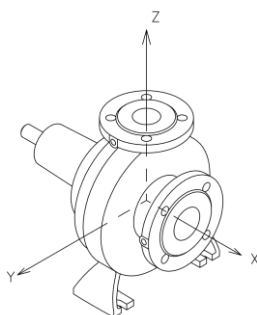

Pump	Fv N	Fh N	$\Sigma F N$	$\Sigma Mt Nm$
S32-25-110	1250	950	1550	200
S50-32-135N	1250	950	1550	200
S70-50-175N	1350	1000	1700	200
S70-50-220N	1350	1000	1700	200
S70-50-275N	1350	1000	1700	250
S80-70-175N	1450	1050	1800	270
S80-70-220N	1450	1050	1800	270
S80-70-275N	1450	1050	1800	270
S100-80-175N	1800	1250	2200	470
S100-80-220N	1800	1250	2200	470
S100-80-275N	1800	1250	2200	470

S125-80-220N	3200	1900	3750	950
S125-80-275N	3300	2000	3850	1020
S125-100-220N	3300	2000	3850	1020

In connection with the permissible loads on the flanges the following is to be observed:

$$\frac{2}{3} F_{zout} + F_{zin} \leq F_v$$

$$\sqrt{F_{xin}^2 + F_{yin}^2} + \sqrt{F_{xout}^2 + F_{yout}^2} \leq F_h$$

$$\sqrt{M_{xin}^2 + M_{yin}^2 + M_{zin}^2} + \sqrt{M_{xout}^2 + M_{yout}^2 + M_{zout}^2} \leq M_t$$

$$\left(\frac{\sum F_{calc}}{\sum F} \right)^2 + \left(\frac{\sum M_{calc}}{\sum M_t} \right)^2 < 2$$

where indices "in" is suction branch, "out" is pressure branch, and "calc" are the values calculated by the user.

3 . INSTALLATION

3.1 MOUNTING/FASTENING

The pump should be mounted and fastened on a solid base plate with a flat and horizontal surface to avoid distortion.

The pump must be installed with horizontal shaft and the pump casing discharge side vertically upwards.



Notes: Misalignment of the pump/motor could cause damage to pump, motor and/or pump ball bearing(s) and the rigid coupling between pump and motor. It is most likely required to use shim(s) below motor feet for preventing misalignment of pump and motor when the unit is mounted onto a concrete plinth or base plate.

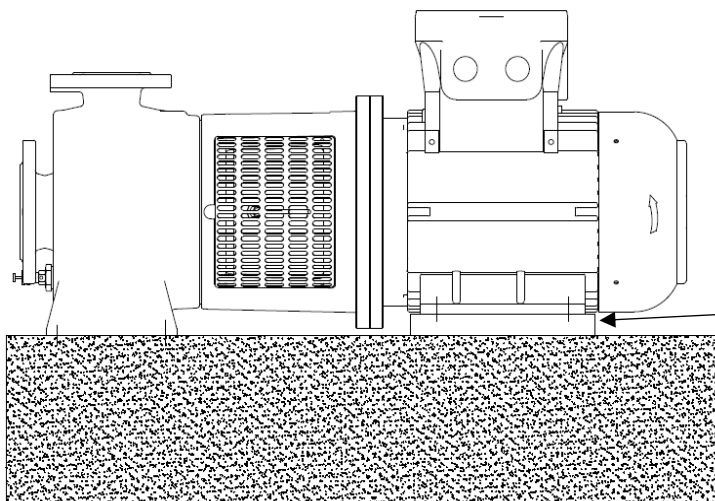

Use shim(s) between motor foot and concrete plinth or base plate to avoid tension in motor foot

Mounting steps as below:

- I. Tighten the 4 screws retaining the pump feet diagonally.
- II. Check if any of the motor feet are lifted up? Using shim(s) under some of the motor feet are required in the position where it is lifted up for avoiding deformation/twisting of the pump's motor bracket. Then tighten the 4 screws retaining the motor feet.
- III. Open coupling guard to check the pump shaft can be rotated freely by hand.

Be careful when fitting the suction line to the pump so that it is absolutely tight, as even small leakages may impede the priming. When pumping polluted liquids a strainer is necessary. The strainer must be equipped with a sieve, the passage area of which is to be 3 x the area of the suction pipe. The mesh size is to be 1-3 mm smaller than the impeller gap of the pump in question.

The max. permissible loads on the flanges stated in paragraph 2.3 are to be observed.



At installations pumping hot or very cold liquids, the operator must be aware that it is dangerous to touch the pump surface, and, consequently, he must take the necessary safety measures.

When connecting the pump and a prime mover the power transmission is to be equipped with a guard in accordance with the provisions of the COUNCIL DIRECTIVE of June 14, 1989, on the safety of machines.

3.2 WIRING



Wiring to be carried out by authorized skilled workmen according to the rules and regulations in force.

4. TRANSPORT/STORAGE

The weights of the pumps are stated in the following table, and the pumps are to be lifted as shown below.

Pump	Weight kg	Pump	Weight kg
S32-25-110	24.5	S80-70-275N	91.0
S50-32-135N	25	S100-80-175N	76.0
S70-50-175N	45.0	S100-80-220N	97.0
S70-50-220N	61.0	S100-80-275N	112.0
S70-50-275N	75.0	S125-80-220N	122.0
S80-70-175N	56.0	S125-80-275N	129.0
S80-70-220N	62.0	S125-100-220N	147.0

The pump is to be stored in a dry area.

Before shipment the pump is to be fastened securely on pallets or the like.
The pump is to be lifted in the following way:

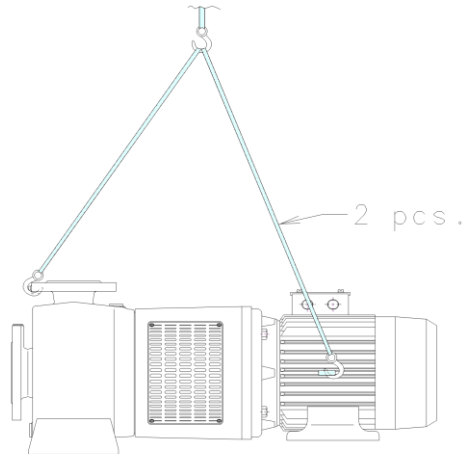

The lifting straps must not bear against sharp edges and corners.

5. DISMANTLING

5.1 ACCESS TO IMPELLER

Remove guards (28). Remove Allen screws (22), which hold the shaft seal cover and the monobloc bracket to the pump casing. The pump casing can now be pulled away allowing inspection of the impeller.

Only S32-25-110N and S50-32-135N:

Remove Allen screw (22) which holds the bearing housing and the monobloc bracket to the pump casing and pull the bearing housing with impeller and guide vane piece out of the pump casing.

Then remove Allen screw (29) (only S32-25-110N), and guide vane piece and guide ring can be dismantled from the bearing housing.

5.2 DISMANTLING SHAFT SEAL

Pull the shaft seal cover free of the monobloc bracket, by which the coupling is pulled off the motor shaft. Remove nut (6). Pull off the impeller and remove sunk key (9). Remove Allen screws (16), which hold the bearing cover to the shaft seal cover, pull shaft seal cover and bearing cover apart, by which shaft seal and water deflector are pulled off the shaft.

Only S32-25-110N and S50-32-135N:

Unscrew impeller. Dismantle the oil seal ring (31) by puncturing the front to permit the oil seal ring to be pulled out with a hook. The oil seal ring cannot be used again. Dismantle the ring lock (30), and the shaft with bearings can be pulled out of the bearing housing. At the same time, the shaft seal and the water deflector are pulled off the shaft.

5.3 DISMANTLING SEAT

Press out the seat from behind the shaft seal cover (the bearing housing in S32-25-110N and S50-32-135N).

5.4 DISMANTLING BEARING

Before dismantling bearing remove ring lock (12). Then pull the shaft/coupling out from the bearing cover and press the bearing out of the bearing cover.

5.5 INSPECTION

When the pump has been dismantled, check the following parts for wear and damage:

- Sealing ring/impeller : Max. clearance 0.4-0.5 mm measured in radius.
(There is no sealing ring in S32-25-110N and S50-32-135N)
- Shaft seal/shaft seal cover : Check the seat for flatness and cracks.
Check the rubber parts for elasticity.
- Bearing : Replace in case of wear and noise.
- Non-return flap : Check for cracks and hardness

5.6 DISMANTLING COUPLING

It is not necessary to remove the coupling from the pump shaft during normal maintenance. Otherwise dismantle the coupling by removing the pointed screw and pulling off the coupling. If the coupling is dismantled on the assembled pump, take care that the bearing is not damaged by pulling too hard in the coupling. If the coupling is removed after dismantling the pump, fix the shaft at the thread on the opposite shaft end while the coupling is pulled off.

6. ASSEMBLING

6.1 FITTING SEALING RING IN PUMP CASING

When fitted, the sealing ring is to bear against the shoulder of the pump casing.

6.2 FITTING BEARING

Place the support disc (14) in the bearing cover and press the bearing into place in the bearing cover. Lead the shaft through the bearing cover, support disc and bearing, and press the bearing into place up against the support disc. Fit ring lock (12). (Fit ring lock (30) and a new oil seal ring (31) in S32-25-110N or S50-32-135N).

6.3 FITTING WATER DEFLECTOR

Tighten the bearing cover to the shaft seal cover. Lead the water deflector over the shaft until it touches the shaft seal cover and then further 1-1.5 mm into the shaft seal cover (the bearing housing in S32-25-110N or S50-32-135N).

6.4 FITTING SHAFT SEAL

Before fitting the seat, clean the recess in the shaft seal cover (bearing housing in S32-25-110N and S50-32-135N). When fitting the seat, remove the protective coating, if any, without scratching the lapped surface. Dip the outer rubber ring of the seat into soapy water. Now press the seat into place with the fingers and check that all parts are correctly imbedded. If it is necessary to use tools for assembling, then protect the sliding surface of the seat to prevent it from being scratched or cut. Lubricate the inner diameter of the slide ring rubber bellows with soapy water and push it over the shaft. The use of a fitting bush as shown on the below assembly drawing is recommended to avoid that the rubber bellows is cut. Push the slide ring over the shaft with the hand. If the rubber bellows is tight, use a fitting tool and take care that the slide ring is not damaged.

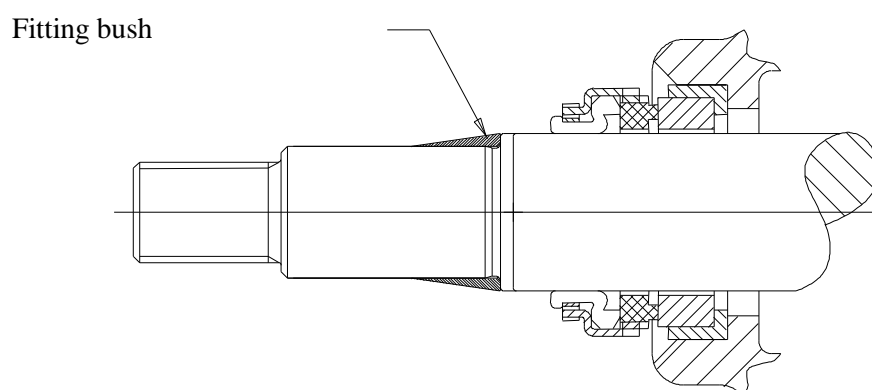

If the carbon ring is not fixed, it is important to check that it is fitted correctly, i.e. the chamfered/lapped side is to face the seat. The carbon ring can be held by a little grease. When using oil on the shaft, the bellows will settle and seat in about 15 minutes, and until then tightness should not be expected. After start, check by viewing the leak hole that there are no leaks.

6.5 FITTING IMPELLER

Fit the sunk key in the shaft and lead the impeller towards the shoulder of the shaft. Take care that the ring at the end of the shaft seal spring locates in the recess of the impeller. Secure the impeller with a washer and a nut.

Only S32-25-110N and S50-32-135N:

Apply Loctite 243 or similar to the thread on the shaft. Screw the impeller towards the shoulder of the shaft. Take care that the ring at the end of the shaft seal spring locates in the recess of the impeller. Tighten the impeller with 60 Nm torque.

6.6 FITTING GUIDE RING AND GUIDE VANE PIECE (ONLY S32-25-110N)

Place the guide ring (35) in the recess of the bearing housing. Fit and fasten the guide vane piece on the guide ring. Note that the flat part of the inlet neck of the guide vane piece is to face upwards, i.e. opposite of the drain passage for the shaft seal in the bearing housing. If the shaft cannot rotate freely, dismantle the guide vane piece again, and place a shim (34) between bearing housing and guide ring.

6.7 FITTING BEARING COVER AND SHAFT SEAL COVER

Place the gasket between pump casing and shaft seal cover on the shaft seal cover where it can be held with a little grease. Fit and fasten bearing cover and shaft seal cover. Check that the drain passage for the shaft seal faces downwards.

S32-25-110N:

Place the gasket (21) between pump casing and bearing housing on the bearing housing. Check that the non-return flap is placed correctly in the pump casing. Lead the bearing housing into place and fasten. Note that the drain passage for the shaft seal faces downwards.

S50-32-135N:

Place the gasket (21) between pump casing and bearing housing on the bearing housing. Lead the bearing housing into place and fasten. Note that the drain passage for the shaft seal faces downwards. If the shaft cannot rotate freely, dismantle the bearing housing again, and place an extra gasket (21) between bearing housing and pump casing.

6.8 FITTING COUPLING

Fit sunk key . If the coupling is fitted on the assembled pump, take care that you do not damage the bearing by pressing the coupling too hard. The coupling might be heated to facilitate the fitting. If the coupling is fitted before assembling the pump, the shaft is supported at the opposite shaft end while the coupling is pressed into place. When the coupling bears against the shoulder of the pump shaft, fit the pointed screw.

6.9 SHAFT

When the pump has been assembled, check that the shaft rotates freely.

7. FROST PROTECTION

Pumps which are not in operation during frost periods are to be drained to avoid frost damage. Remove the plug in the inlet cover to empty the pump. Alternatively, it is possible to use anti-freeze liquids in normal constructions.

8. DISMANTLING



Before dismantling the pump make sure that it has stopped. Empty the pump of liquid before it is dismantled from the piping system. If the pump has been pumping dangerous liquids you are to be aware of this and take the necessary safety measures.

If the pump has been pumping hot liquids, take great care that it is drained before it is removed from the piping system. If cold or very hot liquids have been pumped, the operator must be aware that it is dangerous to touch the pump surface and he must, consequently, take the necessary safety measures.

9. START-UP

A self-priming centrifugal pump will not function until it has been filled with liquid.



The liquid also serves as coolant for the shaft seal. In order to protect the shaft seal the pump must not run dry.

WARNING

For safety reasons the pump is only allowed to operate against closed discharge valve for a short time (max. 5 minutes and at a max. temperature of 80°C for standard pumps). Otherwise there is a risk of damage to the pump and, at worst, of a steam explosion. If the pump is not monitored, the installation of a safety device is recommended.

To protect the pump against unintentional operation it is equipped with a relief valve which opens at a preset pressure.

Be careful: When the valve opens, the escaping liquid will be hot.

The relief valve must in **no** circumstances be removed or re-adjusted !

As regards maintenance of the relief valve - see paragraph 11.

9.1 STARTING

Before starting the pump check that:

- the shaft rotates freely without jarring sounds.
- the pump casing and the suction line are filled with liquid.

Start the pump for a moment to check the direction of rotation. If the direction is correct (i.e. in the direction of the arrow) the pump may be started.

10. SYSTEM BALANCING

It is often difficult to calculate a manometric delivery head in advance. It is, however, decisively important to the quantity of liquid delivered. A considerably smaller delivery head than expected will increase the quantity of liquid delivered, causing increased power consumption and perhaps cavitation in pump and piping. In the pump the impeller may show signs of heavy erosion caused by cavitation (corrosion) which may at times render an impeller unfit for use in a very short time. Not unusually do similar erosions occur in pipe bends and valves elsewhere in the piping system.

Therefore, after start-up, it is necessary to check either the quantity of liquid delivered or the power consumption of the pump e.g. by measuring the current intensity of the connected motor. Together with a reading of the differential pressure the quantity of water delivered can be determined against the characteristics of the pump.

Should the pump not function as intended, please proceed according to the fault-finding list. Bear in mind, though, that the pump was carefully checked and tested at the factory and that the majority of faults stem from the piping system.

FAULT	CAUSE	REMEDY
The pump does not prime	<ol style="list-style-type: none"> 1. The pump is not filled with liquid 2. Leaking non-return valve in pump 3. Wrong direction of rotation 4. Air is drawn in because of too little liquid or leaking suction line 5. Liquid lock in outlet line 6. Temperature of liquid too high 7. Air cannot escape on pressure side 	<p>Fill pump casing with liquid</p> <p>Remove foreign body in valve/Remove any coating on mating faces</p> <p>Change direction of rotation</p> <p>Lower suction pipe/ Tighten suction line</p> <p>Change the pressure line so that the air can pass out freely</p> <p>Replace liquid in pump casing/Wrong dimensioning/Contact DESMI</p> <p>Ventilate the system</p>
The pump has no or too low capacity	<ol style="list-style-type: none"> 1. Wrong direction of rotation 2. Piping system choked 3. The pump is choked 4. Suction line leaks Pump takes air 5. Suction lift too high 6. Pump and piping system wrongly dimensioned 	<p>Change direction of rotation to clockwise when viewed from shaft end (the direction of the arrow)</p> <p>Clean or replace</p> <p>Clean the pump</p> <p>Find the leakage/repair the fault, non-return valve not submerged</p> <p>Check data sheet Q/H curve and NPSH or contact DESMI</p> <p>As 5</p>
The pump uses too much power	<ol style="list-style-type: none"> 1. Counter-pressure too low 2. The liquid is heavier than water 3. Foreign body in pump 4. Electric motor is running on 2 phases 	<p>Insert orifice plate or check valve/Contact DESMI</p> <p>Contact DESMI</p> <p>Dismantle the pump, remove the cause</p> <p>Check fuses, cable connection, and cable</p>
The pump makes noise	<ol style="list-style-type: none"> 1. Cavitation in pump 	<p>Suction lift too high/ Suction line wrongly dimensioned/Liquid temperature too high</p>

11. INSPECTION AND MAINTENANCE

Inspect the shaft seal for leaks at regular intervals.

Activate the relief valve at regular intervals in order to check the function. If the valve is choked, replace or clean it, if possible.

- Before inspection of a pump without guard check that the pump cannot be started unintentionally.
- The system is to be without pressure and drained of liquid.
- The repairman must be familiar with the type of liquid which has been pumped as well as the safety measures he is to take when handling the liquid.

11.1 DRAINING THE PUMP

When the piping system has been drained, note that there is still liquid in the pump. Remove the liquid by dismantling the pipe plug (3) in the inlet cover of the pump.

11.2 BEARING

The pump is equipped with a ball bearing which is dimensioned for a nominal life of 25,000 working hours. The bearing is lubricated for life and requires no attention but is to be replaced in case of noise or bearing wear.

12. REPAIRS

12.1 ORDERING SPARE PARTS

When ordering spare parts please always state pump type and serial No. (appears from the name plate of the pump). See also spare parts drawing with item Nos.

13. OPERATING DATA

The following max. working pressures are allowed:

PUMP	S32-25-110	S50-32-135N	S70-50-175N	S70-50-220N	S70-50-275N
PRESSURE mWC	45	45	65	100	150
Pump	S80-70-175N	S80-70-220N	S80-70-275N	S100-80-175N	S100-80-220N
PRESSURE mWC	65	100	160	65	100
Pump	S100-80-275N	S125-80-220N	S125-80-275N	S125-100-220N	
PRESSURE mWC	150	100	150	100	

(10.2 mWC = 1 bar)

The powers stated in the table below are the highest possible absorbed by the pump, whereas the min./max. values for flow and pressure indicate DESMI's recommended operating range for the pump.

The above-mentioned max. working pressure is **NOT** valid for pumps approved by a classification society. Pumps approved by classification societies have been pressure tested according to the requirements of these societies, i.e. a test pressure of 1.5 x the permissible working pressure. The test pressure is stated in the test certificate and stamped into the discharge flange of the pump.

Pump	Max. Power kw 1450/1750/ 2950/3500 RPM	Min. Flow m ³ /h 1450/1750/ 2950/3500 RPM	Max. Flow m ³ /h 1450/1750/ 2950/3500 RPM	Min. Pressure mWC 1450/1750/ 2950/3500 RPM	Max. Pressure mWC 1450/1750/ 2950/3500RPM
S32-25-110	0.2/0.3/0.9/1.4	2.5/3.0/4.5/5.5	6.0/7.0/12.0/13.5	1.7/2.8/8.0/12.5	3.6/5.3/15.0/21
S50-32-135N	0.3/0.5/2.1/3.5	4,0/4,5/8,0/9,0	11,0/13,5/23/27	3.0/4.2/12.0/17.8	6.0/8.7/25/35
S70-50-175N	0.8/1.2/6.0/10.0	8.0/10.0/17.5/20	20/24/45/53	5.6/8.4/19.0/27	9.2/13.5/38/53
S70-50-220N	1.6/2.7/12.3/20.5	8.0/9.0/15/20	24/27/45/55	5.5/9.5/31/40	14.2/21/63/86
S70-50-275N	3.5/6.0/22/35	10.0/12.0/14.0/16.0	26/32/32/38	16.0/21/88/123	24/34/103/143
S80-70-175N	1.1/1.8/8.3/13.5	16.0/17.5/30/35	39/48/80/95	4.6/6.0/16.5/23	8.7/12.5/36/50
S80-70-220N	2.4/4.2/18.5/31	15.5/18.5/30/35	43/53/80/95	9.5/13.0/42/59	15.5/22/64/90
S80-70-275N	4.4/7.4/32/53	15.0/18.0/30/35	40/50/80/95	16/22/67/94	25/36/103/143
S100-80-175N	1.6/2.8/12.5/21	30/35/60/70	70/85/150/170	4.6/6.2/15.0/24	8.3/12.2/34/48
S100-80-220N	3.5/6.1/27/47	28/37/58/80	85/97/170/190	7.0/9.2/31/48	14.6/21/60/82
S100-80-275N	6.8/12.0/55/92	35/40/70/80	85/100/160/180	13.5/19.5/60/90	23/33/93/130
S125-80-220N	4.5/8.0/36.5/61	60/65/100/120	135/150/240/250	5.3/10.0/30/54	12.4/19.0/55/77
S125-80-275N	8.5/15.0/70/118	50/60/100/120	120/145/220/260	14.0/19.8/62/88	24/34/94/131
S125-100-220N	5.4/9.5/46/74	70/85/140/140	170/200/300/320	6.7/10.2/34/54	12.2/17.8/51/73

14. EC DECLARATION OF CONFORMITY

DESMI PUMPING TECHNOLOGY A/S, hereby declare that our pumps of the type Modular S-N Monobloc are manufactured in conformity with the following essential safety and health requirements in the COUNCIL DIRECTIVE 2006/42/EC on machines, Annex 1.

The following harmonized standards have been used:

EN/ISO 13857:2008	Safety of machinery. Safety distances to prevent danger zones being reached by the upper limbs
EN 809:1998 + A1:2009	Pumps and pump units for liquids – Common safety requirements
EN12162:2001+A1:2009	Liquid pumps – Safety requirements – Procedure for hydrostatic testing
EN 60204-1:2006 /A1:2009	Safety of machinery – Electrical equipment of machines (item 4, General requirements)

Pumps delivered by us connected with prime movers are CE-marked and comply with the above requirements.

Pumps delivered by us without prime movers (as partly completed machinery) must only be used when the prime mover and the connection between prime mover and pump comply with the above requirements.

Nørresundby, March 05 2019



Henrik Mørkholt Sørensen
Managing Director

DESMI Pumping Technology A/S
Tagholm 1
9400 Nørresundby

15. INFORMATION RELEVANT FOR DISASSEMBLY OR DISPOSAL AT END-OF-LIFE

No damage materials are used in DESMI pumps – please refer to DESMI Green Passport (can be sent on request – contact a DESMI sales office) – i.e. common recycling companies can handle the disposal at end-of-life. Alternatively the pump and motor can be returned to DESMI at end-of-life for safe recycling.

16. ASSEMBLY DRAWINGS

16.1 Assembly drawing for pumps bigger than S32-25-110 and S50-32-135N

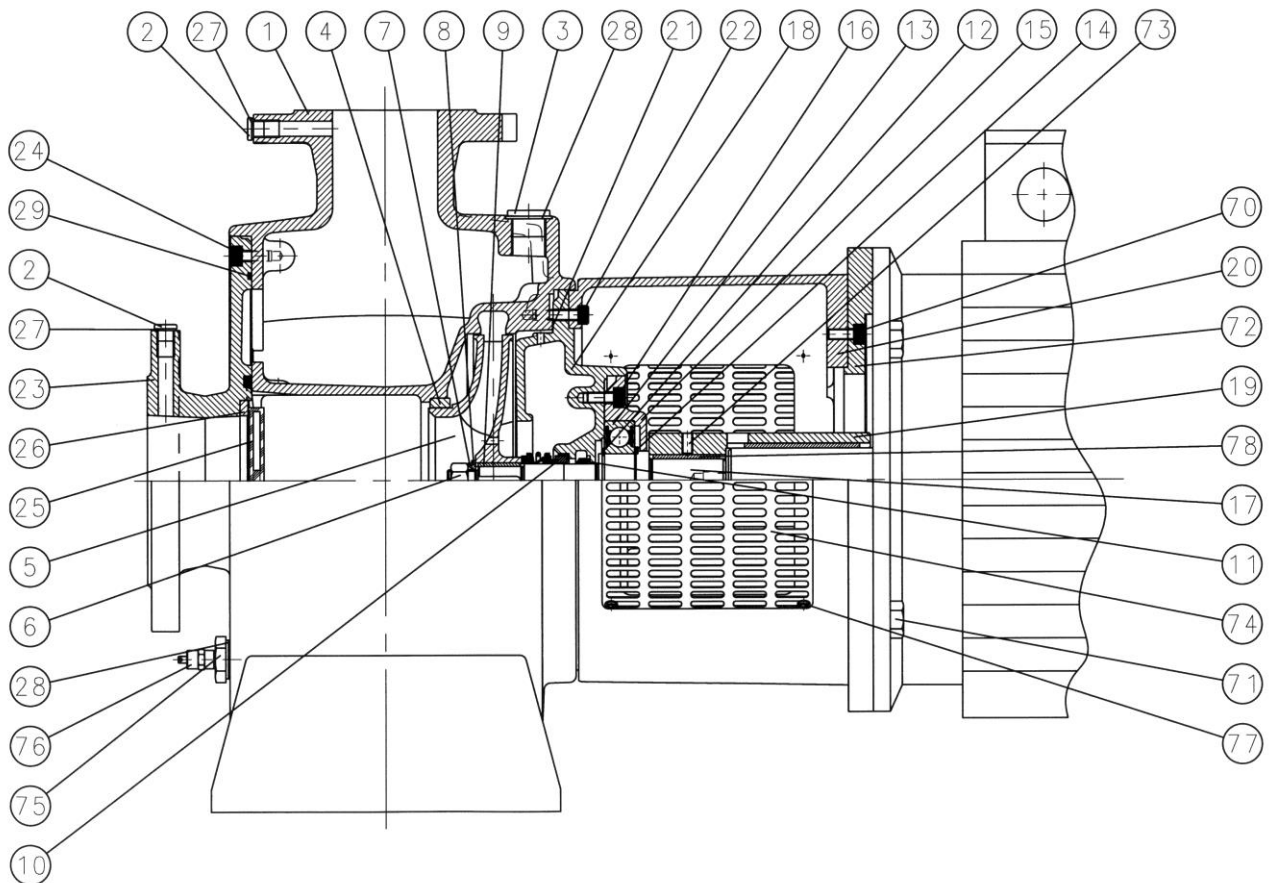

16.2 Assembly drawing for S32-25-110 and S50-32-135N

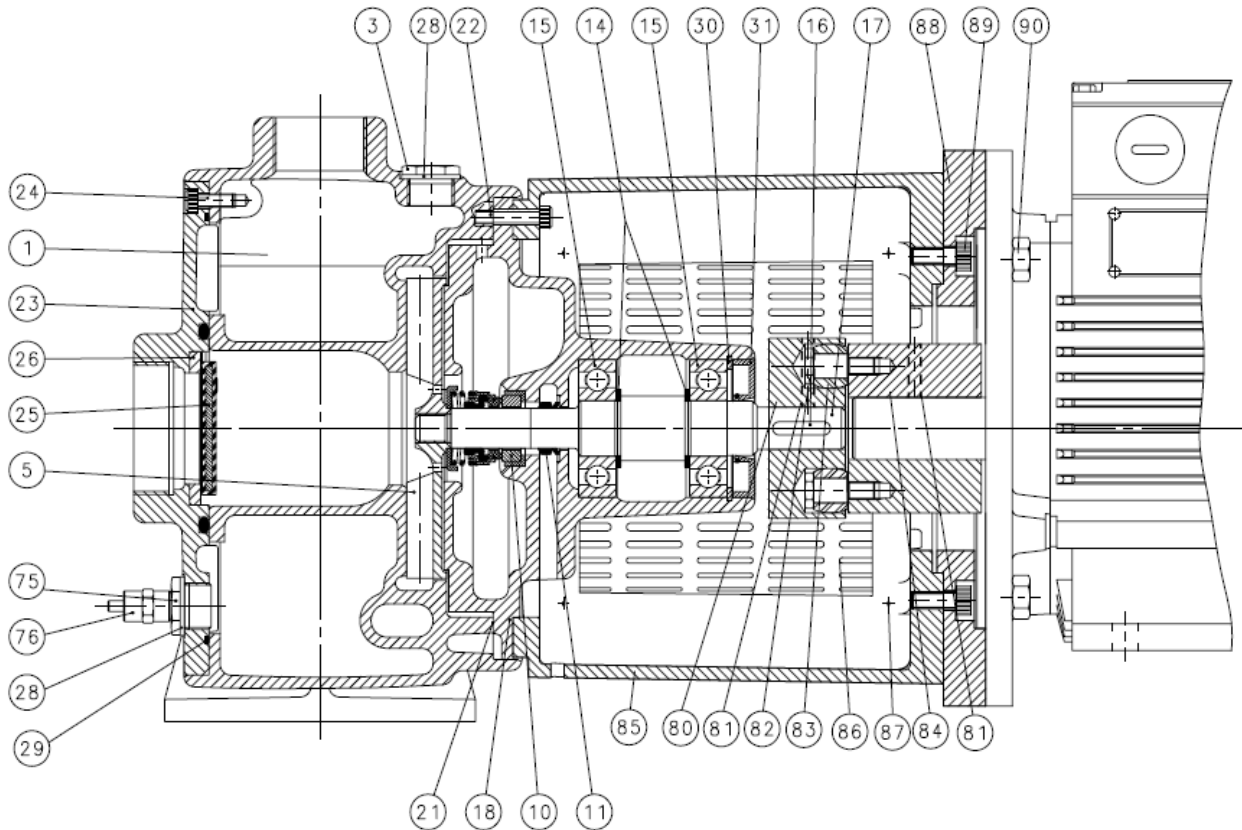

17. SPARE PARTS LISTS

17.1 Spare parts list for pumps bigger than S32-25-110 and S50-32-135N

1 Pump casing	15 Bearing cover	29 O-ring
2 Pipe plug	16 Allen screw	70 Set screw
3 Pipe plug	17 Shaft	71 Allen screw
4 Sealing ring	18 Shaft seal cover	72 Intermediate flange
5 Impeller	19 Coupling	73 Pointed screw
6 Nut	20 Motor bracket	75 Drain plug
7 Spring collar	21 Gasket	76 Relief valve
8 Washer	22 Allen screw	77 INSEX screw
9 Sunk key	23 Inlet	78 Sunk key
10 Mech. shaft seal	24 Allen screw	
11 Water deflector	25 Non-return flap	
12 Ring lock	26 Valve plate	
13 Ball bearing	27 Sealing washer	
14 Support disc	28 Sealing washer	

17.2 Spare parts list for S32-25-110 and S50-32-135N

1	Pump casing	29	O-ring
3	Pipe plug	30	Snap ring
5	Impeller	31	Oil sealing ring
10	Mech. shaft seal	75	Drain plug
11	Water deflector	76	Relief valve
14	Support disc	80	Coupling pump half
15	Bearing	81	Point screw
16	Sunk Key	82	Screw
17	Shaft	83	Rubber ring
18	Shaft sealing cover	84	Coupling motor half
21	Gasket	85	Motor bracket
22	Allen Screw	86	Coupling guard
23	Inlet	87	Screw
24	Allen screw	88	Intermediate flange
25	Non-return flap	89	Allen screw
26	Valve plate	90	Screw
28	Sealing washer		

18. DIMENSIONAL SKETCH

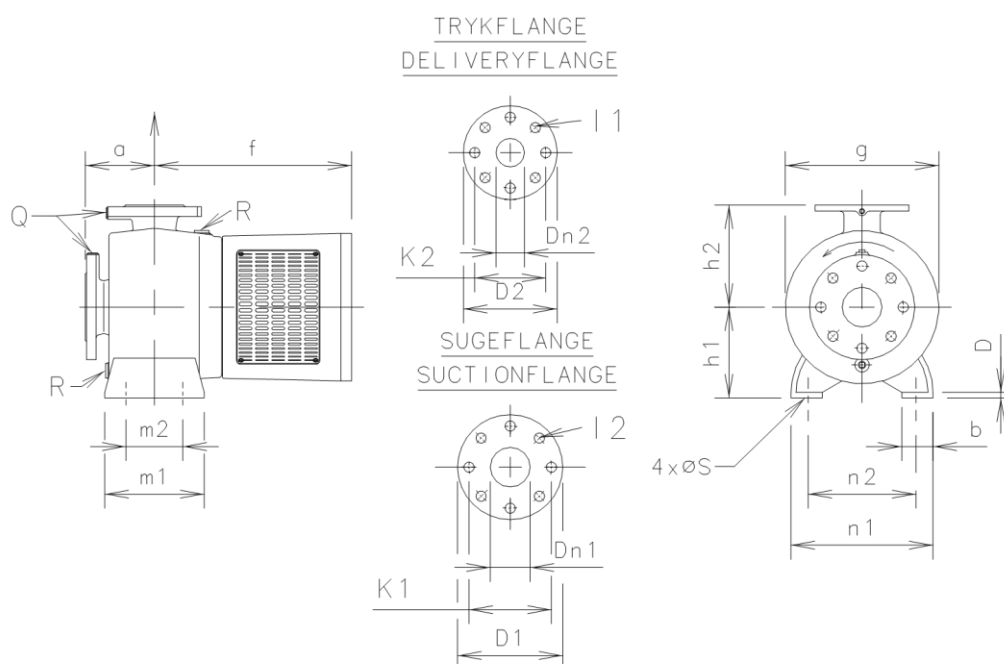

See also table on the next page

Type	m2	ml	n2	nl	b	D	S	h1	h2	l1
S32-25-110	110	140	160	235	59	10	12	132	155	-
S50-32-135N	110	140	160	230	59	10	12	132	140	-
S70-50-175N	160	175	190	250	55	10	15	160	180	4x18
S70-50-220N	170	240	230	300	68	12	15	190	220	4x18
S70-50-275N	210	189	280	345	65	12	19	225	240	4x18
S80-70-175N	190	220	200	273	69	13	15	180	200	8x18
S80-70-220N	190	220	230	305	70	12	15	190	220	8x18
S80-70-275N	170	210	280	360	75	12	19	225	250	8x18
S100-80-175N	220	270	230	319	72	13	15	200	240	8x18
S100-80-220N	225	265	265	365	90	15	19	250	280	8x18
S100-80-275N	225	265	280	380	90	14	19	250	280	8x18
S125-80-220N	300	260	280	382	95	16	19	250	280	8x18
S125-80-275N	260	300	320	414	90	14	19	260	300	8x18
S125-100-220N	330	370	320	445	105	16	19	280	315	8x18

Type	l2	g	a	f	Dn1	K1	D1	Dn2	K2	D2	Q	R
S32-25-110	-	234	100	300	1 1/4" BSP suction – 1" discharge						1/2" BSP	
S50-32-135N	-	234	84	300	2" BSP suction – 1 1/4" discharge						1/2" BSP	
S70-50-175N	4x18	270	125	347	70	145	185	50	125	165	1/4" BSP	1/2" BSP
S70-50-220N	4x18	330	134,5	348	70	145	185	50	125	165	1/4" BSP	1/2" BSP
S70-50-275N	4x18	390	140	407	70	145	185	50	125	165	1/4" BSP	1/2" BSP
S80-70-175N	4x18	295	150,5	355	80	160	200	70	145	185	1/4" BSP	1/2" BSP
S80-70-220N	4x18	330	155	361	80	160	200	70	145	185	1/4" BSP	1/2" BSP
S80-70-275N	4x18	390	150	417	80	160	200	70	145	185	1/4" BSP	1/2" BSP
S100-80-175N	8x18	344	175,5	379	100	180	220	80	160	200	1/4" BSP	1/2" BSP
S100-80-220N	8x18	400	180	370	100	180	220	80	160	200	1/4" BSP	1/2" BSP
S100-80-275N	8x18	425	180	431	100	180	220	80	160	200	1/4" BSP	1/2" BSP
S125-80-220N	8x18	424	204	446	125	210	250	80	160	200	1/4" BSP	1/2" BSP
S125-80-275N	8x18	454	202	446	125	210	250	80	160	200	1/4" BSP	1/2" BSP
S125-100-220N	8x18	476	235	466	125	210	250	100	180	220	1/4" BSP	1/2" BSP