

## CHD service manual

### ROTAN CHD Pumps Annex to Manual T1456

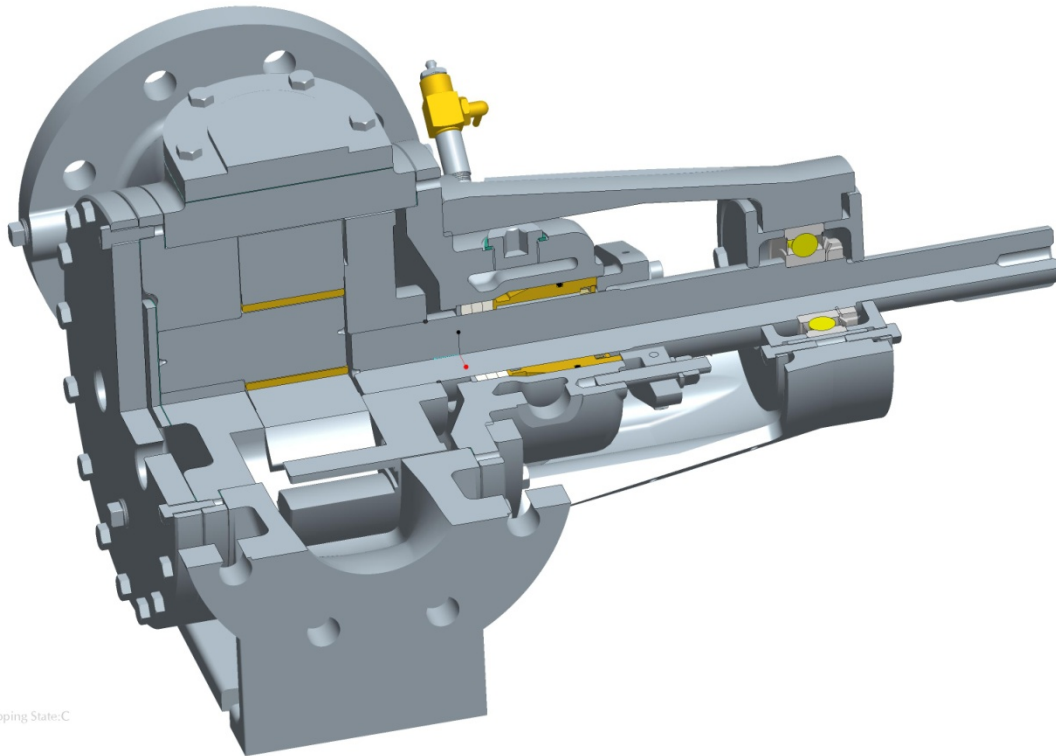

Clipping State-C

**DESMI Pumping Technology A/S**  
**Tagholm 1 – DK-9400 Nørresundby – Danmark**

Tel.: +45 96 32 81 11  
Fax: +45 98 17 54 99  
E-mail: [desmi@desmi.com](mailto:desmi@desmi.com)  
Internet: [www.desmi.com](http://www.desmi.com)

T1507UK-V.2.0

1. INTRODUCTIONS .....	- 2 -
2. BEFORE START-UP .....	- 7 -
3. MAINTENANCE.....	- 10 -
4. REPLACEMENT OF SOFT PACKING RINGS .....	- 11 -
5. REPLACEMENT OF LIP SEAL.....	- 12 -
6. INSPECTION OF IDLER PIN/BUSHING.....	- 14 -
7. INSPECTION/ADJUSTMENT OF AXIAL CLEARANCE.....	- 16 -
8. SPARE PARTS LIST.....	- 17 -
9. ASSEMBLY DRAWINGS .....	- 18 -
10. SERVICE CENTRES – DENMARK .....	- 21 -
11. SUBSIDIARY COMPANIES – DESMI PUMPING TECHNOLOGY A/S .....	- 22 -

---

Illustrations in this manual are only used to demonstrate the different working procedures. To a degree they are dependent on the size of the pump as there are different model constructions used for different applications

When ordering spare parts the following information must be provided:

- The pump serial number
- The pump SX number
- The spare part Position number

The above information can be found on the pump flanges or the pump's nameplate

## 1. Introductions

This service manual only contains information about startup, service and maintains of Rotan CHD pumps.

For general information about Rotan pumps please refer to manual T1456

Rotan pumps are designed for pumping media with high viscosity such as chocolate, Cocoa Mass , Cocoa Butter, sugar powder etc. The Pump are equipped with heating jacket on the front and rear end. The Rotor, Idler and idler bushing are with special clearances.

The Rotan CHD pumps are not Pressure or flow tested from the factory.  
The front cover and rear cover is pressure tested separately.  
CHD pumps are preserved with vegetable oil.

Rotan CHD pumps are not approved for pumping foods requiring FDA and 3 A approval.

## EC Declaration of Conformity The Machinery Directive 2006/42/EC

**Manufacturer:** DESMI Pumping Technology A/S  
**Address:** Tagholm 1, DK-9400 Nørresundby, Denmark  
**Tel.:** +45 96 32 81 11  
**E-mail:** desmi@desmi.com

DESMI Pumping Technology A/S hereby declares that the product in question has been produced in accordance with the following essential health and safety requirements of the Machinery Directive 2006/42/EC Annex I.

**Product:** ROTAN pumps complete with motor  
**Type:** HD, CD, PD, GP, CC, ED(MD)  
**Serial No:** From 10000-xx-xx to 999999-xx-xx

The following harmonized standards have been applied:

[EN 809 + A1/AC:2010](#) Pumps and pump units for liquids  
[DS/EN 12162 + A1:2009](#) Procedures for hydrostatic testing of liquid pumps

Nørresundby 2015



Claus Dietz Hansen  
Technical Director  
DESMI Pumping Technology A/S

## Declaration of Incorporation”

**Manufacturer:** DESMI Pumping Technology A/S  
**Address:** Tagholm 1, DK-9400 Nørresundby, Denmark.  
**Tel.:** +45 96 32 81 11  
**E-mail:** desmi@desmi.com

**Product:** ROTAN pumps  
**Type:** HD, CD, PD, GP, CC, ED(MD)  
**Serial No:** From 10000-xx-xx to 999999-xx-xx

DESMI Pumping Technology A/S hereby declares that the product in question has been produced in accordance with the following essential health and safety requirements of the Machinery Directive 2006/42/EC Annex I:

The following harmonized standards have been applied:

EN 809:2002 + AC – Pumps and pump units for liquids  
EN 12162 + A1:2009 – Procedures for hydrostatic testing of liquid pumps

**The pump must not be put into service until the final machinery into which the pump has been incorporated into, is declared in conformity with the provisions of the machinery directive 2006/42/EC.**

Nørresundby 2015



Claus Dietz Hansen  
Technical Director  
DESMI Pumping Technology A/S

## EC Declaration of Conformity ATEX – 94/9/EC

**Manufacturer:** DESMI Pumping Technology A/S  
**Address:** Tagholm 1, DK-9400 Nørresundby, Denmark.  
**Tel.:** +45 96 32 81 11  
**E-mail:** desmi@desmi.com



**Product:** ROTAN pumps  
**Type:** HD, CD, PD, GP, CC, ED(MD)

which are marked: Ⓔ II category 2 or 3, "c" X and with temperature class and installed and applied in conformity with DESMI Pumping Technology A/S' user

manual

**The entire user manual must be read thoroughly before a ROTAN ATEX pump is installed and put into use**

DESMI Pumping Technology A/S hereby declares that the product in question has been produced in accordance with ATEX Directive 94/9/EC.

The following harmonised standards have been applied: EN13463-1:2009  
EN13463-5:2011

The product is designed for use when connected to an electric motor, with the aim of creating a joint machine. The conformity also applies to complete pumps with motor if, according to the manufacturer, the motor conforms to a corresponding category and temperature class and has been fitted in conformity with DESMI Pumping Technology A/S' user guide.

If DESMI Pumping Technology A/S supplies pump and electric motor connected, the EC Declaration of Conformity and user manual for the electric motor will be attached.

Nørresundby 2015

A handwritten signature in black ink, appearing to read 'Claus Dietz Hansen', is written over a light grey rectangular background.

Claus Dietz Hansen  
Technical Director  
DESMI Pumping Technology A/S

## MANUFACTURER'S CERTIFICATE

This is to certify that

**DESMI**

Rotan® Chocolate pumps in cast iron (material code 1) and stainless steel (material code 3) type ECHD/BCHD (in line / 90° angle) are designed specifically for the chocolate industry. Consequently all materials - various steel types, sealing materials and surface treatment which are in contact with the product - are suitable for this type of application and according to:

REGULATION (EC) No 1935/2004 OF THE EUROPEAN PARLIAMENT  
AND OF THE COUNCIL of 27 October 2004.

 **DESMI A/S**

Nørresundby d. 05-04-2011.....  
Tagholm 1  
DK-9400 Nørresundby, Denmark  
Phone: +45 96 32 81 11, Fax: +45 98 17 54 99  
Homepage: [www.desmi.com](http://www.desmi.com)  
E-mail: [desmi@desmi.com](mailto:desmi@desmi.com)

## 2. Before start-up

Rotan CHD pumps are preserved with vegetable oil at the factory, If this oil is not compatible with the media that is pumped, the pump should be cleaned before startup.

Rotan CHD pumps is fitted with a special shaft seal, and may not be mistaken for a standard soft shaft packing (see Figure 1)

**WARNING**

The main bushing and the soft packing rings are not lubricated from the factory. The main bushing and the soft packing is to be lubricated before startup. Make sure that the lubrication media is compatible with the media that's is pumped

**WARNING**

When lubricating the main bushing and the soft packing, the lubrication pressure must not exceed 20 bar / 290 psi. If the lubrication pressure exceeds this, there is a risk of damaging the Lip seal and the packing gland.

Prelubrication amounts of main bearing

Prelubrication amount for main bearing	
Pump size HD - CD	Grease in cm3 (cubic centimeters)
33	5,0
41	7,5
51/66	25,5
81/101	27,0
126	24,0
151	28,0
152	42,0

*Remember to close the pet cock valve after lubrication*

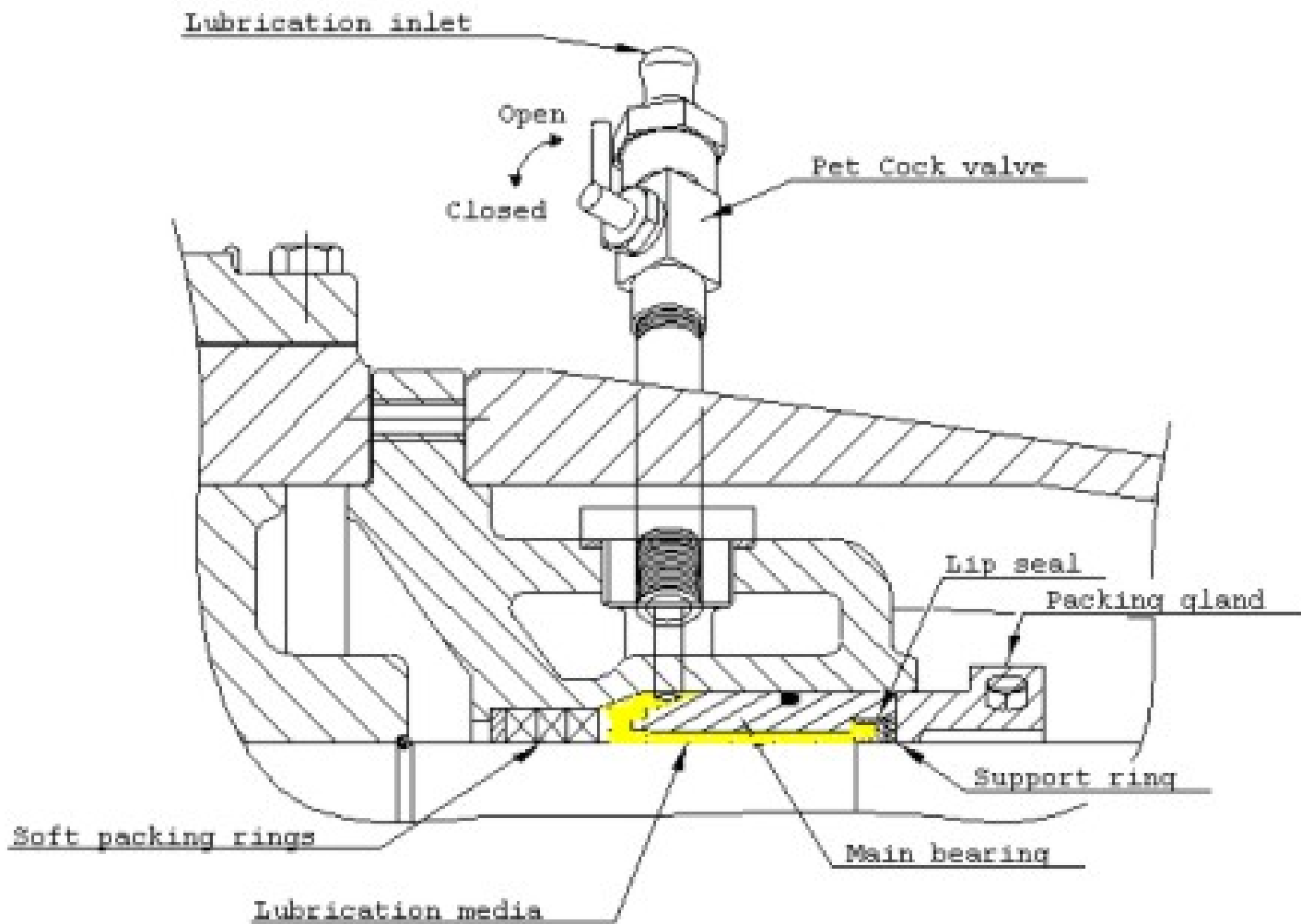

Figure 1. Shows Construction of CHD shaft seal



## Before starting the pump, check:

- That the main bushing and soft packing is lubricated with Food grade grease
- That the pump is correctly aligned with the gear and motor. See chapter: "Aligning the pump and gear/motor" Main manual T1456
- That the pump is heated, to secure a free rotation of the shaft
- That the ball bearings maximum service life is observed See main manual T1456
- That all isolating valves in the suction and pressure pipe are fully open, to avoid the pressure being too high, and the pump running dry
- That there is no coagulated liquid in the pump or pipe system, after last operation, that can cause blockage or breakdown
- That all necessary monitoring and safety system are connected and adjusted according to the operation conditions

## After starting the pump, check:

- That the pump is drawing the liquid
- That there are no signs of cavitation i.e. excessive noise and or vibration
- That the speed is correct
- That the direction of rotation is correct
- That there is no leakage from the pump
- That the shaft seal not leaking  
(the shaft seal on a CHD pump is a isolated construction and there for leak free)
- That the operation pressure is correct
- That the pressure in the heating jackets not exceeds 10 bar
- That the magnetic clutch (type ED) is not slipping and then causing an inadequate flow. And that the temperature in the magnetic clutch does not exceed the permitted
- That the power consumption is correct
- That all surveillance equipment is working correctly
- That any pressurized water pipes, Heating/cooling and lubricating systems, etc. are working correctly

## 3. Maintenance

Normal Maintenance of the Rotan CHD pumps will typically include the following.

1. Lubrication of the soft shaft seal and main bushing
2. Inspection of leakage from the lip seal (the lip seal is leak free)
3. Inspection of wear on the idler pin and idler bushing

The implementation of the above mentioned maintenance points, can vary a lot, depending of the operations conditions.

DESMI Pumping Technology A/S recommend that the soft packing and main bushing is lubricated at an 8 hour intervals (see diagram below) it is important that the lubrication interval is adjusted to the operations conditions, so that the media is kept away from the main bushing and lip seal. Automatic grease pots may be fitted

After roughly one month operation it is recommended that the front cover is removed for inspection for wear on the idler pin/bushing, and disassembly of the rear end for inspection of wear on the shaft – main bushing and the lip seal if there is traces of the pumped media in the main bushing, it is recommended that the lubrication interval is adjusted.

The operating conditions, can be very different, so it is recommended that the company work out a procedure for servicing the pumps (lubrications interval, inspection of wear) that is adjusted to the pump operation conditions.

Lubrication of slide bearings CHD		
Fat quantity in grams		
Pump type: HD – CD – ED	Relubrication interval in hours	Main bearing
33	8 hours	1
41		1
51		1,5
66		1,5
81		2
101		2,5
126		4
151		6
152		10

## 4. Replacement of soft packing rings

The Rotan CHD pumps are constructed with a split packing gland follower, which allows the main bearing bushing to be pulled out of the pump and the soft packing rings can be replaced.

Remove the nut (pos. BE) and pull back the packing gland (pos. BB) along with the main bushing (pos. BC). Remove the bolts in the packing gland (pos. EJ), pull the main bushing as far back as possible. Gently Use a Flexible Packing Extractor for pulling out the soft packing rings (pos. CJ). Clean the area before, replacing them with new ones.

**WARNING**

If the nuts (pos. BE) are tightened too hard it can result in high heat generation, and poor lubrication of the soft packing rings. Under these conditions there is a very high risk of damaging the soft packing rings and the shaft

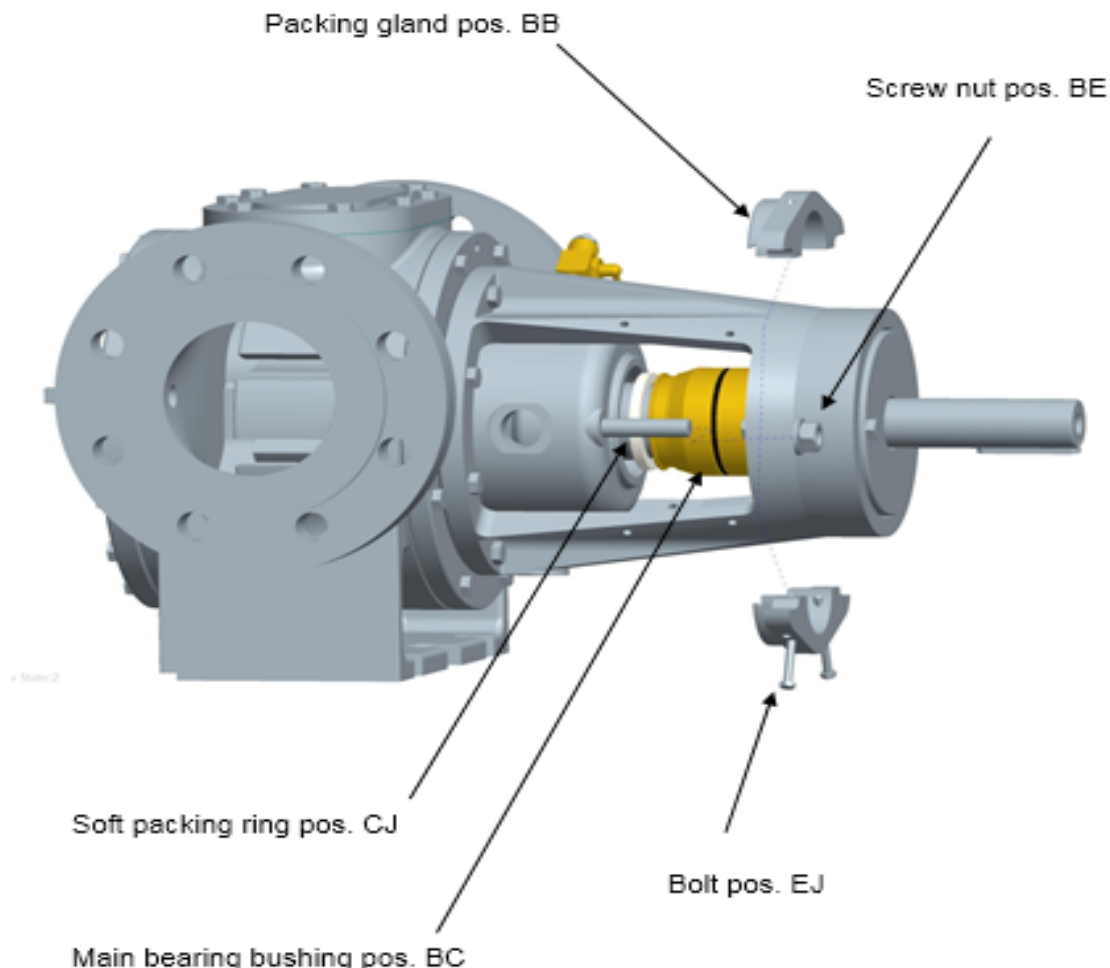

## 5. Replacement of Lip seal

When replacing the Lip seal (pos. EG) in the main bushing  
The rear end is to be dismantled. See figure 2

Rotan pumps are constructed with a back pull out system that allows the pump casing to remain in the pipe system  
Whilst the rear end is removed as show in figure. a

Remove the bolts pos. F  
Remove the rear end.

The rear end is now ready to be dismantled.  
The Lip seal pos. EG. Can be replaced.

Use the proper tools to remove the ball bearing.

Clean all components before assembling them.

The rear end is now ready to be mounted in the pump casing, Remember to check/adjust the axial clearance see chapter "Inspection/adjustment of axial clearance".

**WARNING**

Remember to lubricate the soft packing and main bushing before starting up the pump.

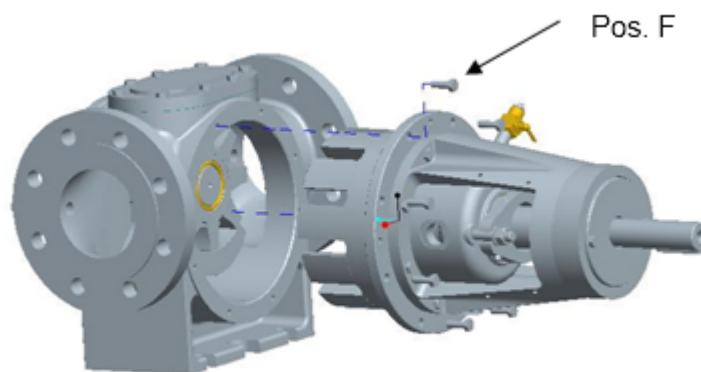
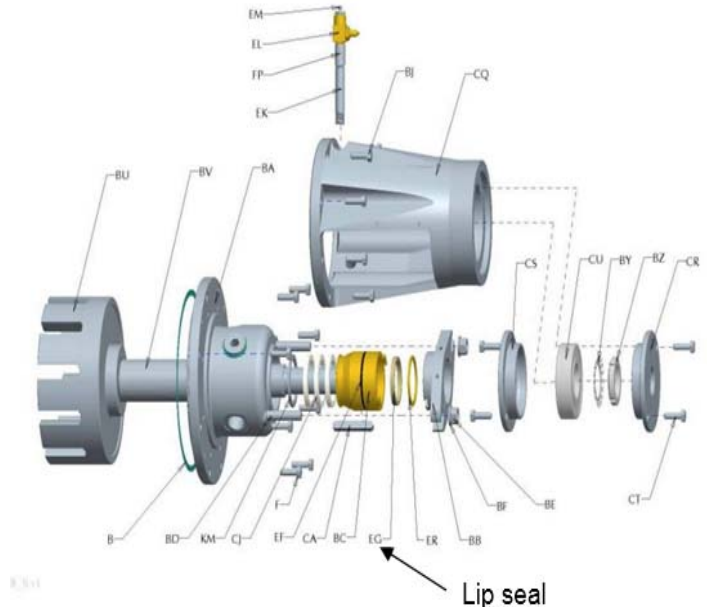
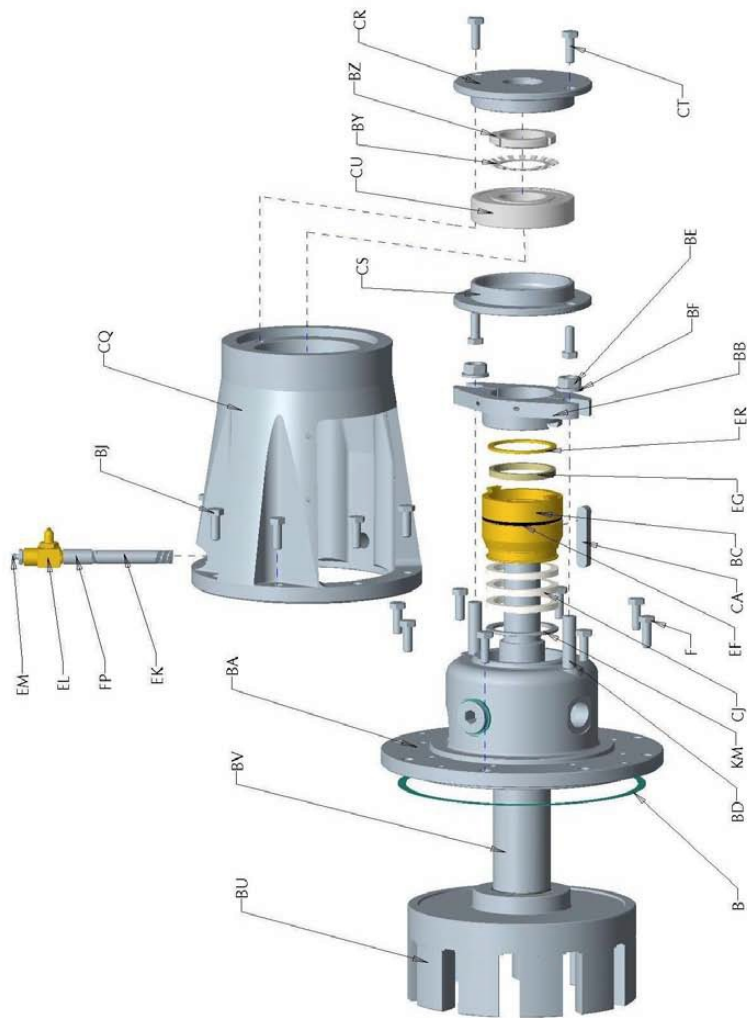

Figure. a



Explode State: BAGENDE\_1(+)

Figure. 2 Exploded view of rear end

## 6. Inspection of Idler pin/Bushing

Remove the bolts pos. E. and gently pull out the front cover including the Heating jackets (figure. 3)

Be careful that the idler doesn't fall down when removing the front cover

Pump size 81 to 201 use proper lifting equipment.

Clean the front cover, and inspect the idler pin Poss. AC For Wear (figure. 4)

Clean the idler busing pos. AD and inspect it for wear (figure. 5)

See figure 7 for measuring wear on idler pin and busing

Clean the packing surface on the front cover and pump before mounting the front cover on the pump again

From the size 81 to 152 the Idler is manufactured with a tapered surface between the teeth, the idler is placed on the idler pin with the tapered surface pointing against the front cover. See Figure 6

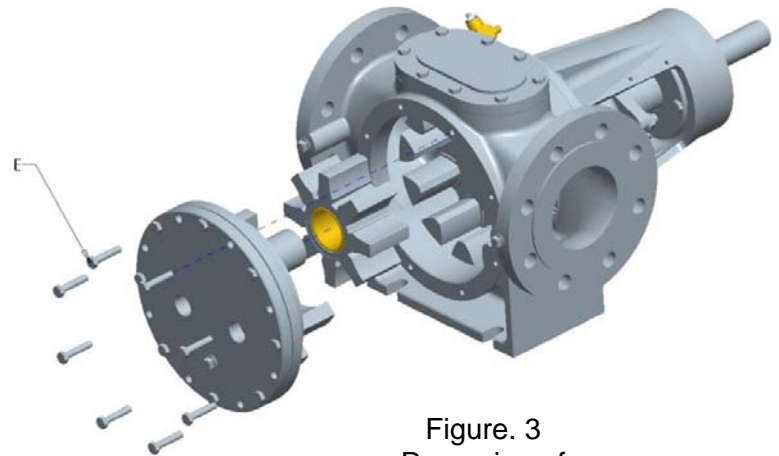

Figure. 3  
Removing of front cover

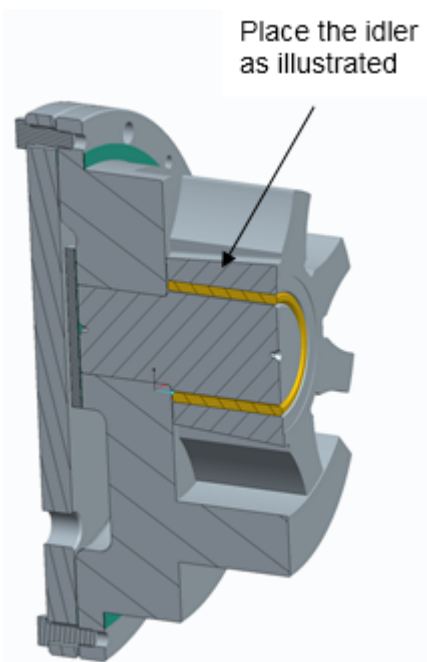

Figure. 6

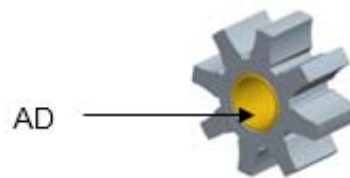

Figure. 5 Idler

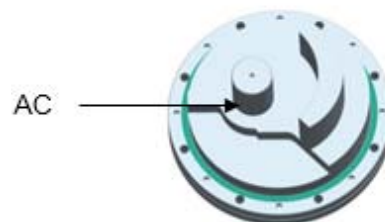

Figure.4 Front cover

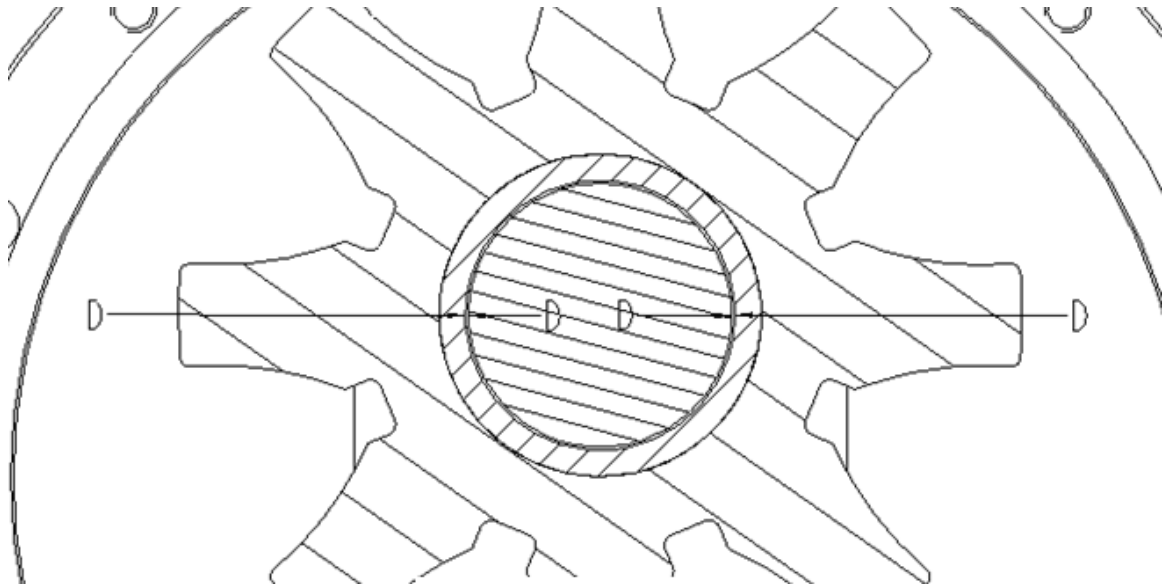

Figure. 7

Pump Size	Recommended Clearance after wear D+D max(mm)
41	1,5
51	1,7
66	1,7
81	1,7
101	1,7
126	1,8
151	1,8
152	1,8

Figure. 8

## Measuring of wear

Measure the diameter on the idler pin and the diameter on the idler bushing the clearance must not exceed measurements stated in the above table (Figure 8)



## 7. Inspection/adjustment of axial clearance

The axial clearance is the distance between rotor and front cover

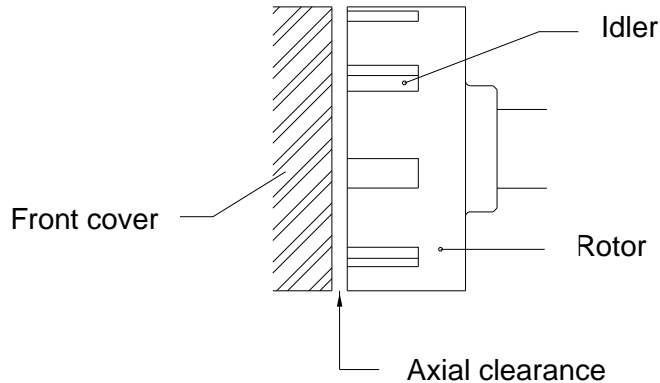

Figure. 9 Shows the axial clearance between rotor and front cover.

The axial clearance is pre-set at factory.

It might be necessary to adjust the axial clearance after repairing the pump or in case of wear

The axial clearance is inspected as followed

The pumps axial clearance is measured with a flat feeler gauge. The flat feeler gauge is inserted through the pump inlet or outlet, between the front cover, idler and rotor

### Adjustment of axial clearance

The axial clearance is adjusted by turning the adjustments screws

**Type HD, CD** Adjustments screws pos. CT

**Type ED:** Adjustments screws pos. E/NM

Axial clearence CHD							
Pump size		26/33	41	51/66	81/101	126/151	152
CHD*	Min.	0,20	0,20	0,30	0,40	0,60	0,70
	Max.	0,25	0,30	0,40	0,50	0,75	0,90
Stainless pumps**	Is adjusted with 0,10mm larger clearance than stated above						

The adjustments screws is to be turned in pairs and in the same angle.

Figure:11 Show the axial clearance in mm for the different pump sizes.

\*\* Pumps in stainless steel is to be adjusted with 0,10mm larger clearance than stated above.

Pumps in stainless steel is recognized by a 3 in the pump code example: CD26EFCHD-3M22B



## 8. Spare parts List

When ordering spare parts the following information must be provided:

- The pumps serial number
- The pumps SX number
- The spare part Possession number

The above information can be found on the pump flanges or the pump's nameplate

Position number

A = Pump casing  
B = Gasket  
C = Gasket  
D = Bolt  
E = Bolt  
F = Bolt  
G = Pipe plug  
J = Drive screw  
S = Blind cover  
AA = Front cover  
AB = Idler  
AC = Idler pin  
AD = Idler bushing  
AF = Gasket  
AJ = Heating jacket

AK = Bolt  
AL = Pipe plug  
BA = Rear cover  
BB = Packing gland  
BC = Main bearing bushing  
BD = Stud bolt  
BE = Nut  
BF = Washer  
BG = Pipe plug  
BH = Pipe plug  
BJ = Bolt  
BK = Pipe plug  
BL = Lubrication sign CHD  
BU = Rotor

BV = Shaft  
BY = Ball bearing nut  
BZ = Ball bearing lock ring  
CA = Key  
CB = Key  
CE = Snap ring  
CJ = Packing coil  
CQ = Bracket  
CR = Bearing cover  
CS = Bearing cover  
CT = Bolt  
CU = Ball bearing  
EF = O-ring  
EG = Seal ring  
EJ = Bolt

EK = Nipple  
EK = Nipple  
EL = Bibcock  
EM = lubricating nipple  
ER = Support ring  
FP = Welding sleeve  
HE = Bolt  
HG = Cover plate for idler pin  
HH = Screw  
HE = Bolt  
HF = Washer  
HR = Gasket  
JL = Gasket  
KM = Spacer ring

## 9. Assembly drawings

Assembly drawings for Rotan CHD pumps Size 33 to 201

Size 33

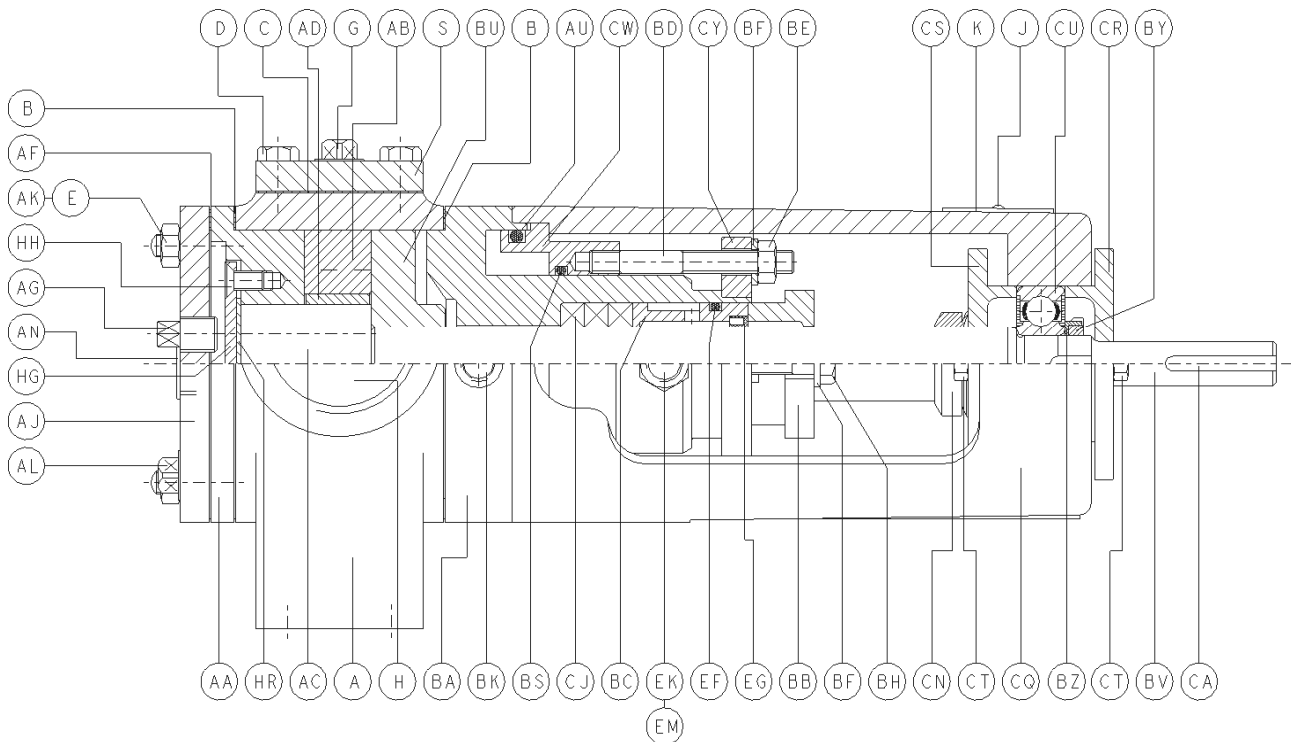

TYPE : DRAFT NAME : NONE SIZE : 400 by 250

Size 41

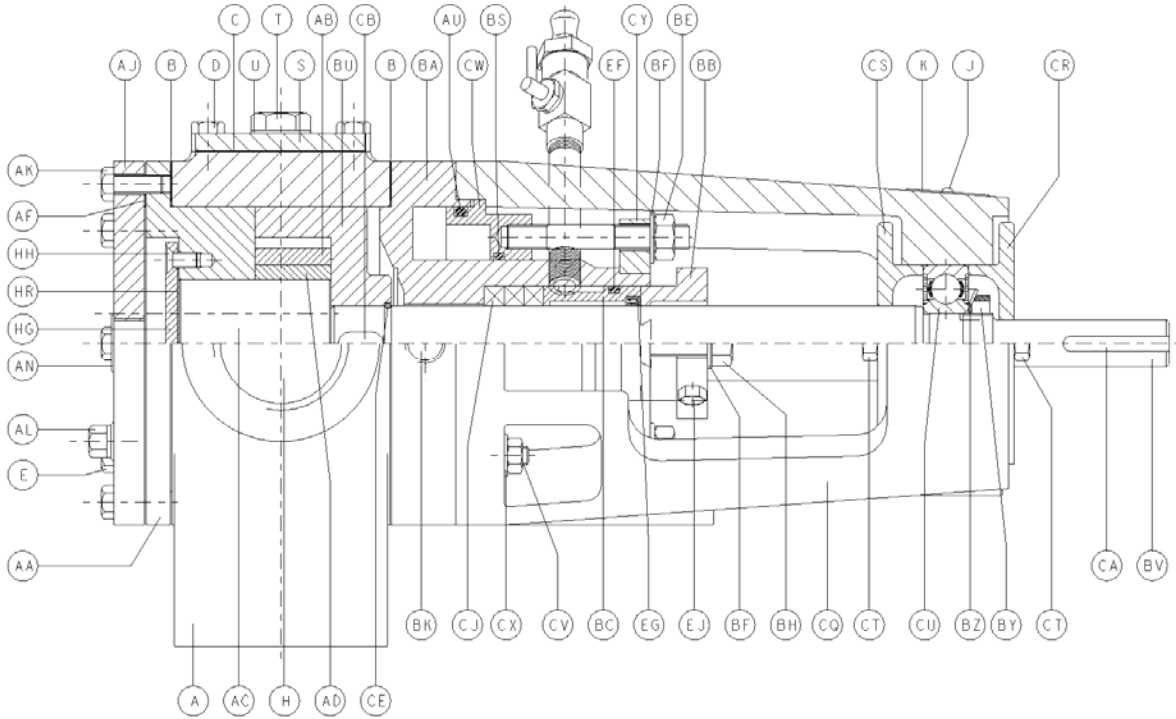

Size 51-66

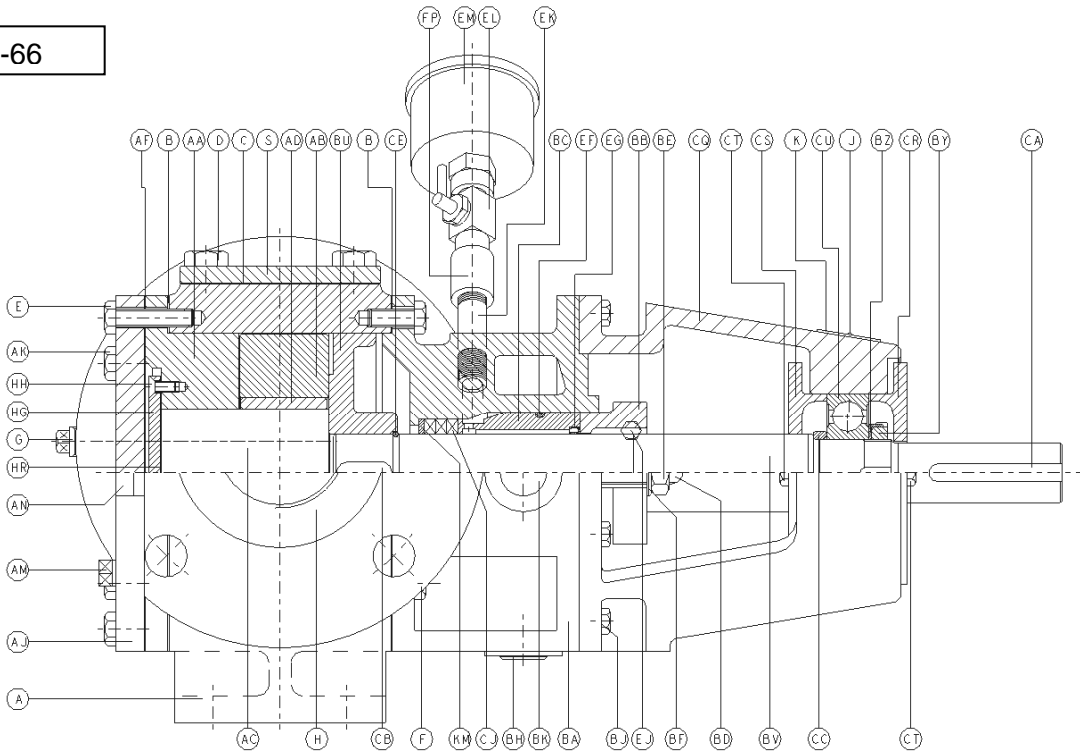

TYPE : DRAFT NAME : NONE SIZE : A2

Size 81

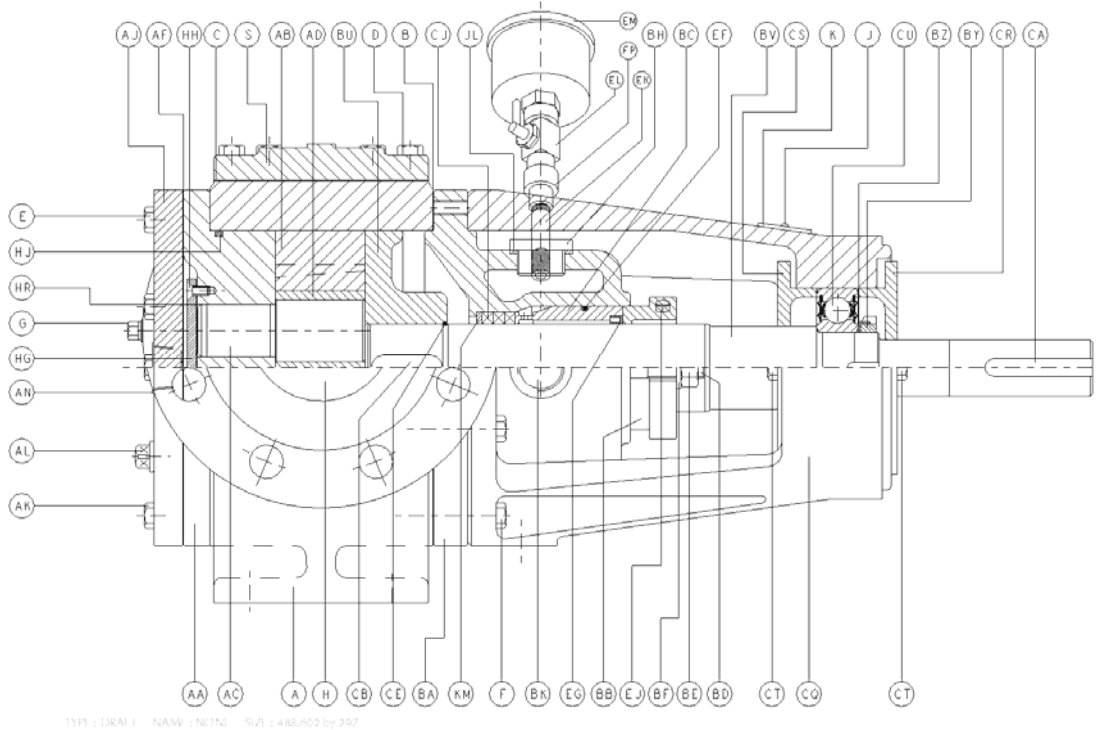

Size 101 - 152

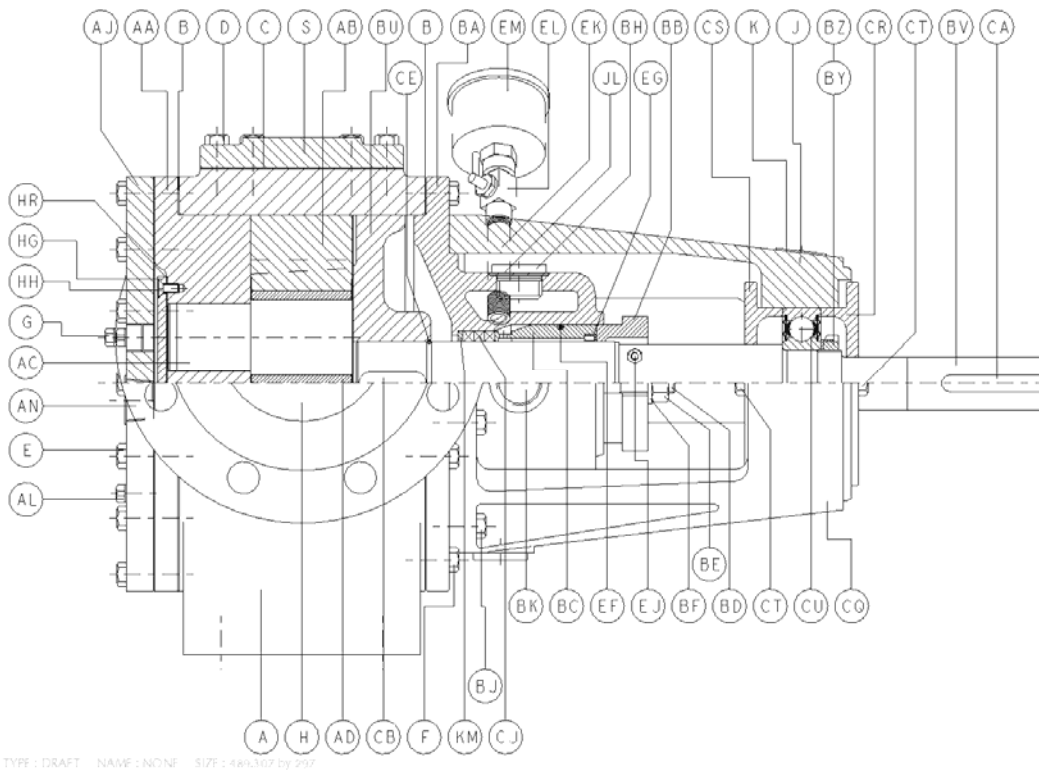

## 10. Service centres – Denmark

Service center - Denmark	
<p>Nørresundby  <b>Tagholm 1</b>  <b>DK-9400 Nørresundby</b>  <b>Tel: +45 70236363</b>  <b>Fax: +45 9817 5499</b></p>	<p><b>Kolding</b>            Albuen 18 C            DK-6000 Kolding            Tel: +45 7023 6363            Fax: +45 75 58 34 65</p>
<p><b>Århus</b>            Lilleringvej 20            DK-8462 Harlev J            Tel: +45 7023 6363            Fax: +45 8694 2292</p>	<p><b>Hvidovre</b>            Stamholmen 173            DK-2650 Hvidovre            Tel: +45 70236363            Fax: +45 3677 3399</p>
<p><b>Odense</b>            Hestehaven 61            DK-5260 Odense S            Tel: +45 70236363            Fax: +45 6595 7565</p>	

## 11. Subsidiary companies – DESMI Pumping Technology A/S

Subsidiary companies – DESMI Pumping Technology A/S	
<b>DESMI Denmark A/S</b> <b>Address:</b> Tagholm 1,DK-9400 Nørresundby Denmark <b>Tel:</b> +45 7244 0250 <b>Fax:</b> +45 9817 5499	<b>DESMI Inc.</b> <b>Address:</b> 4021 Holland Blvd, Chesapeake Virginia 23323, USA <b>Tel.:</b> +1 757 857 7041 <b>Fax.:</b> +1 757 857 6989
<b>DESMI Contracting A/S</b> <b>Address:</b> Tagholm 1,DK-9400 Nørresundby Denmark <b>Tel.:</b> +45 96 32 81 11 <b>Fax:</b> +45 98 17 54 99	<b>DESMI Pumping Technology (Suzhou) Co., Ltd</b> <b>Address:</b> No 740 Fengting avenue, Weiting Sub-District 215122 SIP Suzhou, China <b>Tel.:</b> +86 512 6274 0400 <b>Fax.:</b> +86 512 6274 0418
<b>DESMI GmbH</b> <b>Address:</b> An der Reitbahn 15 21218 Seevetal, Germany <b>Tel.:</b> +49 40 7519 847 <b>Fax:</b> +49 40 7522 040	<b>DESMI Korea</b> <b>Address:</b> 905 ,Western Tower I, Janghang-dong 867, Ilsandong-gu, Goyang, Gyeonggi 410-838, Korea <b>Tel.:</b> +82 31 931 5701 <b>Fax.:</b> +82 31 931 5702
<b>DESMI Ltd.</b> <b>Address:</b> “Norman House” Rosevale Business Park, Parkhouse industrial Estate (West) Newcastle, Staffordshire ST5 7UB, England <b>Tel.:</b> +44 1782 566 900 <b>Fax.:</b> +44 1782 563 666	<b>DESMI Singapore Pte.Ltd</b> <b>Address:</b> No. 8 Kaki Bukit Road 2, Ruby Warehouse Complex Unit no: # 02-16 Singapore 417841 <b>Tel.:</b> +65 6748 2481 <b>Fax.:</b> +65 6747 6172
<b>DESMI B.V</b> <b>Address:</b> Texasdreef 7,3565 CL Utrech Netherlands <b>Tel.:</b> +31 3026 610 024 <b>Fax.:</b> +31 302 623 314	<b>DESMI India</b> <b>Address:</b> 413,Adity Trade Centre Ameerpet, Hyderabad - 500016 <b>Tel.:</b> +91 9949339054
<b>DESMI Norge AS</b> <b>Address:</b> Vigevejen 46, 4633 Kristiansand S, Norway <b>Tel.:</b> +47 38 122 180 <b>Fax.:</b> +47 38 122 181	<b>DESMI Africa</b> <b>Address:</b> Plot No.1848 Yarht Club Road Msasani Peninsular, Dar es Salaam,Tanzania <b>Tel.</b> +255 769756919

