

OPERATION AND MAINTENANCE INSTRUCTIONS

DESMI end suction centrifugal pump NSLV and NSLH Monobloc



DESMI Pumping Technology A/S

Tagholm 1 – DK-9400 Nørresundby – Denmark

Tel.: +45 96 32 81 11

Fax: +45 98 17 54 99

E-mail: desmi@desmi.com

Internet: www.desmi.com

Manual: T1524	Language: English	Revision: M(09/24)
------------------	----------------------	-----------------------

Special pump No.



TABLE OF CONTENTS:	PAGE
1. PRODUCT DESCRIPTION	4
1.1 DELIVERY	4
2. TECHNICAL DATA	4
2.1 EXPLANATION OF THE TYPE NUMBER	4
2.2 TECHNICAL DESCRIPTION	6
3. INSTALLATION	7
3.1 MOUNTING/FASTENING	7
3.2 WIRING	7
4. TRANSPORT/STORAGE	8
5. DISMANTLING	9
5.1 ACCESS TO IMPELLER	9
5.2 DISMANTLING SHAFT SEAL	10
5.3 DISMANTLING SEAT	10
5.4 DISMANTLING BEARING (ONLY 02-COMBINATION)	10
5.5 INSPECTION	11
5.6 DISMANTLING COUPLING (02-COMBINATION) / SHAFT (12-COMBINATION)	12
6. ASSEMBLING	12
6.1 TIGHTENING TORQUES	12
6.2 FITTING SEALING RINGS	13
6.3 FITTING BEARING (ONLY 02-COMBINATION)	14
6.4 FITTING WATER DEFLECTOR (ONLY 02-COMBINATION)	14
6.5 FITTING SHAFT SEAL	15
6.6 FITTING IMPELLER	15
6.7 FITTING SHAFT SEAL COVER OR MOTOR BRACKET (12-COMBINATION)	16
6.9 FITTING COUPLING (ONLY 02-COMBINATION)	16
7. FROST PROTECTION	17
8. DISMANTLING	17
9. START-UP	17
9.1 START-UP	17
10. SYSTEM BALANCING	18
10.1 MECHANICAL SEAL FAILURE ANALYSIS	18
11. INSPECTION AND MAINTENANCE	23
11.1 DRAINING THE PUMP	25
11.2 BEARING	25
12. REPAIRS	27
12.1 ORDERING SPARE PARTS	27
13. OPERATING DATA	27
13.1 ALLOWED MAXIMUM MOTOR FRAME SIZE	27
13.2 MAXIMUM WORKING PRESSURE	28
14. EU & UK DECLARATION OF CONFORMITY	29
15. ATEX DECLARATION OF CONFORMITY	30
15.1 PRODUCT DESCRIPTION	30
15.2 PRECAUTIONS	30
16. INFORMATION RELEVANT FOR DISASSEMBLY OR DISPOSAL AT END-OF-LIFE	31

17. ASSEMBLY DRAWING Ø215/265/ 02-COMB	32
18. SPARE PARTS LIST Ø215/265	32
19. ASSEMBLY DRAWING Ø330/415/465/525 02-COMB	33
20. SPARE PARTS LIST Ø330/415/465/525 WITH HEAVY BEARING HOUSING	33
21. ASSEMBLY DRAWING 300-418 02-COMB.	34
22. SPARE PARTS LIST 300-418 02-COMB.....	34
23. ASSEMBLY DRAWING Ø215/265 12-COMB.....	35
24. SPARE PARTS LIST Ø215/265 12-COMB.....	35
25. ASSEMBLY DRAWING STAINLESS STEEL PUMP Ø215/265 12-COMB.	36
26. SPARE PARTS LIST STAINLESS STEEL PUMP Ø215/265 12-COMB.....	36
27. ASSEMBLY DRAWING Ø330/415/525 12-COMB.....	37
28. SPARE PARTS LIST Ø330/415/525 12-COMB.....	37
29. ASSEMBLY DRAWING 300-418 AND 350-525 12-COMB.	38
30. SPARE PARTS LIST 300-418 AND 350-525 12-COMB.....	38
31. ASSEMBLY DRAWING 65-265/-02 WITH INDUCER.....	39
32. SPARE PARTS LIST 65-265/-02 WITH INDUCER.....	39
33. ASSEMBLY DRAWING 100-265/-02 WITH INDUCER.....	40
34. SPARE PARTS LIST 100-265/-02 WITH INDUCER.....	40
35. ASSEMBLY DRAWING 100-330/-02 AND 100-465/-02 WITH INDUCER.	41
36. SPARE PARTS LIST 100-330/-02 AND 100-465/-02 WITH INDUCER.....	41
37. ASSEMBLY DRAWING 125-330/-02 WITH INDUCER.....	42
38. SPARE PARTS LIST 125-330/-02 WITH INDUCER.....	42
39. ASSEMBLY DRAWING 150-465/-02 WITH INDUCER.....	43
40. SPARE PARTS LIST 150-465/-02 WITH INDUCER	43
41. ASSEMBLY DRAWING 300-415/-02 WITH INDUCER.....	42
42. SPARE PARTS LIST 300-415/-02 WITH INDUCER	42
43. ASSEMBLY DRAWING NSLH 250-210/300-250/350-310/400-390/500-500/600-630.	43
44. SPARE PARTS LIST NSLH 250-210/300-250/350-310/400-390/500-500/600-630.....	43
45. ASSEMBLY DRAWING NSLV 250-210/300-250/350-310/400-390/500-500/600-630.....	44
46. NSLV 250-210/300-250/350-310/400-390/500-500/600-630	44
47. DIMENSIONAL SKETCH.....	45
48. DESMI SUBSIDIARY	46
49. SERVICE CENTER-DENMARK	47
APPENDIX A	48
APPENDIX B	49

1. PRODUCT DESCRIPTION

These operation and maintenance instructions apply to the DESMI NSLV and NSLH Monobloc pump. The NSLV pump is designed for vertical mounting (with suction flange downwards) and the NSLH pump for horizontal mounting.

The pump is a single-stage end suction centrifugal pump equipped with stainless steel shaft, mechanical shaft seal, and closed impeller.

The pump is suitable for the pumping of liquids with temperatures up to 80°C. With special shaft seal up to 100°C in Monobloc pumps with bearing (-02 design) and up to 140°C in Monobloc pumps without bearing (-12 design). For pumping of liquids with temperatures above 100°C DESMI recommends using nodular cast iron (for instance GGG40) for pump casing and rear cover. Max. working pressure and number of revolutions are indicated under Operating Data.

The pump is particularly suitable for the pumping of water in connection with cooling systems, cooling of diesel engines, as bilge pumps, ballast pumps, fire pumps, brine pumps, pumps for irrigation, fish farms, water works, district heating, salvage corps, army and navy, etc.

The descriptions in the operation and maintenance instructions are divided into three parts covering the groups **ø215/265** and **ø330/415/465/525** and **ø210/250/310/390/500/630** as the designs of these three groups are different. The numbers refer to the standard impeller diameter of the pump. E.g.:

ø215/265: Pumps with ø215 or ø265 impellers:

The back of the impeller is equipped with relief blades to reduce the load on the bearings.

ø330/415/465/525: Pumps with ø330, ø415, ø465 and ø525 impellers:

The back and the front of the impeller are equipped with sealing rings and relief holes to reduce the load on the bearings.

ø210/250/310/390/500/630: Mixed flow pumps with ø210, ø250, ø310, ø390, ø500 and ø630 impellers: The front of the impeller is equipped with sealing rings.

1.1 DELIVERY

- Check on delivery that the shipment is complete and undamaged.
- Defects and damages, if any, to be reported to the carrier and the supplier immediately in order that a claim can be advanced.

2. TECHNICAL DATA

The pumps are manufactured in various material combinations which appear from the type number on the name plate. See below.

2.1 EXPLANATION OF THE TYPE NUMBER

All the NSLV and NSLH pumps are provided with a name plate. The type number indicated on the name plate is built up as follows:

NSLVXXX-YYY/MR-Z or NSLHXXX-YYY/MR-Z

XXX: Pressure branch diameter, YYY: Nominal impeller diameter

M: The material combination of the pump.

R: The assembly combination of the pump.

Z: Other variants

M may be the following:

- A: Casing and shaft seal cover : Cast iron + cast iron alloy. Impeller and sealing rings: Bronze
- B: Casing and shaft seal cover : Cast iron + cast iron alloy. Impeller and sealing rings: Stainless.
- C: All cast iron
- D: Casing and shaft seal cover: Bronze or NiAlBz. Impeller and sealing rings: NiAlBz or stainless steel
- E: Special materials
- S: Casing, shaft seal cover, impeller and sealing rings: SAF2507 and stainless steel alloy.
- U: Nonmagnetic material

The pumps can be delivered in other material combinations according to agreement with the supplier.

R may be the following:

- 02: Monobloc, with bearing in the pump
- 07: Mounted on base plate with electric motor
- 09: Pump with bare shaft end
- 12: Monobloc, without bearing in the pump
- 13: Spacer, light bearing housing
- 14: Spacer, heavy bearing housing
- 15: Spacer, heavy bearing housing and heavy motor bracket (special motor bracket)
- 16: Compact spacer (i.e. pumps shown in this manual)

Z may be the following:

- h : PN6 flanges
- i : PN16 flanges
- j : PN25 flanges
- k : Special flange
- l : Other shaft seal
- m : BS flanges
- n : ANSI flanges
- o : Shockproof design
- p : Other design
- q : JIS flanges
- r : With inducer

Any use of the pump is to be evaluated on the basis of the materials used in the pump. In case of doubt, contact the supplier.

Pumps in material combinations A and C are primarily used for fresh water.
Pumps in material combination D and S are primarily used for seawater.

If the pumps are designed for special purposes the following is to be indicated:

Pump No. :
Pump type :
Application :
Comment :

2.2 TECHNICAL DESCRIPTION

The noise level indicated is the airborne noise including the motor. The noise depends on the motor type supplied, as the noise from the pump can be calculated as the noise level of the motor + 2dB(A). The noise level is for pumps with electric motors.

The capacity of the pump appears from the name plate on the pump. If the pump has been delivered without motor, the pump capacity is to be indicated on the plate when mounting the motor.

The permissible loads on the flanges appear from the following table. The values apply to standard pumps in bronze (Rg5) and cast iron (GG20). As to pumps in SG iron (GGG40), NiAlBz or stainless steel the values are to be increased by a factor 1.5.

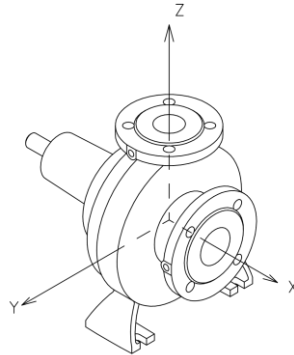

Pump size	F _y N	F _z N	F _x N	ΣF	M _y Nm	M _z Nm	M _x Nm	Σ Mt
65-215 65-265	650	840	750	1340	510	310	380	700
80-215 80-265 80-330	800	950	850	1500	550	350	400	750
100-215 100-265 100-330 100-415 100-465	1000	1250	1150	2000	650	400	500	900
125-215 125-265 125-330 125-415	1250	1600	1430	2500	830	520	650	1160
150-265 150-330 150-415 150-465	1500	1900	1700	2950	1000	650	800	1400
200-265 200-330 200-415 200-525	2000	2520	2260	3920	1330	860	1060	1860
250-210 250-330	2500	3150	2820	4900	1770	1140	1400	2470

Pump size	Fy N	Fz N	Fx N	ΣF	My Nm	Mz Nm	Mx Nm	Σ Mt
250-415 250-525	2500	3150	2820	4900	1770	1140	1400	2470
300-250 300-415 300-418 300-525	3000	3750	3350	5860	2750	1900	2200	4000
350-310 350-525	3500	4370	3920	6840	3630	2500	2930	5300
400-390	4000	5000	4480	7820	4600	3200	3700	6720
500-500	4500	5625	5040	8800	6090	4200	5040	8950
600-630	5000	6250	5600	9770	9800	6760	8100	14400

In connection with the permissible loads on the flanges the following is to be observed:

$$\left(\frac{\sum F_{calc}}{\sum F} \right)^2 + \left(\frac{\sum M_{calc}}{\sum M_t} \right)^2 < 2$$

where index "calc" is the values calculated by the user.

At the same time none of the forces or moments may exceed the indicated figure multiplied by 1.4.

3. INSTALLATION

See also: DESMI Guidelines for pump installations at:
www.desmi.com/media/sd5ltlox/guidelines_uk.pdf

3.1 MOUNTING/FASTENING

The pump should be mounted and fastened on a solid base plate or wall mounted frame so distortion is avoided. The pump should be installed so that the motor can be pulled away from the pump during maintenance work – i.e. any bolts mounted through the motor feet should be made so they are possible to remove before the motor shall be pulled away from the pump.

The max. permissible loads on the flanges stated in paragraph 2.2 are to be observed.



At installations pumping hot or very cold liquids, the operator must be aware that it is dangerous to touch the pump surface and, consequently, he must take the necessary safety measures.

3.2 WIRING



Wiring to be carried out by authorised skilled workmen according to the rules and regulations in force.

4. TRANSPORT/STORAGE

See also: DESMI Pump Storage and Preservation at: www.desmi.com/media/vgkigh54/t1534uk.pdf

The weights of the pumps in A(GG20&GGG40), D(RG5) and S(1.4436&1.4410) combination (without motor or common baseplate) are stated in the following table, and the pumps are to be lifted as shown below.

Pump size	Weight (Kg)		Pump size	Weight (Kg)	
	A/D/S-02	A/D/S-12		A/D/S-02	A/D/S-12
65-215	88/98/100	62/72/99	200-330	302/272/407	252/222/335
65-265	93/105/125	67/89/117	200-415	421/426/558	371/376/420
80-215	104/118/123	78/92/110	200-525	597/673/762	527/603/613
80-265	115/137/140	89/103/130	250-210	230/-/-	-
80-330	213/212/246	163/162/186	250-330	389/366/477	339/316/405
100-215	103/112/131	77/86/114	250-415	501/491/626	451/441/490
100-265	115/131/156	89/105/145	250-525	677/773/814	607/703/695
100-330	218/219/268	168/169/203	300-250	254/-/-	-
100-415	337/352/482	287/302/391	300-415	597/578/680	547/528/545
100-465	350/363/370	-	300-418	696/627/711	641/-/575
125-215	117/135/129	91/109/134	300-525	709/819/943	639/749/823
125-265	150/174/199	124/138/188	350-310	430/-/-	-
125-330	213/213/285	163/163/213	350-525	1060/-/-	1095/-/-
125-415	335/346/345	285/296/255	400-390	593/-/-	-
150-265	142/169/200	116/133/190	500-500	970/-/-	-
150-330	288/275/340	238/225/269	600-630	1820/-/-	-
150-415	353/360/392	303/310/299			
150-465	-/403/-	-			
200-265	247/283/260	221/247/235			

The weight of the motor is given in motor operation manual. It can be found in

- Shipping documents together with the cargo
- Shipping mark on cargo box
- Other documents for the shipment, contracts or orders, etc.

The pump is to be stored in a dry area.

Before shipment the pump is to be fastened securely on pallets or the like.

The pumps are to be lifted in the following way:

NSLV:

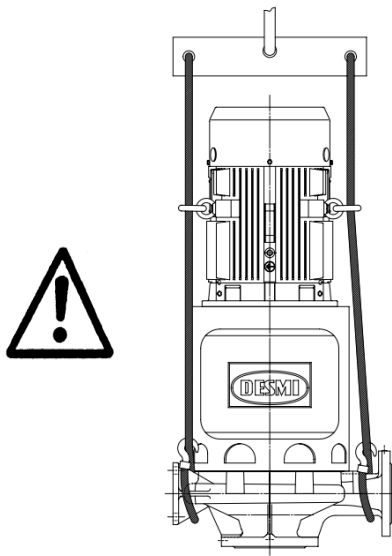

NSLH:

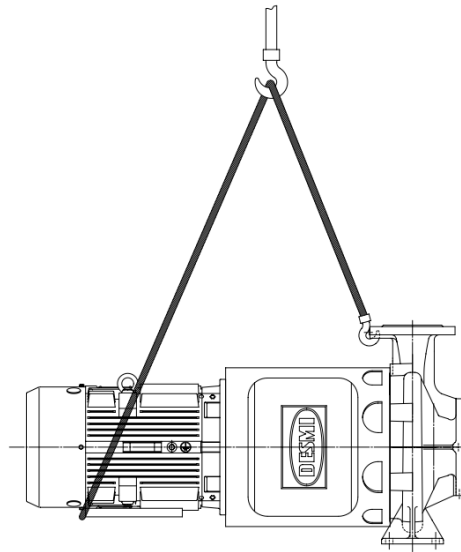

The lifting straps must not bear against sharp edges and corners.

5. DISMANTLING

5.1 ACCESS TO IMPELLER

The numbers in brackets refer to the position numbers on the assembly drawing.

ø215/265 02-combination

Remove guards (28). Remove Allen screws (22) which hold the shaft seal cover (18) and the motor bracket (20) to the pump casing (1). Dismantle copper pipe (58). Remove motor bracket and motor. Loosen shaft seal cover (18) from pump casing by means of the two M12 bolts in the threaded holes in the shaft seal cover. The shaft seal cover with shaft and impeller can now be lifted up allowing inspection of the impeller.

ø215/265 12-combination

Remove guards (28). Remove Allen screws (22) which hold the motor bracket (20) to the pump casing (1) (stainless steel pumps have separate rear cover (18) and motor bracket (20), and use Allen screw (40) to connect). Dismantle copper pipe (58). The top piece can now be lifted up allowing inspection of the impeller.

ø330/415/465/525 02-combination

Remove guards (28). Remove set screws (64) which hold the motor bracket (20) to the pump casing (1). Dismantle copper pipe (58) (for NSLV). Remove motor bracket and motor. Remove set screws (22) with washers (23), which hold the shaft seal cover (18) to the pump casing. Loosen the shaft seal cover from the pump casing by means of the pointed screws (86). The shaft seal cover with shaft and impeller can now be lifted up allowing inspection of the impeller.

ø330/415/525 12-combination

Remove guards (28). Remove set screws (64) which hold the motor bracket (20) to the pump casing (1). Dismantle copper pipe (58) (for NSLV). Remove set screws (22) with washers (23), which hold the shaft seal cover (18) to the pump casing. Loosen the shaft seal cover from the pump casing by means of the pointed screws (86). The motor and motor bracket with shaft seal cover and shaft with impeller can now be lifted up allowing inspection of the impeller.

ø210/250/310/390/500/630 02-combination

Remove guards (28). Remove set screws (64) which hold the motor bracket (20) to the pump casing (1). Dismantle copper pipe (58) (for NSLV). Remove motor bracket and motor. Remove set screws (22) with washers (23), which hold the shaft seal cover (18) to the pump casing. Loosen the shaft seal cover from the pump casing by means of the pointed screws (86). The shaft seal cover with shaft and impeller can now be lifted up allowing inspection of the impeller.

5.2 DISMANTLING SHAFT SEAL

ø215/265 02-combination

Pull the shaft seal cover off the motor bracket, by which the coupling (19) is pulled off the motor shaft. Remove nut (6). Pull off the impeller (5) and remove sunk key (9). Remove Allen screws (16), which hold the bearing cover (15) to the shaft seal cover, pull shaft seal cover and bearing cover apart, by which shaft seal (10) and water deflector (11) are pulled off the shaft.

ø215/265 12-combination

Remove nut (6). Pull off the impeller (5), and remove sunk key (9). Remove set screws (71) and pull motor bracket and electric motor with shaft (17) apart, by which the shaft seal is pulled off the shaft.

ø330/415/465/525 02-combination

Remove set screw (6). Pull off the impeller, and remove sunk key (9). Remove set screws (16), which hold the bearing cover (15) to the shaft seal cover, pull shaft seal cover and bearing cover apart, by which the shaft seal (10) is pulled off the shaft.

ø330/415/525 12-combination

Remove set screw (6). Pull off the impeller, and remove sunk key (9). Pull shaft seal cover out of motor bracket, by which the shaft seal (10) is pulled off the shaft.

ø210/250/310/390/500/630 02-combination

Remove set screw (6). Pull off the impeller, and remove sunk key (9). Remove set screws (16), which hold the bearing cover (15) to the shaft seal cover, pull shaft seal cover and bearing cover apart, by which the shaft seal (10) is pulled off the shaft.

5.3 DISMANTLING SEAT

Press out the seat from behind the shaft seal cover or motor bracket (ø215/265 in 12-combination)

5.4 DISMANTLING BEARING (ONLY 02-COMBINATION)

Before dismantling bearing, remove ring lock (12). Pull the shaft/coupling out of the bearing cover and press the bearing out of the bearing cover.

5.5 INSPECTION

When the pump has been dismantled, check the following parts for wear and damage:

- Sealing ring/impeller:

Pump Type	Impeller material	Max. clearance measured in radius/mm
-215/265/330/415/465/525	NiAlBz/CC333G	0.4-0.5
	Stainless steel	0.6-0.7
-210/250/310/390/500/630	NiAlBz/CC333G	0.6-0.7
	Stainless steel	0.8-0.9

- Shaft seal/shaft seal cover: Check the seat for flatness and cracks.
Check the rubber parts for elasticity.
- Bearings: Replace in case of wear and noise.
- Sliding bearing/shaft: Wear=max. 0.7 mm diameter difference (only for NSLV mixed flow)

5.6 DISMANTLING COUPLING (02-COMBINATION) / SHAFT (12-COMBINATION)

It is not necessary to remove the coupling in the 02-combination or the shaft in the 12-combination during normal maintenance. However, in the 12-combination the shaft must be removed when the lower bearing in the electric motor is replaced.

02-combination:

Dismantle the coupling by removing the pointed screw (73) and pull off the coupling. If the coupling is removed on the assembled pump, take care that the bearing is not damaged by pulling too hard on the coupling. If the coupling is removed after dismantling the pump, fix the shaft at the thread at the opposite shaft end, while the coupling is pulled off. The coupling might be heated to facilitate dismantling.

12-combination:

Remove pointed screws (73). Pull off the shaft. The coupling might be heated to facilitate dismantling.

6. ASSEMBLING

The type of accessories used during assembling work including oil and grease shall meet the requirement from application, food-approved if required.

6.1 TIGHTENING TORQUES

Part. No.	Thread Size (mm)	Tightening Torque (Nm)	
		Pump Casing/Rear Cover in GG20/Rg5 material	Pump Casing/Rear Cover in GGG40/NiAlBz/SS material
64	M8	8	16
	M12	27	54
	M16	65	130
22	M8	8	16
	M12	27	54
	M16	65	130
16	M12	27	54
	M16	65	130
6	M16	65	
	M20	130	
	M24	220	
71	M12	54	
	M16	130	
	M20	240	
	M24	400	

6.2 FITTING SEALING RINGS

When fitted, the sealing ring (4) has to bear against the shoulder of the pump casing.

NOTICE: For coated cast iron pump casing, seal the corner between sealing ring and pump casing with Soudal Fix All Crystal sealant

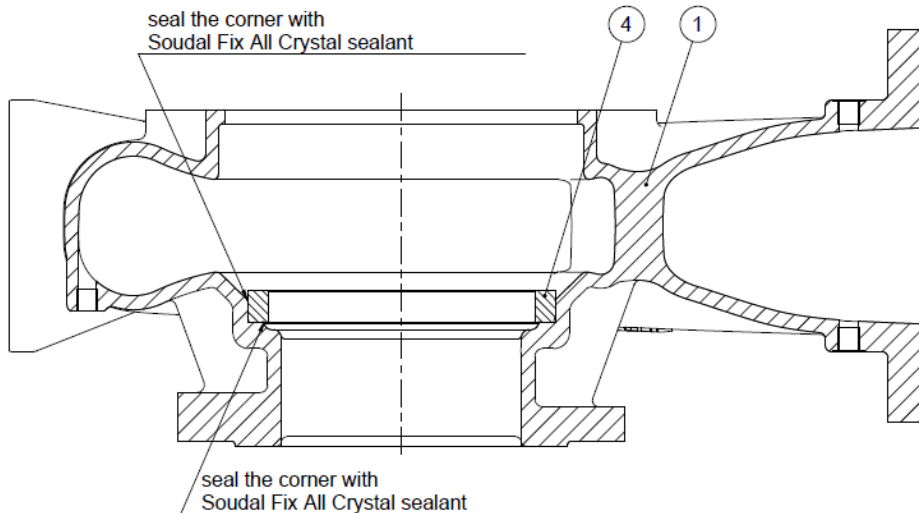

ø330/415/465/525

When fitted the sealing ring (27) has to bear against the shoulder of the shaft seal cover (20).

NOTICE: For coated cast iron shaft seal cover, seal the corner between sealing ring and shaft seal cover with Soudal Fix All Crystal sealant.

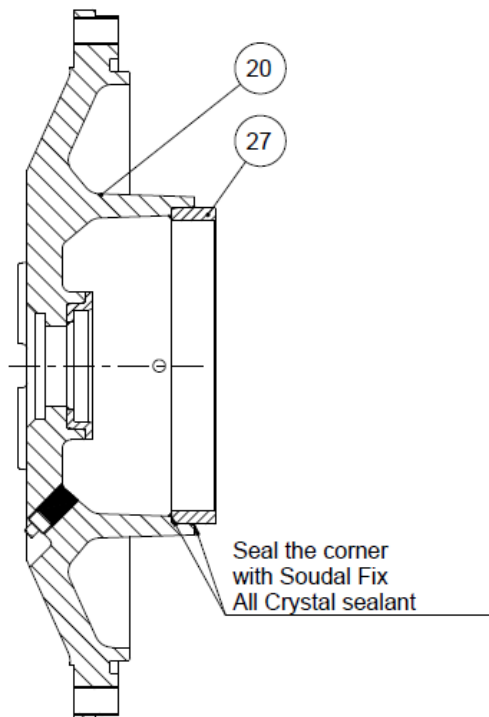

6.3 FITTING BEARING (ONLY 02-COMBINATION)

Note: Fill open and semi-open bearings with grease before assembly with bearing cover (ref. Section 11).

Place the support disc (14) (grease valve ring in $\varnothing 330/415/525$ & $\varnothing 210/250/310/390/500/630$ with angular ball bearings) in the bearing cover and press the bearing into place in the bearing cover. Lead the shaft through the bearing cover, support disc and bearing, and press the bearing into place up against the support disc. Fit ring lock (12).

$\varnothing 330/415/465/525$ & $\varnothing 210/250/310/390/500/630$

Fit cover under bearing (26). For pumps with Lip seal in cover under bearing please read appendix B.

If shim(s) are mounted between cover under bearing (26) and bearing then also mount shim(s) when bearings are replaced.

DESMI spare part numbers for 0.1 mm thick shims:

705057 (SHIM $\varnothing 110/140$), 707214 (SHIM $\varnothing 130/160$), 722876 (SHIM $\varnothing 160/190$)

6.4 FITTING WATER DEFLECTOR (ONLY 02-COMBINATION)

$\varnothing 215/265$

Assemble bearing cover and shaft seal cover. Lead the water deflector (11) over the shaft until it touches the shaft seal cover and then further 1-1.5 mm into the shaft seal cover. Do not fasten bearing cover and electric motor until motor and coupling have been mounted and the shaft can rotate freely without noise.

$\varnothing 330/415/465/525$

Lead the water deflector (11) over the shaft until it touches the cover under bearing (26) and then further 1-1.5 mm towards the cover under bearing. Assemble bearing cover and shaft seal cover. Do not fasten bearing cover and electric motor until motor and coupling have been mounted and the shaft can rotate freely without noise.

$\varnothing 210/250/310/390/500/630$

Lead the water deflector (11) over the shaft until it touches the cover under bearing (26) and then further 1-1.5 mm towards the cover under bearing. Assemble bearing cover and shaft seal cover. Do not fasten bearing cover and electric motor until motor and coupling have been mounted and the shaft can rotate freely without noise.

NOTICE: For coated shaft seal cover/rear cover with SS seat built-in, seal the corner between SS seat and shaft seal cover with Soudal Fix All Crystal sealant and smear silicon grease on outside surfaces without coating as below picture show.

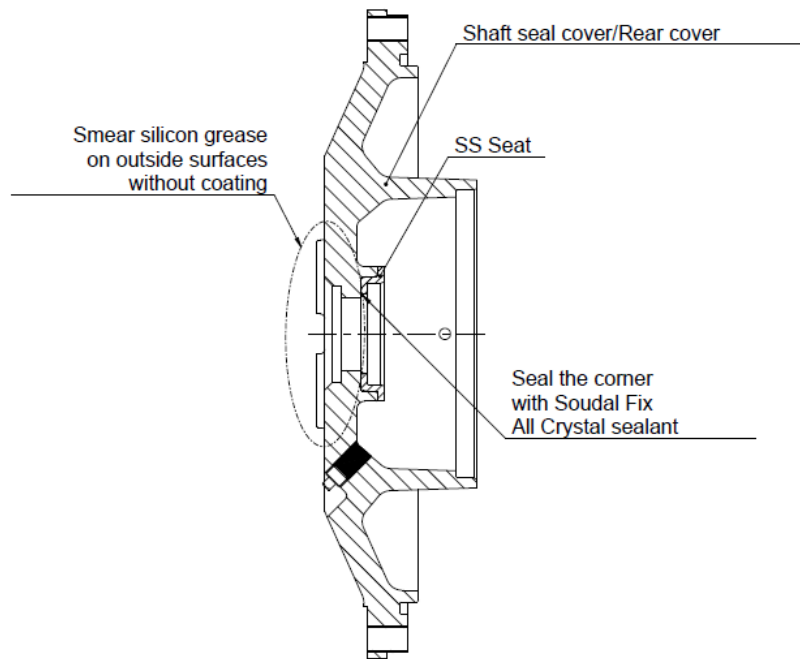

6.5 FITTING SHAFT SEAL

For pumps with balanced shaft seal type ELK (=“L” included in pump code on name plate) please read appendix A

Before fitting the seat, clean the recess in the shaft seal cover or the motor bracket ($\varnothing 215/265$ in 12-combination). When fitting the seat, remove the protective coating without scratching the lapped surface and lubricate the outer rubber L-ring of the seat with a thin layer of silicone grease. Use a brush and ensure that no silicone grease ends up at the slide surface. Now press the seat into place with the fingers and check that all parts are correctly imbedded.

If it is necessary to use tools for assembling, then protect the sliding surface of the seat to prevent it from being scratched or cut. Lubricate the inner surface of the slide ring rubber bellows with a thin layer of silicone grease (ensure that no silicone grease ends up at the slide surfaces) and push it over the shaft. The use of a conical fitting bush as shown on the assembly drawing is recommended to avoid that the rubber bellows is cut.

Push the slide ring over the shaft with the hand. If the rubber bellows is tight, use a fitting tool and take care that the slide ring is not damaged. If the carbon ring is not fixed, it is important to check that it is fitted correctly, i.e. the chamfered/lapped side is to face the seat. The carbon ring can be held by a little grease.

When using silicone grease on the shaft, the bellows will settle and seat in abt. 15 minutes, and until then tightness should not be expected. After start, check by viewing the leak hole that there are no leaks.

6.6 FITTING IMPELLER

Fit the sunk key in the shaft and lead the impeller towards the shoulder of the shaft. Take care that the ring at the end of the shaft seal spring locates in the recess of the impeller. Secure the impeller with washers (7 and 8) and a nut ($\varnothing 215/265$) or a set screw ($\varnothing 330/415/465/525$). Secure set screw (6) or nut (6) with a removable screw locking agent, e.g. Loctite 243 or Omnifit 40M. Tighten according to below table.

6.7 FITTING SHAFT SEAL COVER OR MOTOR BRACKET (12-COMBINATION)

Place the O-ring (21) between pump casing and shaft seal cover (or motor bracket in ø215/265 12 combination) in the O-ring groove and hold it with a little grease. However, check the material of the O-ring first. As standard the material is nitrile, but it might be EPDM which will be damaged by mineral grease. Use soft soap or silicone grease for EPDM. Fit and fasten shaft seal cover or motor bracket, mounted with the electric motor, in the pump casing. Screw the pointed screws (86) back into the shaft seal cover before tightening. Fit copper pipe (58).

6.8 SHAFT

When the pump has been assembled, check that the shaft rotates freely. In case the shaft has been dismantled in the 12-combination, tap the shaft towards the shaft end of the electric motor by means of a plastic hammer, and fasten the pointed screws (first the middle screw) according to the below table. Check that the wobble, measured as close to the shaft end as possible, is within the limits indicated in the table.

Motor size	Dimension Pointed screws	Torque Pointed screws	Max. wobble
100/112	M6	10 Nm	70 µm
132	M8	24 Nm	70 µm
160	M10	40 Nm	70 µm
180	M12	55 Nm	70 µm
200	M12	75 Nm	70 µm
225	M16	160 Nm	70 µm
250	M16	160 Nm	70 µm
280	M16	160 Nm	70 µm
315	M16	160 Nm	70 µm
315 / 355	M20	320 Nm	70 µm

6.9 FITTING COUPLING (ONLY 02-COMBINATION)

Fit sunk key (76). If the coupling is fitted on the assembled pump, take care that you do not damage the bearing by pressing the coupling too hard. The coupling might be heated to facilitate the fitting. If the coupling is fitted before assembling the pump, the shaft must be supported at the opposite shaft end while the coupling is pressed into place. When the coupling bears against the shoulder of the pump shaft, fit the pointed screw.

Note: Grease the motor shaft before assembly with pump coupling.



7. FROST PROTECTION

Pumps which are not in operation during frost periods are to be drained to avoid frost damage. Remove the plug (3) at the bottom to empty the pump. Alternatively, it is possible to use anti-freeze liquids in normal constructions.

8. DISMANTLING

Before dismantling the pump make sure that it has stopped. Empty the pump of liquid before it is dismantled from the piping system. If the pump has been pumping dangerous liquids you are to be aware of this and take the necessary safety measures.



If the pump has been pumping hot liquids, take great care that it is drained before it is removed from the piping system.

9. START-UP

A centrifugal pump will not function until it has been filled with liquid between the foot valve and somewhat above the impeller of the pump.



The liquid also serves as coolant for the shaft seal. In order to protect the shaft seal the pump must not run dry.

ATTENTION

For safety reasons the pump is only allowed to operate against closed discharge valve for a short time (max. 5 minutes and at a max. temperature of 80°C for standard pumps). Otherwise there is a risk of damage to the pump and, at worst, of a steam explosion. If the pump is not monitored, the installation of a safety device is recommended.

9.1 START-UP

Before starting the pump check that:

- the shaft rotates freely without jarring sounds.
- the pump casing and the suction line are filled with liquid.

Start the pump for a moment to check the direction of rotation. If the direction is correct (i.e. in the direction of the arrow) the pump may be started.

10. SYSTEM BALANCING

It is often difficult to calculate a manometric delivery head in advance. It is, however, decisively important to the quantity of liquid delivered.

A considerably smaller delivery head than expected will increase the quantity of liquid delivered, causing increased power consumption and perhaps cavitation in pump and piping. In the pump the impeller may show signs of heavy erosion caused by cavitation (corrosion) which may at times render an impeller unfit for use in a very short time. Not unusually do similar erosions occur in pipe bends and valves elsewhere in the piping system.

Therefore, after start-up, it is necessary to check either the quantity of liquid delivered or the power consumption of the pump e.g. by measuring the current intensity of the connected motor. Together with a reading of the differential pressure the quantity of water delivered can be determined against the characteristics of the pump.

Should the pump not function as intended, please proceed according to the fault-finding list. Bear in mind, though, that the pump was carefully checked and tested at the factory and that the majority of faults stem from the piping system.

FAULT	CAUSE	REMEDY
The pump has no or too low capacity	1. Wrong direction of rotation	Change direction of rotation to clockwise when viewed from shaft end (the direction of the arrow)
	2. Piping system is choked	Clean or replace the piping system
	3. The pump is choked	Clean the pump
	4. Suction line leaks	Find the leakage, repair the fault, non-return valve not submerged
	5. Pump takes air	
	6. Suction lift is too high	Check data sheet Q/H curve and NPSH or contact DESMI
	7. Pump and piping system wrongly dimensioned	As 5
The pump uses too much power	1. Counter-pressure is too low	Insert orifice plate or check valve / Contact DESMI
	2. The liquid is heavier than water	Contact DESMI
	3. Foreign body in pump	Dismantle the pump, remove the cause
	4. Electric motor is running on 2 phases	Check fuses, cable connections, and cables
The pump makes noise	1. Cavitation in pump	Suction lift is too high / Suction line wrongly dimensioned / Liquid temperature is too high

10.1 MECHANICAL SEAL FAILURE ANALYSIS

Description of possible failure	Impacts on the pump/system	Indications of failure	How to avoid
Pump settled (due to seizing sliding rings in mechanical shaft seal) due to standstill after storage	Mechanical seal failure/leaking after short time	<ol style="list-style-type: none"> 1. Initial leaking after first start up that does not stop after short time 	<ol style="list-style-type: none"> 1. Ensure correct storage of pumps 2. Preventive maintenance to be followed for long term storage 3. Rotate pump carefully by hand prior to first start up, to ensure integrity of mech. shaft seal
Pump settled (due to seizing sliding rings in mechanical shaft seal) due to standstill in system / stored with water inside for longer duration of time	Medium could change properties when standstill in pump based on the environment and type of medium	<ol style="list-style-type: none"> 1. Higher power consumption than calculated short time after startup 2. Leakage from mech. shaft seal after start up 	<ol style="list-style-type: none"> 1. Rotate the pump regularly, to avoid seizing 2. If not possible, pumps should be drained
Lack of NPSH available vs. NPSH required	Cavitation duty, creating vibration and mechanical damage	<ol style="list-style-type: none"> 1. Vibration and noise from the pump 2. Wear on impeller/seal ring, and possible leaking mec. seal 	<ol style="list-style-type: none"> 1. Make sure to have sufficient NPSHa at all times
Bad piping and fitting arrangement	Turbulent flow and vibrations in the system	<ol style="list-style-type: none"> 1. Vibration, and noises from the piping system. 2. Possible premature leakage from mec. seal 	<ol style="list-style-type: none"> 1. Check piping and fitting arrangement is in accordance with CEN standards. 2. Should be reviewed and approved in design phase

Description of possible failure	Impacts on the pump/system	Indications of failure	How to avoid
Starvation / lack of inlet flow	Pump not receiving enough liquid to give a stable operation, pump not giving sufficient flow. Could cause insufficient liquid film in seal and cause dry running	<ol style="list-style-type: none"> 1. Vibrations in the pump and unstable operational readings 2. Flow not increasing at higher pump speed. 3. Possible leaking mechanical seal 	<ol style="list-style-type: none"> 1. Make sure all valves are open, and no filters are clogged etc. 2. Check piping and fittings 3. Other consumers on the same suction line might cause problems
High liquid velocities	Vibrations and turbulent flow in the system	<ol style="list-style-type: none"> 1. Noise, vibration and lack of pump performance. 2. Possible leaking mech. shaft seal 	<ol style="list-style-type: none"> 1. Make sure to have piping dimensioned for specified flow rating 2. In general liquid velocity should increase from piping inlet through the pump to the outlet
External excited vibrations from the vessel or piping system	If above recommended levels (7mm/s) it can lead to premature mechanical failures	<ol style="list-style-type: none"> 1. Visual and measured vibration levels. 2. Leaking mech. shaft seal 	<ol style="list-style-type: none"> 1. Install vibration reducing components such as flexible bellows at inlet/outlet, vibration pads on base plate, horizontal lateral support on motor

Description of possible failure	Impacts on the pump/system	Indications of failure	How to avoid
Dry running of the pump – closed inlet/discharge valve	Pump should never be run dry, this will damage the mechanical seal in very short time, and will cause bearing failure and total pump breakdown	<ol style="list-style-type: none"> 1. Valves closed, quickly generating heat in the pump, high noises, increased power consumption before total breakdown 	<ol style="list-style-type: none"> 1. Always make sure pump is never operated dry (check regularly that any priming systems are working) and/or with closed suction valves. 2. Can operate for a short time towards shut discharge valve, refer to the chapter 9
Operating outside recommended QH area (70-120% of BEP)	Can lead to premature mechanical failure and further damage	<ol style="list-style-type: none"> 1. Readings of operational/log data. 2. At least diff. pressure, power and pump speed. Compare with design specification 	<ol style="list-style-type: none"> 1. Continuously monitoring the operation. 2. Use limitations and alarms in the control system – min/max rpm, flow, pressure
Medium and/or pressure and/or liquid temperature not according to specification	Depends on specification and actual difference in this	<ol style="list-style-type: none"> 1. Abnormal wear and corrosion in the pump. 2. Leaking mechanical seal 	<ol style="list-style-type: none"> 1. Mechanical seal material and properties are specified based on medium and conditions. 2. Difference in spec. might require a different mechanical seal / pump material

Description of possible failure	Impacts on the pump/system	Indications of failure	How to avoid
Water hammer / hydraulic shocks	Cause a tremendous pressure shock to the pump and system that could cause serious damage	<ol style="list-style-type: none"> 1. Shutting down and closing valves creates noise and give hydraulic shocks to the whole system 2. Will cause mechanical damage, not only to mechanical seals 	<ol style="list-style-type: none"> 1. Have sufficient ramp down time and avoid closing valves too fast. 2. Correct usage of non-return valves
Pump parts (e.g. vent/flush piping) in pump clogged up	Missing supply of liquid for cooling/lubrication of mechanical shaft seal and/or missing automatic air venting of shaft seal chamber	<ol style="list-style-type: none"> 1. Seal leakage after short time 	<ol style="list-style-type: none"> 1. Ensure proper filters / mesh size on suction side of pump. 2. If solids sediment inside pump parts (e.g. piping) they must be disassembled and cleaned inside regularly
Production faults from maker	Normally discovered during testing at the factory	<ol style="list-style-type: none"> 1. Seal leakage after short time 	<ol style="list-style-type: none"> 1. Hydrostatic (leakage) and performance test 3.1 or 3.2. 2. Specific classification requirement testing to exclude possibility of production faults

Troubleshooting:

For the maker to begin troubleshooting we need at least the supporting documents “letter of investigation of pump failure” and possibly “commissioning check list” to be properly filled in. We recommend retrieving information in the following order (to optimize the time usage):

1. Description of the failure and pictures of the damage together with operational readings/log data. This can eliminate or verify many of the possible failures and is the easiest and best way to begin troubleshooting.
2. If nothing can be concluded after point no. 1. pictures and description of the piping system

(especially suction piping) should be provided. Also verify if there has been any observation of excessive vibrations or noise coming from the vessel/pump/system.

3. If we cannot conclude possible root cause from information received under point 1. or 2. it might be necessary to send a service engineer to investigation and further troubleshooting.

Other considerations:

- The mechanical seal is normally not covered under warranty/guarantee, as this is considered a "wear and tear" part.
- A mechanical seal might have some initial leakage like drops or a small trickle during first start-up as it has not yet fully settled and become tight. Observe the mechanical seal to see if leakage stops, if not it could be enough to dismantle the mechanical seal and clean it properly to stop the leakage.
- Mechanical seal is the single most exposed/vulnerable part in a 1-stage centrifugal pump; hence a mechanical seal failure is often the first indication of problems. Failure can occur in only a few minutes running in the wrong conditions, so it is often difficult to find root cause of damage if we do not have complete set of information from the vessel.
- In order to avoid serious damage to pumps make sure to follow the maintenance recommendations given by the maker. Inspect the pumps regularly for initial leakage. If leakage is observed, it is important to take action to replace seal as quickly as possible.
- Check regularly that the shaft seal leak drain hole in the rear cover (or in bearing cover/bracket on some pump designs) is not clogged up. A clogged shaft seal leak hole can lead to premature bearing failure due to water rising up into the pump ball bearings when the shaft seal is worn out and/or damaged.
- We always recommend having spare mechanical seal (spare part kit) onboard the vessel at all time to avoid standstill of pumps in case of seal failure.

11. INSPECTION AND MAINTENANCE

Inspect the shaft seal for leaks at regular intervals.

- Before inspection of a pump without guard check that the pump cannot be started unintentionally.
- The system is to be without pressure and drained of liquid.
- The repairman must be familiar with the type of liquid which has been pumped as well as the safety measures he is to take when handling the liquid.

On Monobloc pumps with bearing (/ -02 design), the drain hole at the mechanical shaft seal must be inspected regularly (see drawing example below). Clean the drain hole as needed. If the drain hole clogs up, leaking liquid and/or vapors from the shaft seal can be forced up into the bearing unit, which can result in a much shorter bearing life than normal.

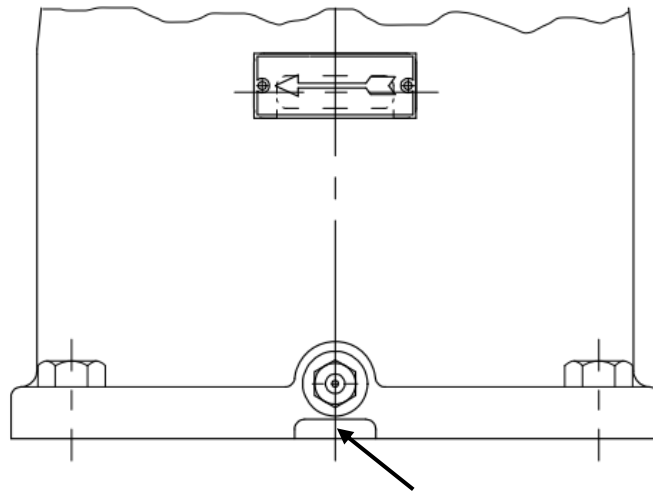

DRAIN HOLE FOR SHAFT SEAL

Recommended inspection and maintenance intervals for normal applications:

(half intervals are recommended for a new application – until required intervals can be determined for actual application)
 (if daily inspection is not done remote monitoring of pump is recommended – e.g. via temperature sensors on pump bearings)

Inspect (I) or Maintain (M) at the indicated calendar time or run time interval – whichever comes first	Daily	Weekly (only /-02 design)	Monthly	25000 running hours or 60 months
Shaft seal leakage (normally less than 0.5 mL/hour (~10 drops/hour) – if more than 5 mL/hour shaft seal replacement is recommended)	I			
Motor ampere and/or power consumption within normal range	I			
Unusual noise	I			
Unusual vibration (normally less than 2.8 mm/s from pump itself – and less than 7 mm/s incl. external excited vibrations)	I			
Pressure gauge readings to be within normal range (i.e. keep flow within 70 to 120% of BEP flow if allowed by NPSHa <> NPSHr – see note below)	I			
Unusual bearing temperatures (normally less than 85°C) (only relevant for /-02 design)		I		
Check (clean if required) drain hole for shaft seal ((only relevant for /-02 design)			I (M)	
Pumps not running: Rotate pump shaft 2 to 3 revolutions or start shortly (if pump is filled with liquid)			M	
Regrease pump and/or motor bearings (only pump bearing(s) in /-02 design)	Ref. to section 11.2 & motor manual (if motor bearings are re-greaseable)			
Replace mechanical shaft seal and V-ring (V-ring only in /-02 design)				M
Replace pump bearing(s) (only bearing(s) in /-02 design)				M

Note: Operation outside 70 to 120% of BEP flow reduce the pump life (incl. shaft seal and pump bearings) significantly.

11.1 DRAINING THE PUMP

When the piping system has been drained, note that there is still liquid in the pump. Remove the liquid by dismantling the pipe plug (3) at the bottom of the pump.

11.2 BEARING

In the 12-combination the life depends on the relubrication, size and quality of the bearing in the motor.

ø215/265 in 02-combination

The bearing in the 02-combination is dimensioned for a nominal (i.e. only obtainable for ideal greasing and operating conditions) life of 25,000 working hours. The bearing is lubricated for life and requires no attention but is to be replaced in case of noise or bearing wear.

ø330/415/465/525 in 02-combination

The bearing is dimensioned for a nominal (i.e. only obtainable for ideal greasing and operating conditions) life of 100,000 working hours and is to be relubricated according to the below table. The bearing is to be replaced in case of noise or bearing wear.

ø210/250/310/390/500/630

The bearing in the 02-combination is dimensioned for a nominal life of 25,000 working hours and is to be relubricated according to the below table . The bearing is to be replaced in case of noise or bearing wear.

Light bearing housing (single-row ball bearing)

The bearing is to be relubricated through the lubricator nipple (84) in the bearing cover (15). In connection with replacement, the bearings are to be mounted with the RS - sealing facing downwards, fill the bearing itself with grease and place a grease bead on the bearing towards the shaft in a quantity corresponding to the table below.

Heavy bearing housing (two angular ball bearings)

The bearings are to be relubricated through the lubricator nipple (84) in the bearing cover (15). Fill the bearings with grease and place a grease bead on the bearing towards the shaft in a quantity corresponding to the table below.

Pump	Assembly	Interval (running hours)	Quantity
80-330 100-330 125-330 100-415 100-465 125-415	Light bearing housing	4500 hours	30 g
250-210 300-250	Heavy bearing housing	4500 hours	35g
150-330 200-330 250-330 150-415 150-465 350-310 400-390	Heavy bearing housing	4500 hours	40 g
200-415 250-415 300-415 300-418 500-500	Heavy bearing housing	4500 hours	50 g
200-525 250-525 300-525 350-525 600-630	Heavy bearing housing	4500 hours	80 g

If the pumped liquid temperature is below 80°C the following types of grease are recommended:

ESSO	Beacon 2
BP	Energrease LS EP 2
Shell	Gadus S5 V100 2
Mobil	Mobil lux grease EP 2
Castrol	Spheerol AP 2 or AP 3
Texaco	Multifak EP 2
Q8	Rembrandt EP 2 or Rubens
Statoil	Uniway Li 62
GULF	GulfSea HYPERBAR LC3

If the pumped liquid temperature is above 80°C, high-temperature grease is recommended, e.g. SKF LGHP2.

DESMI use SKF LGHP2 as standard.

Vibration levels higher than 7 mm/s at pump bearing are considered damaging and will normally result in significantly shorter grease and/or bearing life – especially for pumps not running. Hence shorter re-greasing intervals might be required for pumps installed where external excited vibration levels can be higher than 7 mm/s.

Note that relubrication can cause a (usually temporary) bearing temperature rise of up to approx. 20 ° C - especially by mixing different types of grease and / or by overlubricating the bearing.

Grease used for relubrication must be compatible with the grease in the bearing unit.

12. REPAIRS

12.1 ORDERING SPARE PARTS

When ordering spare parts please always state pump type, serial No. (appears on the name plate of the pump), position No. on the assembly drawing and designation on the spare parts list.

Spare parts or Spare Parts Kit (SPK) can be ordered via spareparts@desmi.com

Recommended spare parts stock for 2 years' operation to DIN 24296.

13. OPERATING DATA

13.1 ALLOWED MAXIMUM MOTOR FRAME SIZE

Pump size	Pump Structure	Motor range
ø215/210	02 combination	≤225
ø215	12 combination	≤180
ø250/310	02 combination	≤250
ø265	02 combination	≤280
ø265	12 combination	≤200
ø330	02, 12 combination	≤315

Pump size	Pump Structure	Motor range
ø390	02 combination	≤315
ø415/418/465	02, 12 combination	≤355
ø500	02 combination	≤355
ø525	02, 12 combination	≤450
ø630	02 combination	≤400

13.2 MAXIMUM WORKING PRESSURE

The following working pressures (pressure in piping incl. the pressure increase caused by the pump), number of revolutions and electric motors are allowed in standard pumps:

Pump size	Max. working pressure [bar] Bronze / Cast iron	Max. working pressure [bar] SG-iron	Max. RPM 12- & 02-Combination	Pump size	Max. working pressure [bar] Bronze / Cast iron	Max. working pressure [bar] SG-iron	Max. RPM 12- & 02-Combination
65-215	16	25	3600	200-330	7 / 13	25	1800
65-265	14.5	25	3600	200-415	9 / 13	25	1800
80-215	13	25	3600	200-525	14	25	1800
80-265	14.5	25	3600	250-210	-/3.5	5	2500
80-330	15 / 15	25	3600	250-330	7 / 12	25	1800
100-215	12.5	25	3600	250-415	9 / 12	25	1800
100-265	14.5	25	3600	250-525	14	25	1800
100-330	11 / 14	25	3000	300-250	-/3.5	5	2100
100-415	10 / 12.5	25	1800	300-415	9 / 12	25	1800
100-465	8	25	1800	300-418	6/16	25	1800/1600
125-215	8	25	1800	300-525	14	25	1800
125-265	7	25	1800	350-310	-/3.5	5	1750
125-330	11 / 12	25	1800	350-525	-/16	25	1600
125-415	9 / 13	25	1800	400-390	-/4	5	1350
150-265	10	25	1800	500-500	-/3.3	6	1000
150-330	7 / 13	25	1800	600-630	-/4	5	750
150-415	9 / 13	25	1800				
150-465	9	-	1800				
200-265	10 / 12.5	25	1800				

Notice: Some pump combinations allow higher speeds than stated in the table—see actual pump name plate. The max. working pressure for NiAlBz and stainless steel pumps is 1.5 times max. working pressure for bronze (RG5).

The above-mentioned max. working pressure is a design value – delivered pumps are pressure tested according to actual application requirements and actual flange standards. For instance, the above-mentioned max. working pressure is **NOT** valid for pumps approved by a classification society. Pumps approved by classification societies have been pressure tested according to the requirements of these societies, i.e. a test pressure of 1.5 x the permissible working pressure. The

test pressure is stated in the test certificate and stamped into the discharge flange of the pump.

14. EU & UK DECLARATION OF CONFORMITY

DESMI PUMPING TECHNOLOGY A/S, hereby declare that our pumps of the NSLV and NSLH Monobloc type are manufactured in conformity with the following essential safety and health requirements in the COUNCIL DIRECTIVE 2006/42/EC on machines, Annex 1.

The following harmonized standards have been used:

EN/ISO 13857:2019	Safety of machinery. Safety distances to prevent danger zones being reached by the upper limbs
EN 809:1998 + A1:2009	Pumps and pump units for liquids – Common safety requirements
EN12162:2001+A1:2009	Liquid pumps – Safety requirements – Procedure for hydrostatic testing
EN 60204-1:2018	Safety of machinery – Electrical equipment of machines (item 4, General requirements)
Ecodesign Directive (2009/125/EC).	Water pumps: Commission Regulation No 547/2012. Applies only to water pumps marked with the minimum efficiency index MEI. See pump nameplate.
Directive 2014/34/EU	Equipment and protective systems intended for use in potentially explosive atmospheres. Applies only to pumps marked with Ex. See pump nameplate

Pumps delivered by us connected with prime movers are CE-marked and comply with the above requirements.

Pumps delivered by us without prime movers (as partly completed machinery) must only be used when the prime mover and the connection between prime mover and pump comply with the above requirements.

Nørresundby, September 20 2024



Henrik Mørkholt Sørensen
Managing Director

DESMI Pumping Technology A/S
Tagholm 1
9400 Nørresundby

15. ATEX DECLARATION OF CONFORMITY

15.1 PRODUCT DESCRIPTION

The precautions to be taken using the pumps in areas where the ATEX rules for “Ex II 2G Ex h IIb T4 Gb X” marked equipment apply. Only pumps mounted with EX-marked nameplate from DESMI are approved for / allowed to be used in EX areas.

The pumps have been examined according to EN80079-36:2016 and EN80079-37:2016. Constructional safety “c” and an Ignition Hazard Assessment has been made. As a result of this assessment the following precautions are to be taken.

15.2 PRECAUTIONS



Dry run is not allowed. Fill pump with liquid before start up. A $\cos \varphi$ measuring device can be fitted to the power circuit and set to trip the drive power in case of the power consumption being too low. The liquid in the pump also serves as coolant for the shaft seal. Dry run will result in frictional heat being developed causing critical high temperatures at seal faces.



Pumping against closed outlet valve is not allowed for more than 2 minutes. A pressure switch can be fitted to trip the drive power in case of the outlet pressure being too high.



Choking or clogging of the pump can result in either too low load or overload of the motor - or bending of the shaft. Use a strainer / filter in the suction pipe. A $\cos \varphi$ measuring device can be fitted to the power circuit and set to trip the drive power in case of power consumption being too low or too high. The thermistors (if any) in the electric motor can only be used to trip the drive power at overload.



User must replenish grease according to instruction manuals and replace bearings after 90% of rated life i.e. 22.500 hours. The bearing housing is fitted with a temperature sensor (or two in Spacer pumps) to be connected to the electrical control system on site. Set the system to trip the drive power 10°C above normal operating temperature.



Max. allowed liquid temperature is 80°C for fresh water and most likely less for other liquids. The pump housing can be fitted with a temperature sensor to be connected to the electrical control system on site and then set this to trip the drive power 10°C above normal operating temperature. Contact DESMI in case of doubt about max. allowed liquid temperature.

Nørresundby, September 20 2024

Henrik Mørkholt Sørensen
Managing Director

DESMI Pumping Technology A/S
Tagholm 1, 9400 Nørresundby

16. INFORMATION RELEVANT FOR DISASSEMBLY OR DISPOSAL AT END-OF-LIFE

No damage materials are used in DESMI pumps – please refer to DESMI Green Passport (can be sent on request – contact a DESMI sales office) – i.e. common recycling companies can handle the disposal at end-of-life. Alternatively the pump and motor can be returned to DESMI at end-of-life for safe recycling.

17. ASSEMBLY DRAWING $\varnothing 215/265/02$ -COMB

18. SPARE PARTS LIST $\varnothing 215/265$

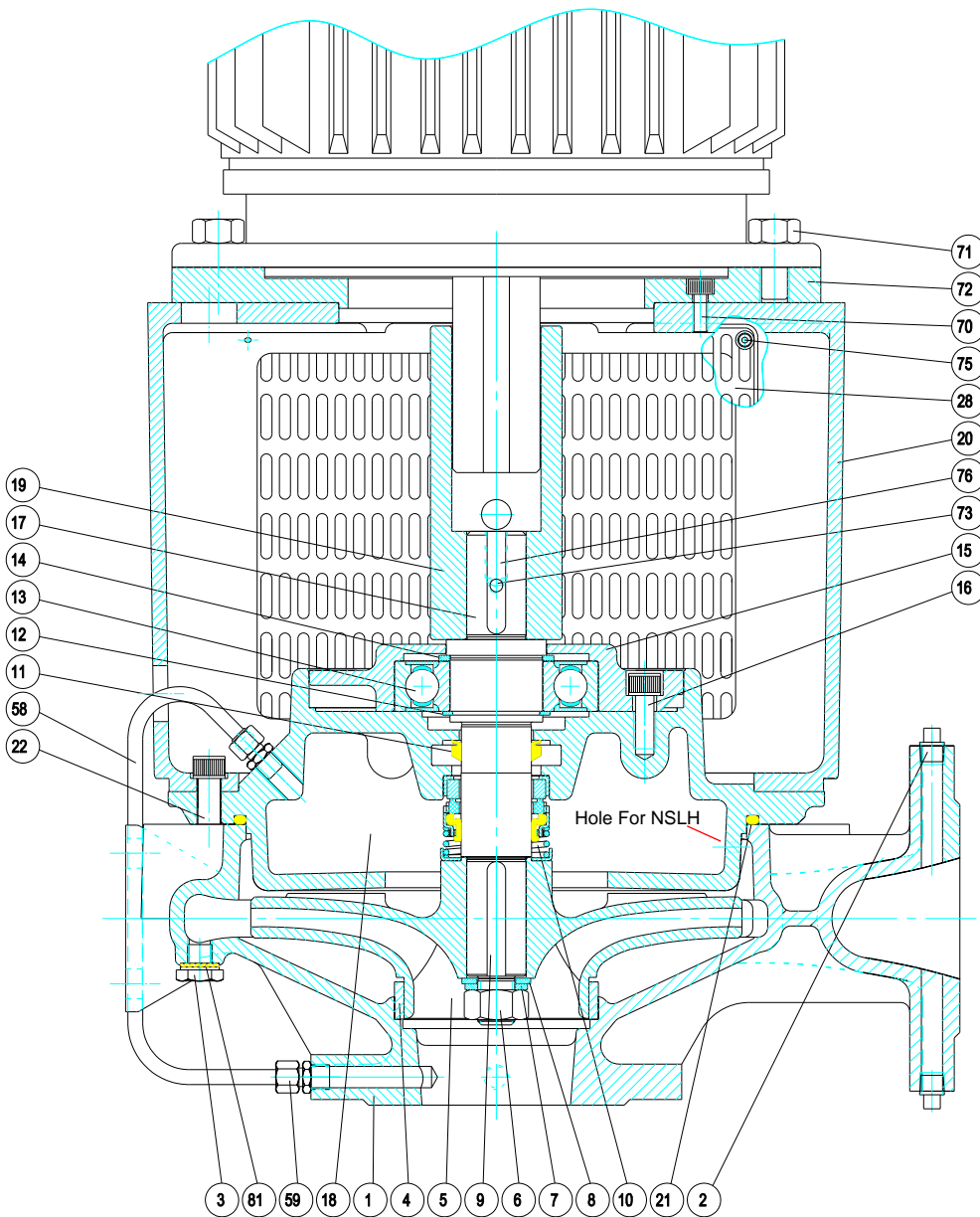

- 1 Pump casing
- 2 Pipe plug
- 3 Pipe plug
- 4 Sealing ring
- 5 Impeller
- 6 Nut
- 7 Spring washer
- 8 Washer
- 9 Sunk key
- 10 Shaft seal
- 11 Water deflector
- 12 Ring lock
- 13 Ball bearing
- 14 Support disc
- 15 Bearing cover
- 16 Allen screw
- 17 Shaft
- 18 Shaft seal cover
- 19 Coupling
- 20 Motor bracket
- 21 O-ring
- 22 Allen screw
- 28 Guard
- 58 Pipe (For NSLV)
- 59 Hexagon nipple
- 70 Allen screw
- 71 Set screw
- 72 Intermediate flange
- 73 Point screw
- 75 INSEX-screw
- 76 Sunk key
- 81 Sealing washer
- 96 Manometer
- 97 Nipple
- 98 Sleeve
- 106 Valve (optional)

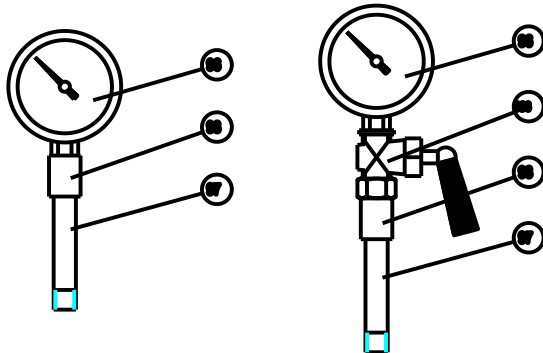

19. ASSEMBLY DRAWING $\varnothing 330/415/465/525$ 02-COMB

20. SPARE PARTS LIST $\varnothing 330/415/465/525$ WITH HEAVY BEARING HOUSING

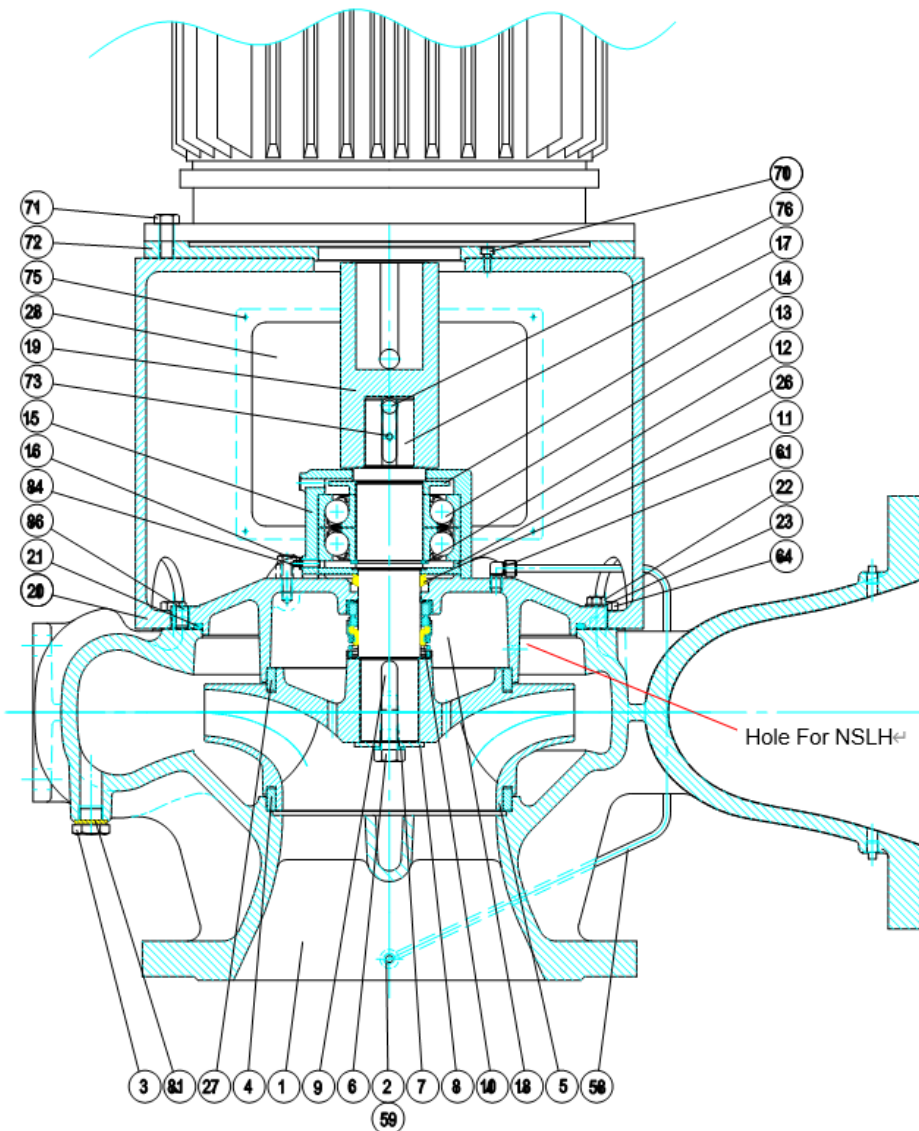

- 1 Pump casing
 - 2 Pipe plug
 - 3 Pipe plug
 - 4 Sealing ring
 - 5 Impeller
 - 6 Set screw
 - 7 Spring washer
 - 8 Washer
 - 9 Sunk key
 - 10 Mech. shaft seal
 - 11 Water deflector
 - 12 Ring lock
 - 13 Ball bearing
 - 14 Grease valve ring*
 - 15 Bearing cover
 - 16 Set screw
 - 17 Shaft
 - 18 Shaft seal cover
 - 19 Coupling
 - 20 Motor bracket
 - 21 O-ring
 - 22 Set screw
 - 23 Lock washer
 - 26 Cover under bearing*
 - 27 Sealing ring 2
 - 28 Guard
 - 58 Pipe (For NSLV)
 - 59 Hexagon nipple
 - 61 Hexagon nipple
 - 64 Set screw
 - 70 Allen screw
 - 71 Set screw
 - 72 Intermediate flange
 - 73 Point screw
 - 75 INSEX-screw
 - 76 Sunk key
 - 81 Sealing washer
 - 84 Lubricator nipple
 - 86 Point screw
 - 96 Manometer
 - 97 Nipple
 - 98 Sleeve
 - 106 Valve (optional)
- *) Option -See Appendix B

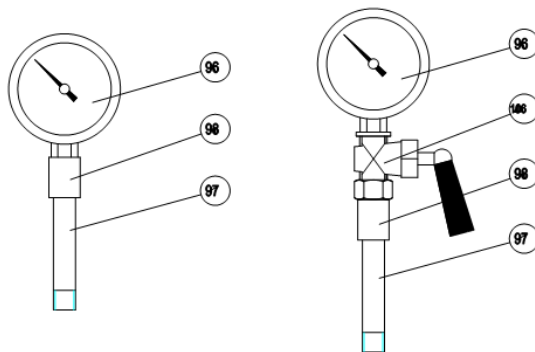

It is better to replacement motor in vertical direction for big motor in order to mount motor easy and ensure better alignment.

21. ASSEMBLY DRAWING 300-418 02-COMB.

22. SPARE PARTS LIST 300-418 02-COMB.

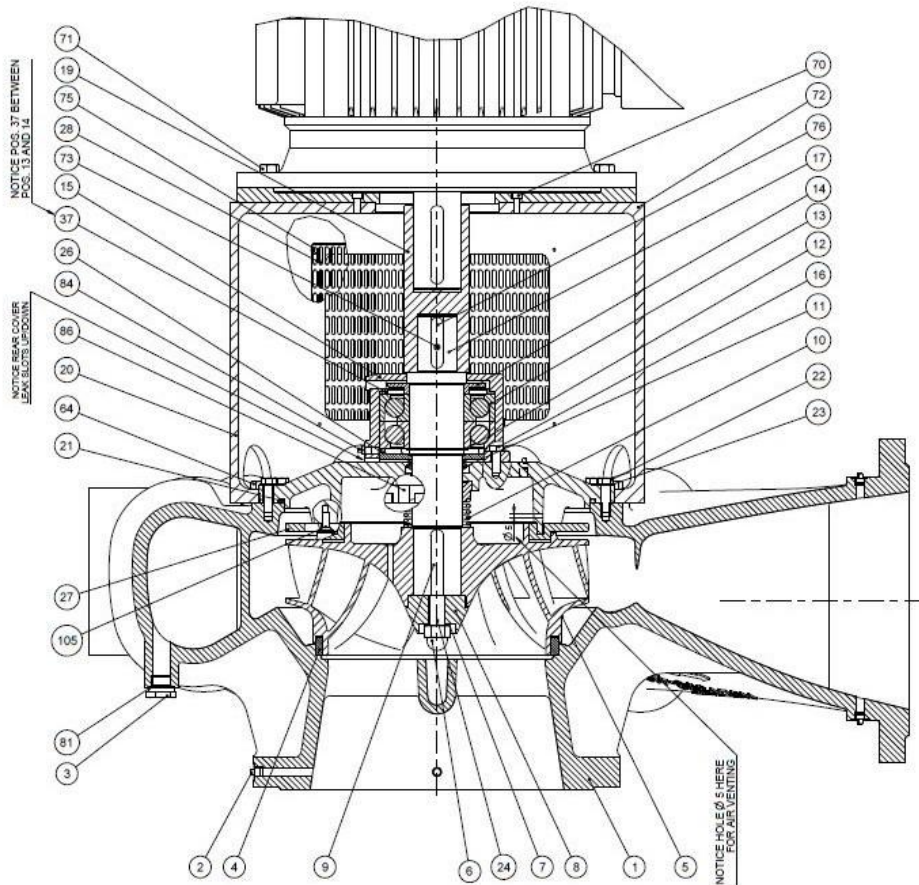

- 1 Pump casing
 - 2 Pipe plug
 - 3 Pipe plug
 - 4 Sealing ring
 - 5 Impeller
 - 6 Cap screw
 - 7 Spring washer
 - 8 Inlet cone
 - 9 Sunk key
 - 10 Mech. shaft seal
 - 11 Water deflector
 - 12 Ring lock
 - 13 Ball bearing
 - 14 Grease valve ring
 - 15 Bearing cover
 - 16 Set screw
 - 17 Shaft
 - 18 Shaft seal cover
 - 19 Coupling
 - 20 Motor bracket
 - 21 O-ring
 - 22 Set screw
 - 23 Lock washer
 - 26 Cover under bearing*
 - 27 Sealing ring 2
 - 28 Guard
 - 58 Pipe (For NSLV)
 - 59 Hexagon nipple
 - 61 Hexagon nipple
 - 64 Set screw
 - 70 Allen screw
 - 71 Set screw
 - 72 Intermediate flange
 - 73 Point screw
 - 75 INSEX-screw
 - 76 Sunk key
 - 81 Sealing washer
 - 84 Lubricator nipple
 - 86 Pointed screw
- *) Option -See Appendix B

It is better to replacement motor in vertical direction for big motor in order to mount motor easy and ensure better alignment.

23. ASSEMBLY DRAWING $\varnothing 215/265$ 12-COMB.

24. SPARE PARTS LIST $\varnothing 215/265$ 12-COMB.

See stainless steel pump on the next pages

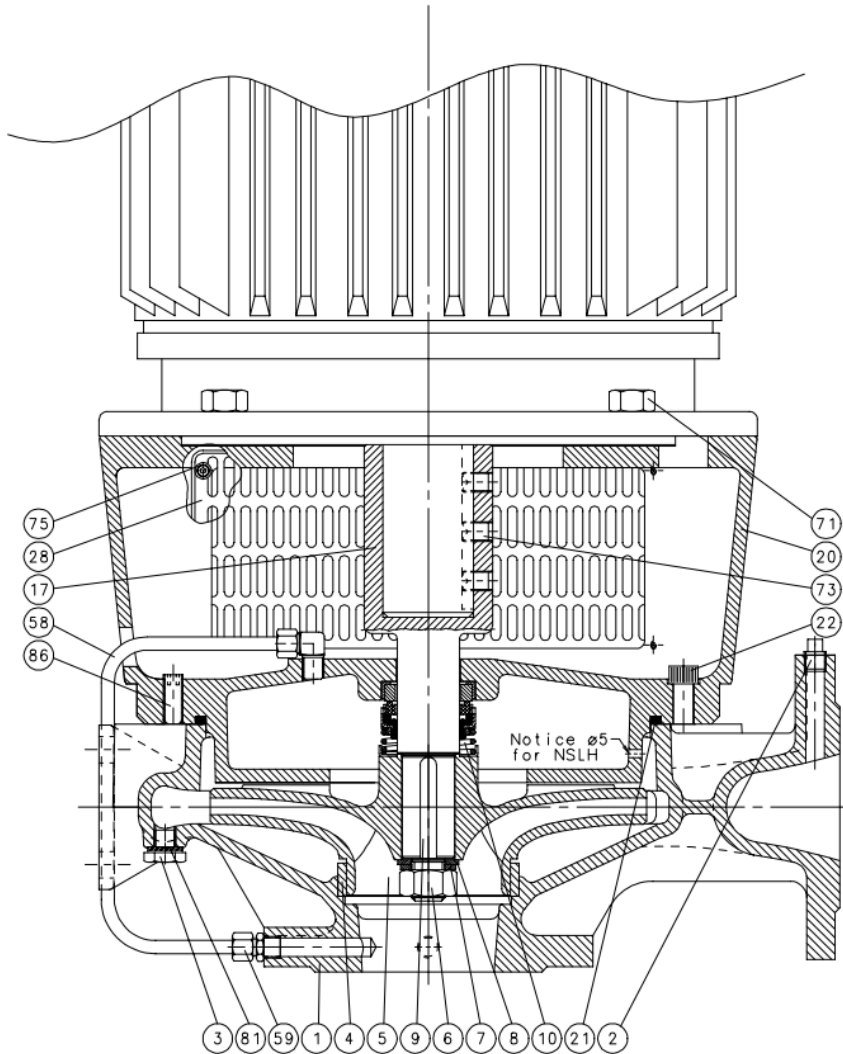

- 1 Pump casing
- 2 Pipe plug
- 3 Pipe plug
- 4 Sealing ring
- 5 Impeller
- 6 Nut
- 7 Spring washer
- 8 Washer
- 9 Sunk key
- 10 Mech. shaft seal
- 17 Shaft
- 20 Motor bracket
- 21 O-ring
- 22 Allen screw
- 28 Guard
- 58 Pipe (for NSLV)
- 59 Hexagon nipple
- 71 Set screw
- 73 Point screw
- 75 INSEX-screw
- 81 Sealing washer

25. ASSEMBLY DRAWING STAINLESS STEEL PUMP Ø215/265 12-COMB.

26. SPARE PARTS LIST STAINLESS STEEL PUMP Ø215/265 12-COMB.

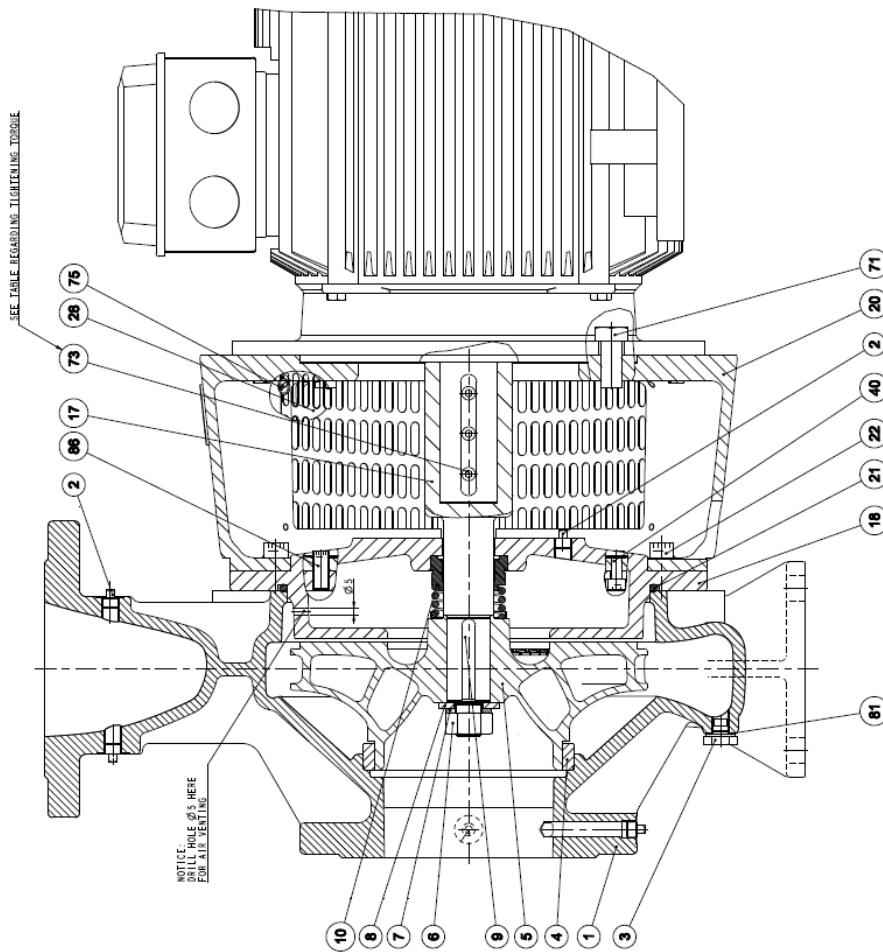

- 1 Pump casing
- 2 Pipe plug
- 3 Pipe plug
- 4 Sealing ring
- 5 Impeller
- 6 Nut
- 7 Spring washer
- 8 Washer
- 9 Sunk key
- 10 Mech. shaft seal
- 17 Shaft
- 18 Rear cover
- 20 Motor bracket
- 21 O-ring
- 22 Allen screw
- 28 Guard
- 40 Allen screw
- 58 Pipe (for NSLV)
- 59 Hexagon nipple
- 71 Set screw
- 73 Point screw
- 75 INSEX-screw
- 81 Sealing washer
- 86 Point screw

27. ASSEMBLY DRAWING $\varnothing 330/415/525$ 12-COMB.

28. SPARE PARTS LIST $\varnothing 330/415/525$ 12-COMB.

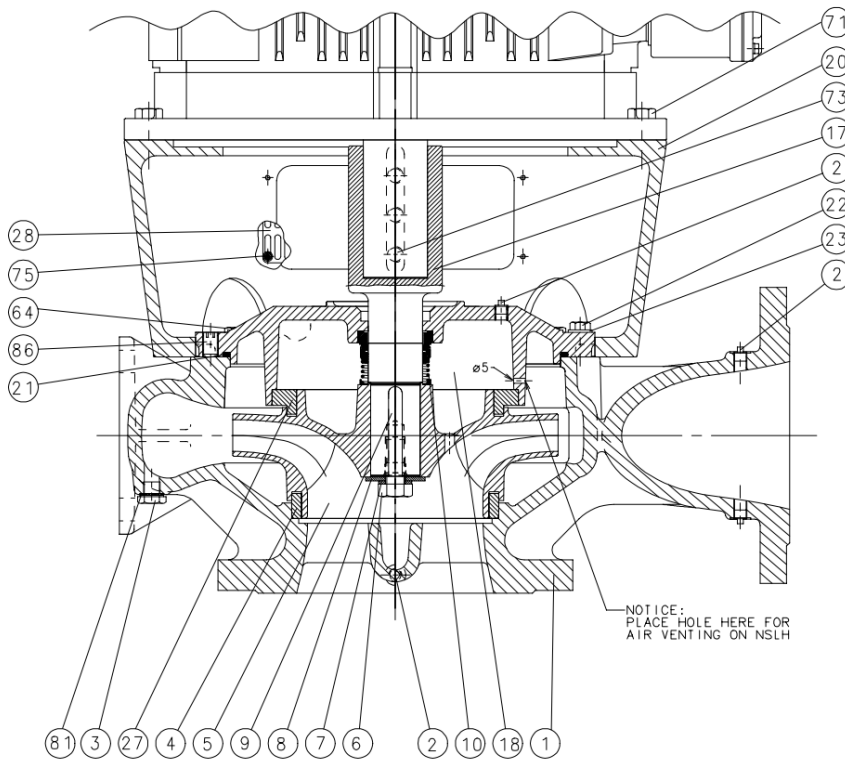

- 1 Pump casing
- 2 Pipe plug
- 3 Pipe plug
- 4 Sealing ring
- 5 Impeller
- 6 Set screw
- 7 Spring washer
- 8 Washer
- 9 Sunk key
- 10 Mech. shaft seal
- 17 Shaft
- 18 Rear cover
- 20 Motor bracket
- 21 O-ring
- 22 Allen screw
- 28 Guard
- 64 Set screw
- 71 Set screw
- 73 Point screw
- 75 INSEX-screw
- 81 Sealing washer
- 86 Point screw

29. ASSEMBLY DRAWING 300-418 AND 350-525 12-COMB.

30. SPARE PARTS LIST 300-418 AND 350-525 12-COMB.

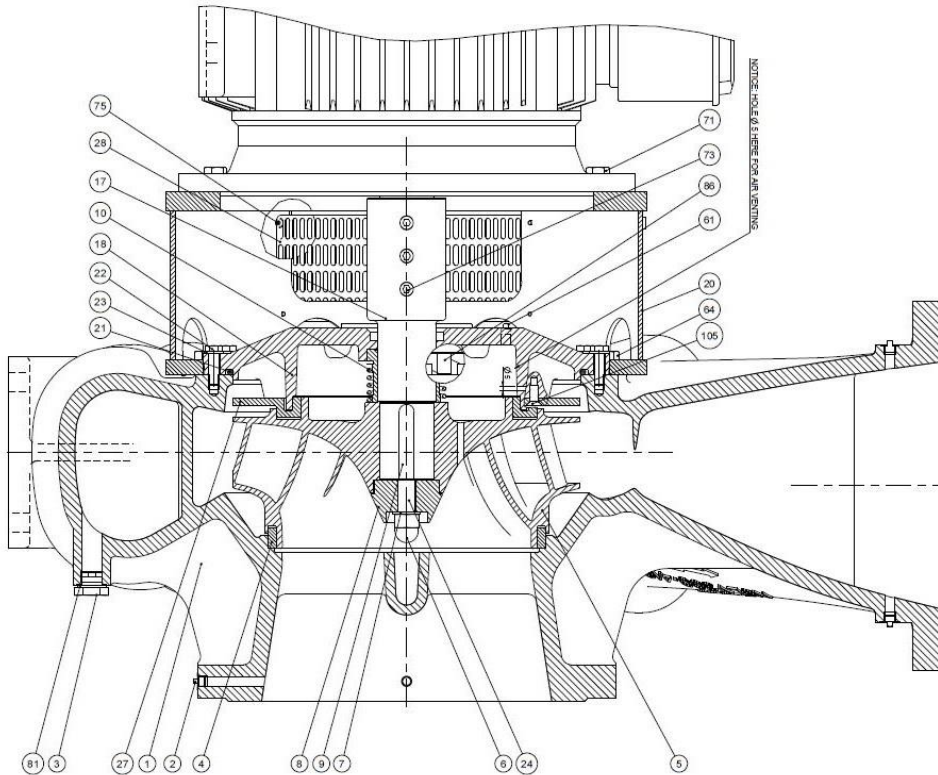

- 1 Pump casing
- 2 Pipe plug
- 3 Pipe plug
- 4 Sealing ring
- 5 Impeller
- 6 Cap nut
- 7 Spring washer
- 8 Inlet cone
- 9 Sunk key
- 10 Mech. shaft seal
- 17 Shaft
- 18 Rear cover
- 20 Motor bracket
- 21 O-ring
- 22 Set screw
- 23 Washer
- 24 Stud
- 27 Seal ring 2
- 28 Guard
- 61 Plug
- 64 Set screw
- 71 Set screw
- 73 Point screw
- 75 INSEX-screw
- 81 Sealing washer
- 86 Point screw

31. ASSEMBLY DRAWING 65-265/-02 WITH INDUCER.

32. SPARE PARTS LIST 65-265/-02 WITH INDUCER.

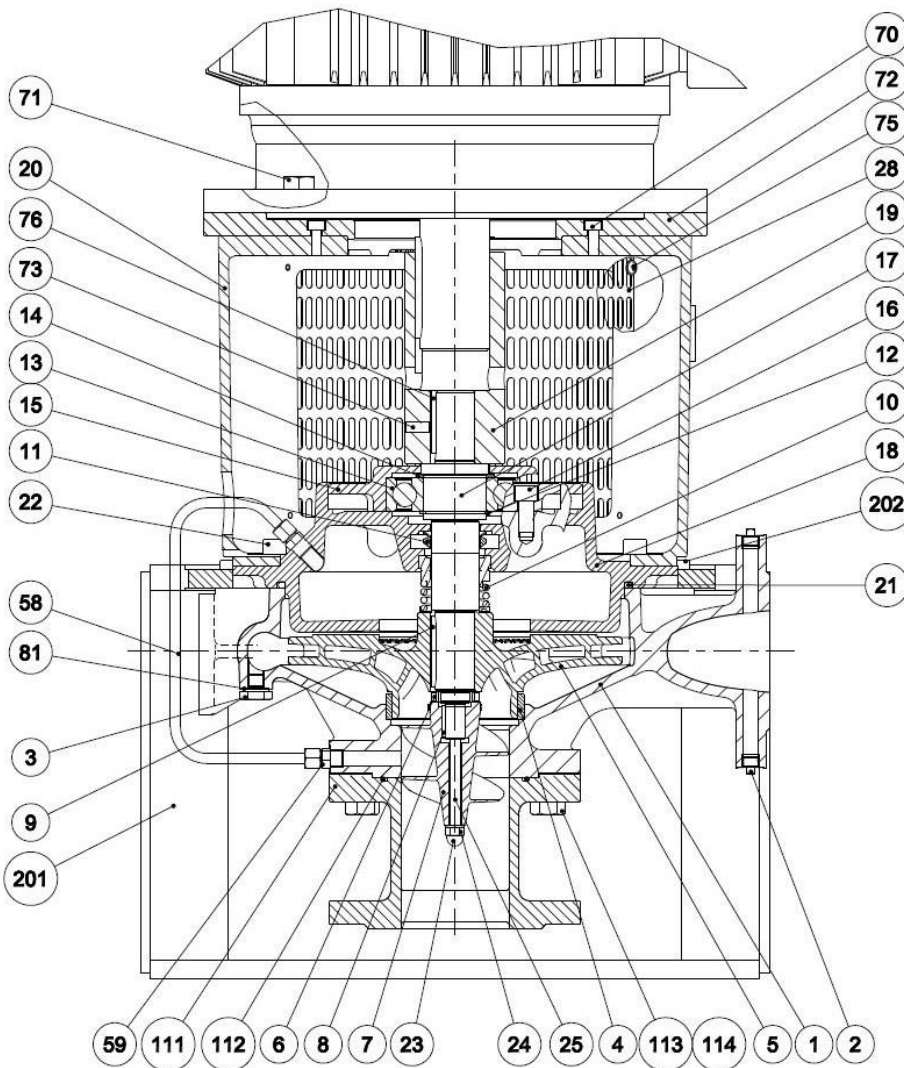

- | | |
|-----|---------------------|
| 1 | Pump casing |
| 2 | Pipe plug |
| 3 | Pipe plug |
| 4 | Sealing ring |
| 5 | Impeller |
| 6 | Small round nut |
| 7 | Inducer |
| 8 | Key |
| 9 | Sunk key |
| 10 | Mech. shaft seal |
| 11 | Water deflector |
| 12 | Ring lock |
| 13 | Ball bearing |
| 14 | Support disc |
| 15 | Bearing cover |
| 16 | Set screw |
| 17 | Shaft |
| 18 | Rear cover |
| 19 | Coupling |
| 20 | Motor bracket |
| 21 | O-ring |
| 22 | Set screw |
| 23 | Cap nut |
| 24 | Spring washer |
| 25 | Stud |
| 28 | Guard |
| 58 | Pipe |
| 59 | Hexagon nipple |
| 70 | Allen screw |
| 71 | Set screw |
| 72 | Intermediate flange |
| 73 | Pointed screw |
| 75 | INSEX-screw |
| 76 | Sunk key |
| 81 | Sealing washer |
| 111 | Inducer pipe |
| 112 | O-ring |
| 113 | Set screw |
| 114 | Nut |
| 201 | Base frame |
| 202 | Alan screw |

33. ASSEMBLY DRAWING 100-265/-02 WITH INDUCER.

34. SPARE PARTS LIST 100-265/-02 WITH INDUCER.

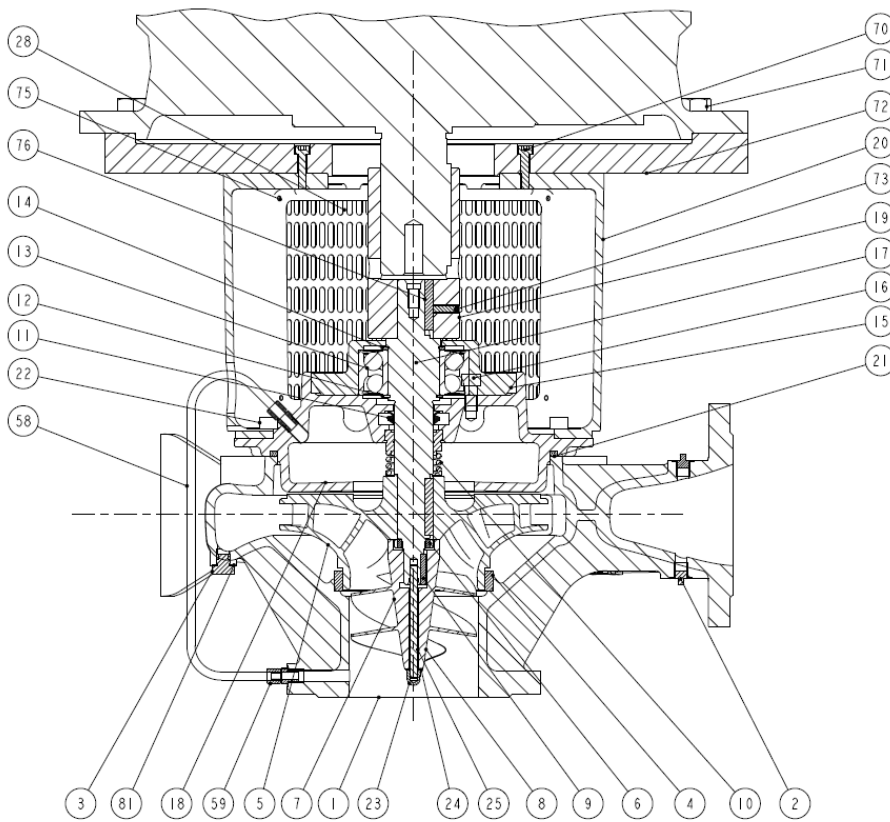

- 1 Pump casing
- 2 Pipe plug
- 3 Pipe plug
- 4 Sealing ring
- 5 Impeller
- 6 Small round nut
- 7 Inducer
- 8 Key
- 9 Sunk key
- 10 Mech. shaft seal
- 11 Water deflector
- 12 Ring lock
- 13 Ball bearing
- 14 Support disc
- 15 Bearing cover
- 16 Set screw
- 17 Shaft
- 18 Rear cover
- 19 Coupling
- 20 Motor bracket
- 21 O-ring
- 22 Set screw
- 23 Cap nut
- 24 Spring washer
- 25 Stud
- 28 Guard
- 58 Pipe (For NSLV)
- 59 Hexagon nipple
- 70 Allen screw
- 71 Set screw
- 72 Intermediate flange
- 73 Point screw
- 75 INSEX-screw
- 76 Sunk key
- 81 Sealing washer

35. ASSEMBLY DRAWING 100-330/-02 AND 100-465/-02 WITH INDUCER.

36. SPARE PARTS LIST 100-330/-02 AND 100-465/-02 WITH INDUCER.

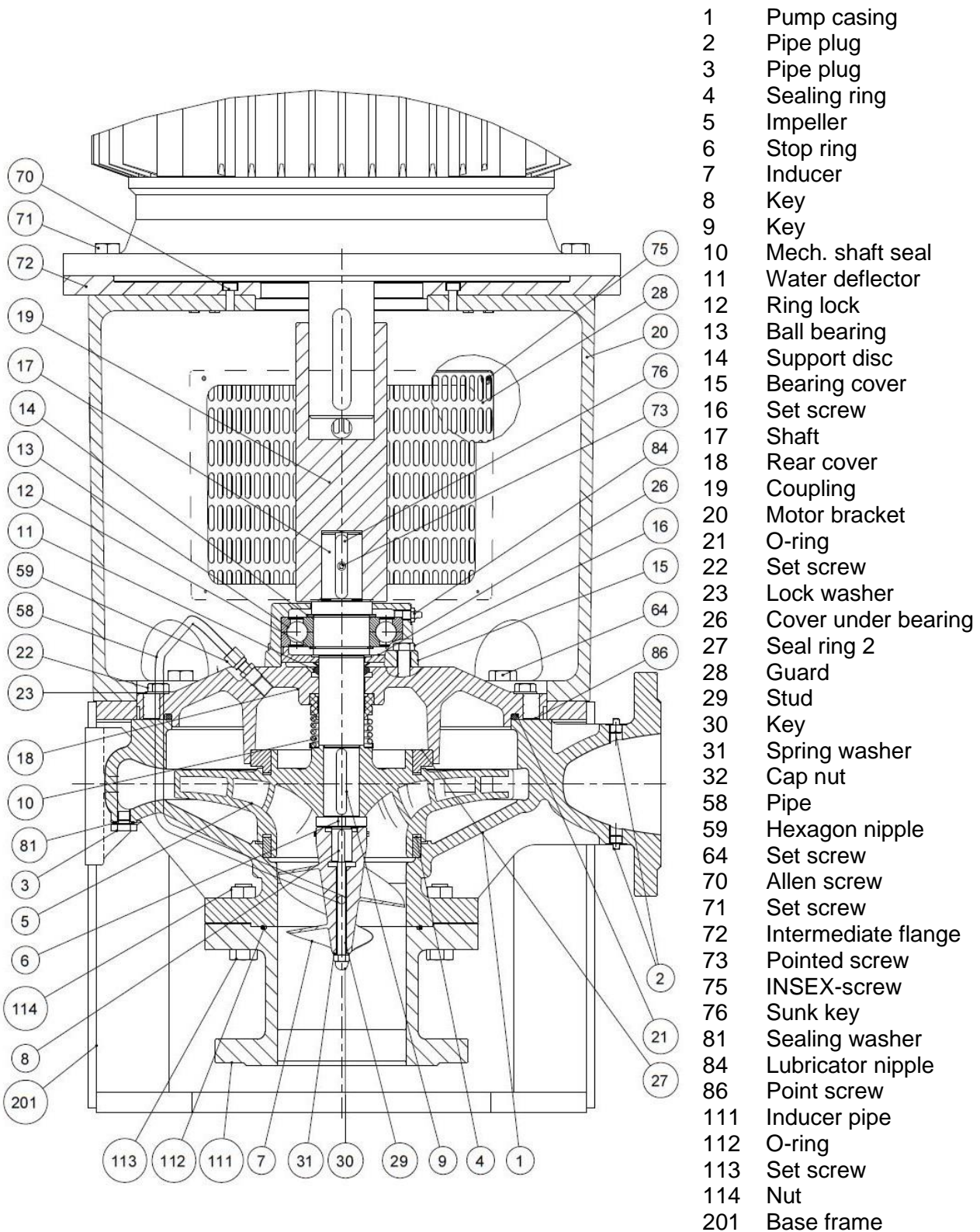

37. ASSEMBLY DRAWING 125-330/-02 WITH INDUCER.

38. SPARE PARTS LIST 125-330/-02 WITH INDUCER.

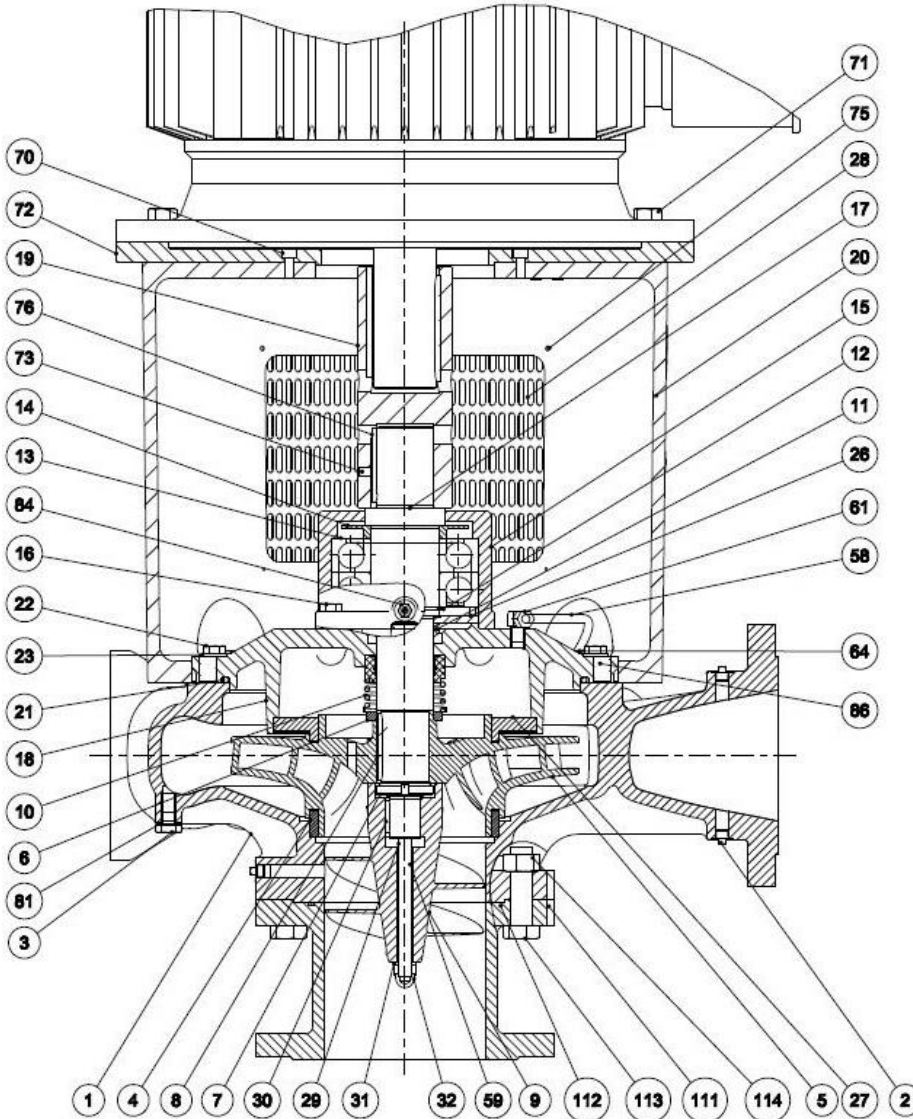

- | | |
|-----|---------------------|
| 1 | Pump casing |
| 2 | Pipe plug |
| 3 | Pipe plug |
| 4 | Sealing ring |
| 5 | Impeller |
| 6 | Stop ring |
| 7 | Small round nut |
| 8 | Key |
| 9 | Inducer |
| 10 | Mech. shaft seal |
| 11 | Water deflector |
| 12 | Ring lock |
| 13 | Ball bearing |
| 14 | Support disc |
| 15 | Bearing cover |
| 16 | Set screw |
| 17 | Shaft |
| 18 | Rear cover |
| 19 | Coupling |
| 20 | Motor bracket |
| 21 | O-ring |
| 22 | Set screw |
| 23 | Lock washer |
| 26 | Cover under bearing |
| 27 | Seal ring 2 |
| 28 | Guard |
| 29 | Stud |
| 30 | Key |
| 31 | Spring washer |
| 32 | Cap nut |
| 58 | Pipe |
| 61 | Hexagon nipple |
| 64 | Set screw |
| 70 | Allen screw |
| 71 | Set screw |
| 72 | Intermediate flange |
| 73 | Pointed screw |
| 75 | INSEX-screw |
| 76 | Sunk key |
| 81 | Sealing washer |
| 84 | Lubricator nipple |
| 86 | Point screw |
| 111 | Inducer pipe |
| 112 | O-ring |
| 113 | Set screw |
| 114 | Nut |

39.ASSEMBLY DRAWING 150-465/-02 WITH INDUCER.

40. SPARE PARTS LIST 150-465/-02 WITH INDUCER

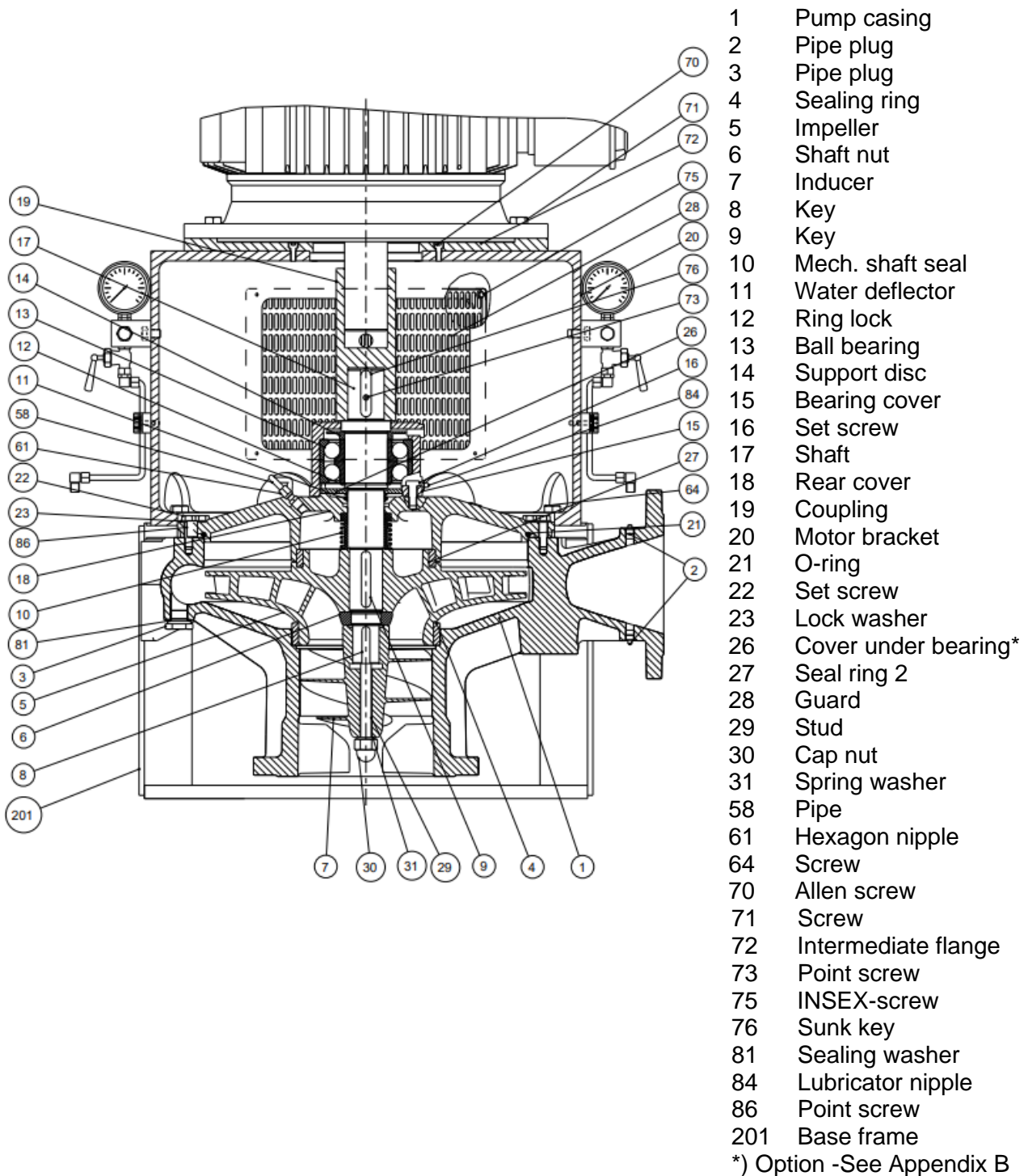

41. ASSEMBLY DRAWING 300-415/-02 WITH INDUCER.

42. SPARE PARTS LIST 300-415/-02 WITH INDUCER

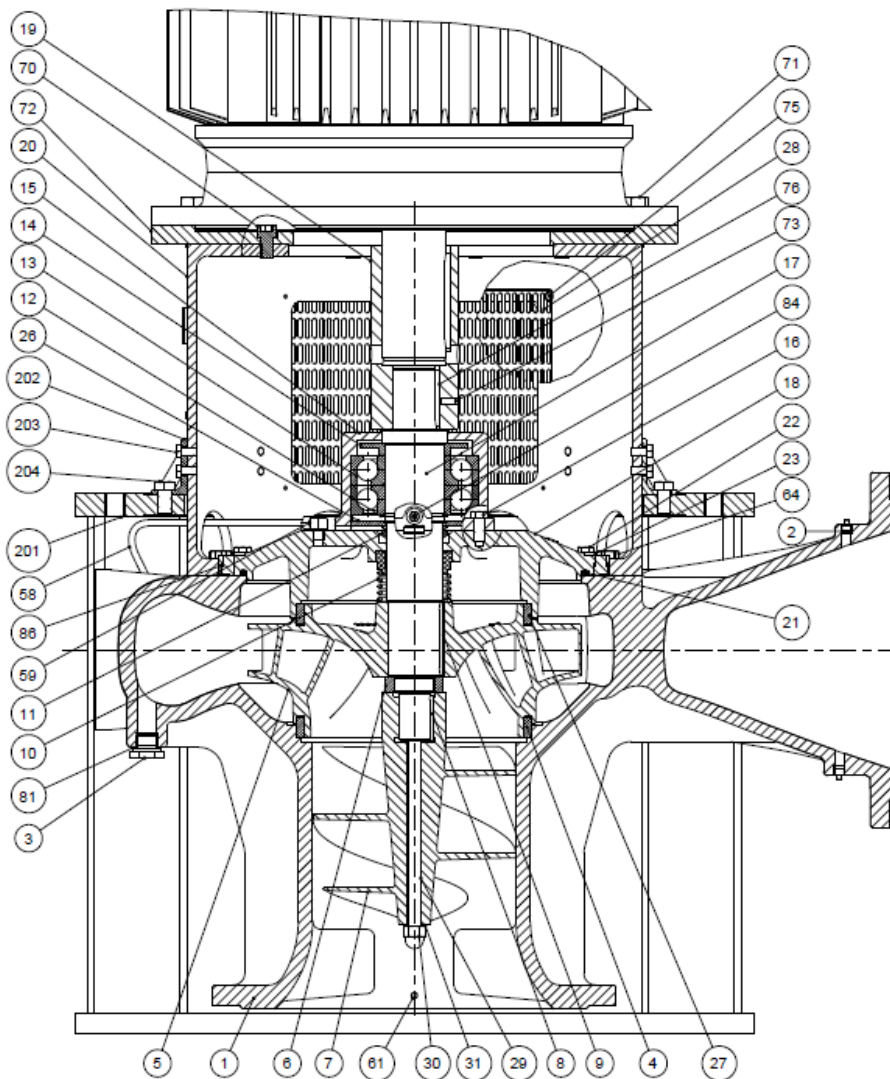

- | | |
|-----|----------------------|
| 1 | Pump casing |
| 2 | Pipe plug |
| 3 | Pipe plug |
| 4 | Sealing ring |
| 5 | Impeller |
| 6 | Stop ring |
| 7 | Inducer |
| 8 | Key |
| 9 | Key |
| 10 | Mech. shaft seal |
| 11 | Water deflector |
| 12 | Ring lock |
| 13 | Ball bearing |
| 14 | Support disc |
| 15 | Bearing cover |
| 16 | Set screw |
| 17 | Shaft |
| 18 | Rear cover |
| 19 | Coupling |
| 20 | Motor bracket |
| 21 | O-ring |
| 22 | Set screw |
| 23 | Lock washer |
| 26 | Cover under bearing* |
| 27 | Seal ring 2 |
| 28 | Guard |
| 29 | Stud |
| 30 | Cap nut |
| 31 | Spring washer |
| 58 | Pipe |
| 59 | Hexagon nipple |
| 61 | Hexagon nipple |
| 64 | Screw |
| 70 | Allen screw |
| 71 | Screw |
| 72 | Intermediate flange |
| 73 | Point screw |
| 75 | INSEX-screw |
| 76 | Sunk key |
| 81 | Sealing washer |
| 84 | Lubricator nipple |
| 86 | Point screw |
| 201 | Base frame |
| 202 | L support |
| 203 | Set screw |
| 204 | Set screw |
- *) Option -See Appendix B

43. ASSEMBLY DRAWING NSLH 250-210/300-250/350-310/400-390/500-500/600-630.

44. SPARE PARTS LIST NSLH 250-210/300-250/350-310/400-390/500-500/600-630

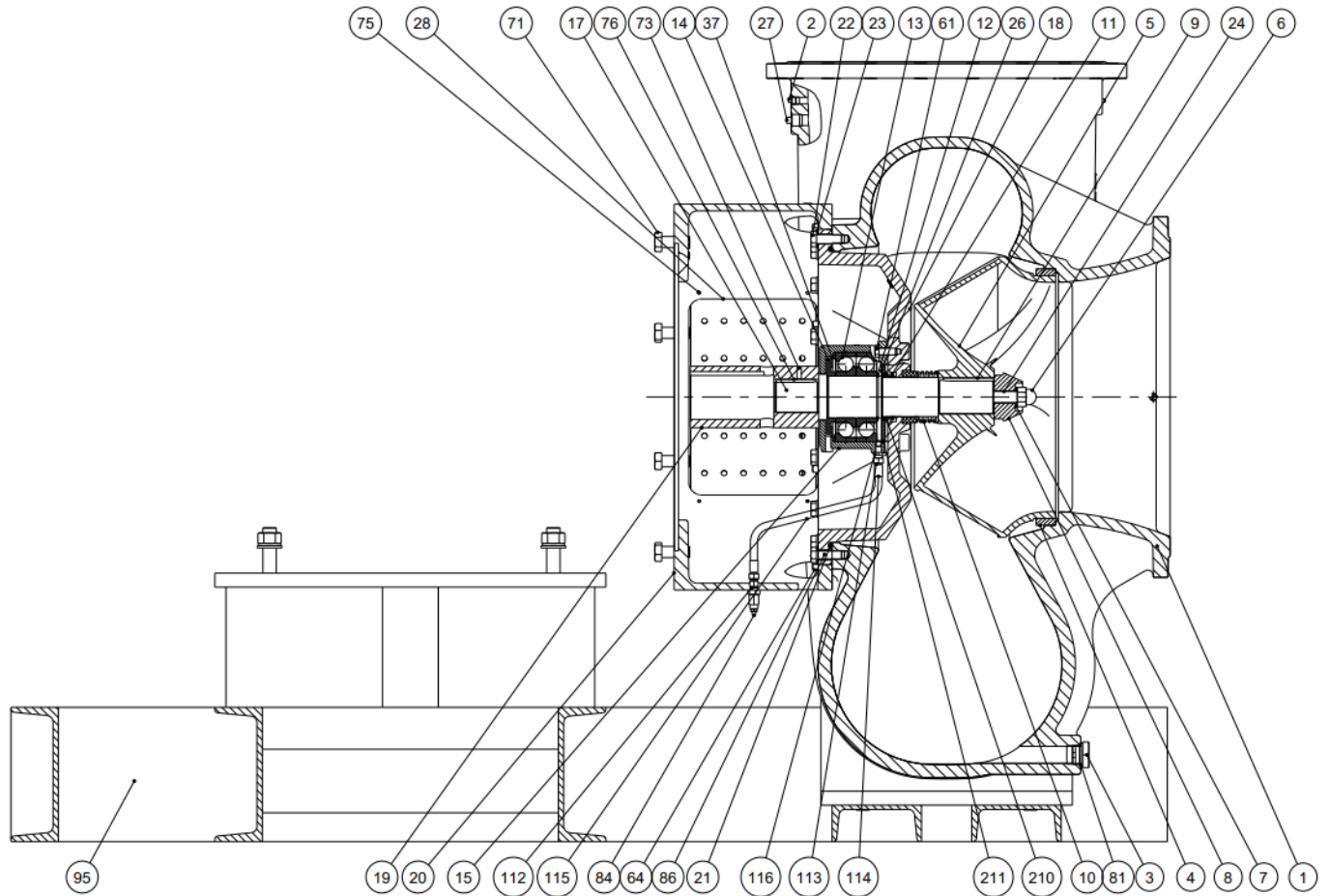

1 Pump casing	16 Screw	73 Pointed screw
2 Pipe plug	17 Shaft	75 INSEX-screw
3 Pipe plug	18 Rear cover	76 Sunk key
4 Sealing ring	19 Coupling	81 Sealing washer
5 Impeller	20 Motor bracket	84 Lubricator nipple
6 Cap nut	21 O-ring	86 Point screw
7 Spring washer	22 Set screw	95 Common baseplate
8 Inlet cone	23 Washer	112 Connector
9 Key	24 Stud bolt	113 Nipple
10 Mech. shaft seal	26 Cover under bearing	114 Ferrules
11 Water deflector	27 Plug	115 Hose
12 Ring lock	28 Guard	116 Nipple
13 Ball bearing	37 Orifice	210 Lip seal
14 Support disc	64 Set screw	211 O-ring
15 Bearing cover	71 Set screw	

45. ASSEMBLY DRAWING NSLV 250-210/300-250/350-310/400-390/500-500/600-630.

46. NSLV 250-210/300-250/350-310/400-390/500-500/600-630

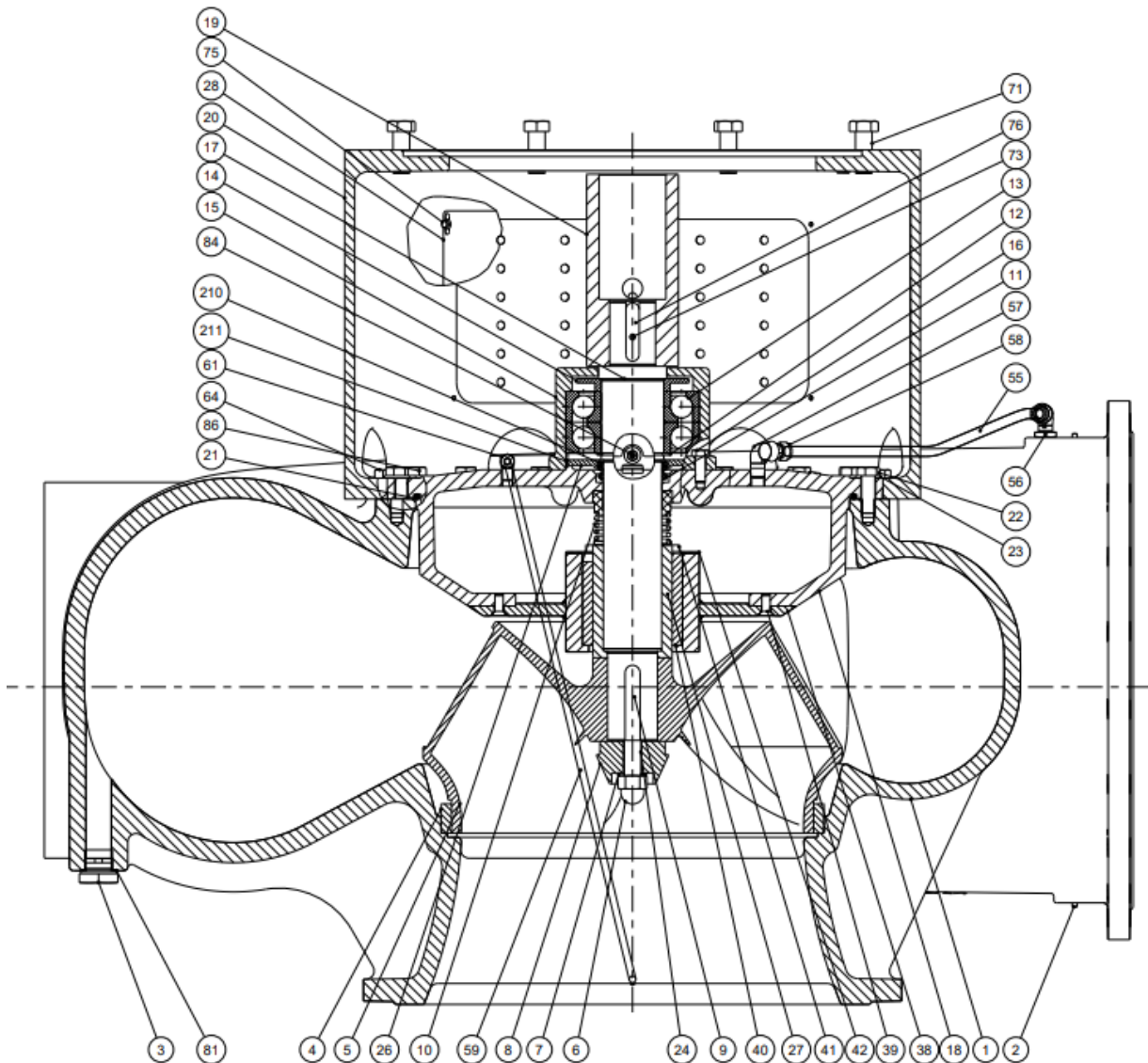

- | | | |
|---------------------|------------------------|----------------------|
| 1 Pump casing | 17 Shaft | 55 Tube seamless |
| 2 Pipe plug | 18 Rear cover | 56 Red.bush |
| 3 Pipe plug | 19 Coupling | 57 Elbow |
| 4 Sealing ring | 20 Motor bracket | 58 Nipple |
| 5 Impeller | 21 O-ring | 59 Tube |
| 6 Cap nut | 22 Set screw | 61 Screw connector |
| 7 Spring washer | 23 Lock washer | 64 Set screw |
| 8 Inlet cone | 24 Stud bolt | 71 Set screw |
| 9 Key | 26 Cover under bearing | 73 Pointed screw |
| 10 Mech. shaft seal | 27 Shaft sleeve | 75 Insex screw |
| 11 Water deflector | 28 Guard | 76 Sunk key |
| 12 Ring lock | 38 Slid bearing cover | 81 Sealing washer |
| 13 Ball bearing | 39 Allen screw | 84 Lubricator nipple |
| 14 Support disc | 40 Sliding bearing | 85 Point screw |
| 15 Bearing cover* | 41 Allen set screw | 210 Lip seal |
| 16 Set screw | 42 Lock plate | 211 O-ring |

47. DIMENSIONAL SKETCH

Please require a dimensional sketch of the actual pump from DESMI.

48. DESMI SUBSIDIARY

Subsidiary companies – DESMI Pumping Technology A/S				
Company Name	Address	Country	Telephone	Fax
DESMI Pumping Technology (Suzhou) Co.,Ltd.	No. 740 Fengting Avenue Weiting Sub District 215122 SIP Suzhou, P. R. China	China	+86 512 6274 0400	+86 512 6274 0418
DESMI Danmark A/S DESMI Contracting A/S DESMI Ocean Guard A/S	Tagholm 1 9400 Nørresundby	Denmark	+45 9632 8111	+45 9817 5499
DESMI GmbH	An der Reitbahn 15 D-21218 Seevetal	Germany	+49 407 519847	+49 407 522040
DESMI B.V	Texasdreef 7 3565 CL Utrecht	Netherlands	+31 302610024	+31 302623314
DESMI Norge AS	Skibåsen 33 h 4636 Kristiansand	Norway	+47 3812 2180	+47 3804 5938
DESMI Ltd.	"Norman House", Rosevale Business Park Parkhouse Industrial Estate (West) Newcastle Staffordshire ST5 7UB	United Kingdom	+44 1782 566900	+44 1782 563666
DESMI Singapore Pte.Ltd.	No. 8 Kaki Bukit Road 2, Ruby Warehouse Complex Unit no: # 02-13 417841	Singapore	+65 6748 2481	+65 6747 6172
DESMI Inc.	HQ, Manufacturing and sales 1119 Cavalier Blvd. Chesapeake, VA 23323	USA	(757) 857 7041	(757) 857 6989
DESMI Korea	503-8, DangSa Ri, Kijang-eup, Kijang-gun Busan	Korea	+82 51 723 8801 +82 70 7723 8804	+82 51 723 8803
DESMI SARL	21G rue Jacques Cartier F-78960 Voisins-le-Bretonneux RCS Versailles en cours	France	+33 (0) 1 30 43 97 10	+33 (0)130 43 97 11
DESMI UAE	Dubai Office Office 307 D-Wing P.O. Box 341489 Dubai Silicon Oasis	UAE	+971-56-300 3422	
DESMI India	413, Aditya Trade Centre Ameerpet Hyderabad – 500016	India	+91-9949339054	
DESMI Africa	Plot No.1848 Yacht Club Road Msasani Peninsular Dar es Salaam	Tanzania	+255 757597827	
DESMI Poland	Przedstawicielstwo w Polsce ul. Batalionu Platerówek 3 03-308 Warszawa	Poland	+48 22 676 91 16	+48 22 618 19 53

49. SERVICE CENTER-DENMARK

Service center - Denmark			
City	Address	Telephone	Fax
Nørresundby	Tagholm 1 9400 Nørresundby	+45 70236363	+45 9817 5499
Kolding	Albuen 18 C DK-6000 Kolding	+45 70236363	+45 75 58 34 65
Aarhus	Lilleringvej 20 DK-8462 Harlev J	+45 70236363	+49 407 522040
Hvidovre	Stamholmen 173 DK-2650 Hvidovre	+45 70236363	+45 3677 3399
Odense	Hestehaven 61 DK-5260 Odense S	+45 70236363	+45 6595 7565

APPENDIX A

Check length from motor shaft end to motor flange being within +/- 0.5mm of the nominal length (like 60, 80, 110, 140 and 170 mm).

If the motor shaft is too short then fit a pointed screw glued into the motor shaft end to adjust the pump shaft to correct mounting position – in order to ensure correct build in length for the ELK shaft seal.

If the motor shaft is too long then it has to be machined / milled to nominal length.

It has to be checked if the shaft sealing have the correct length when mounted on the pump shaft as shown below. I.e. there shall always be 44.5 ± 0.5 mm from sliding surface on the seat to the end of the rotating part, on the sizes of ELK sealing used by DESMI. Please observe that the rotating part protrudes 2 mm beyond the shoulder on the pump shaft as shown below.

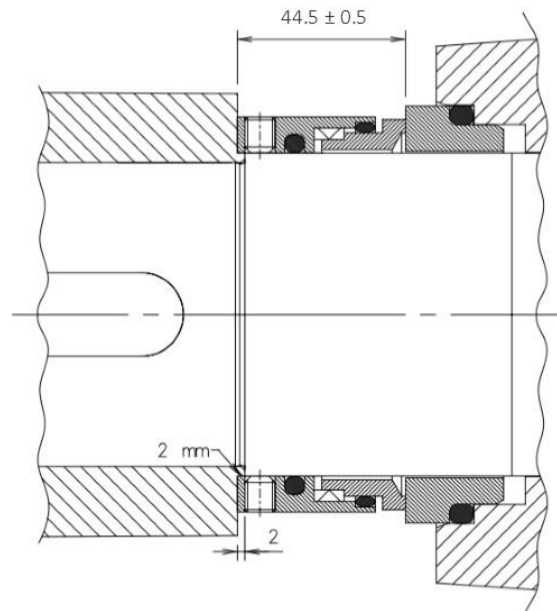

Also make sure that the electric motor is with locked bearing in the drive end – i.e. there must not be forced axial stroke of the electric motor.

Notice ! Never use mineral oil / fat as grease, as rubber parts as standard are in EPDM.

Notice ! Never put grease on the sliding surfaces! They must be completely dry, dust-free and clean during the mounting procedure. Also any fingerprints shall be removed with alcohol or another suitable solvent.

Notice: ELK shaft seals must be turned after installation ... so O-rings, springs and sliding surfaces can slip into right placement before pressure testing. This is done by mounting the seal as described and later turn the shaft about 10 revolutions - with water in the pump - but without adding pressure. Then pressure test the pump as normally done.

APPENDIX B

Assembly drawing of Lip seal kit in cover under bearing.

- The lip seal kit is optional.

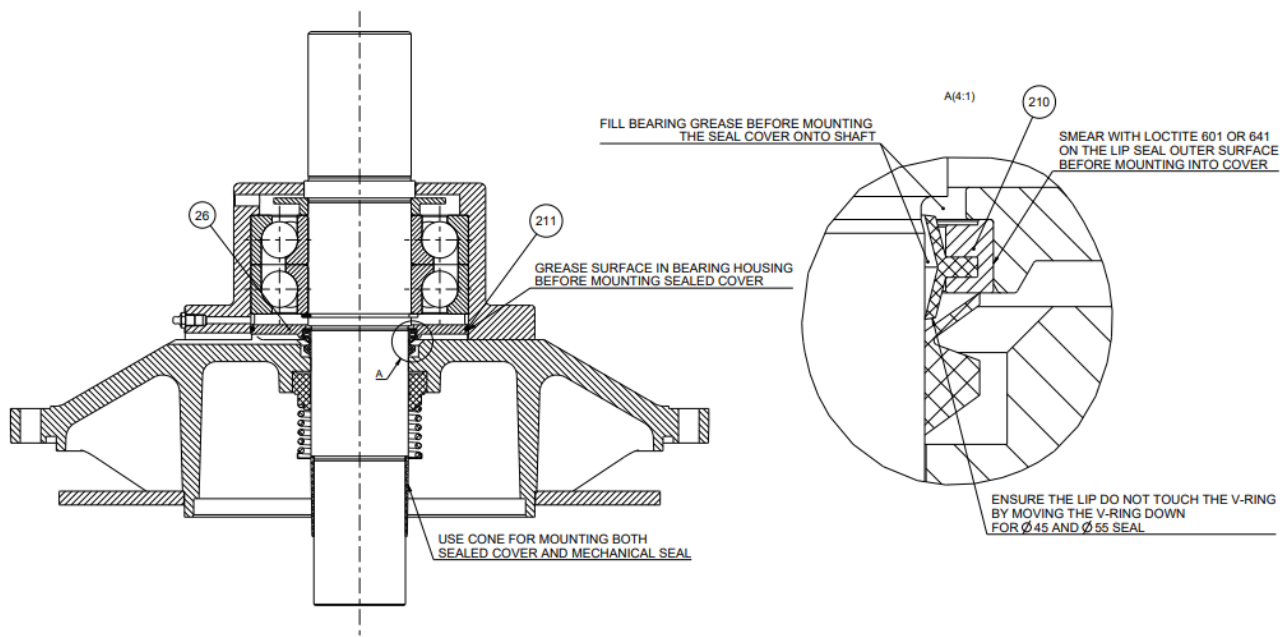

SPARE PARTS LIST

- | | |
|-----|---------------------|
| 26 | Cover under bearing |
| 210 | Lip Seal |
| 211 | O-ring |