

OPERATION AND MAINTENANCE INSTRUCTIONS

DESMI self-priming centrifugal pump

TYPE SA Monobloc design

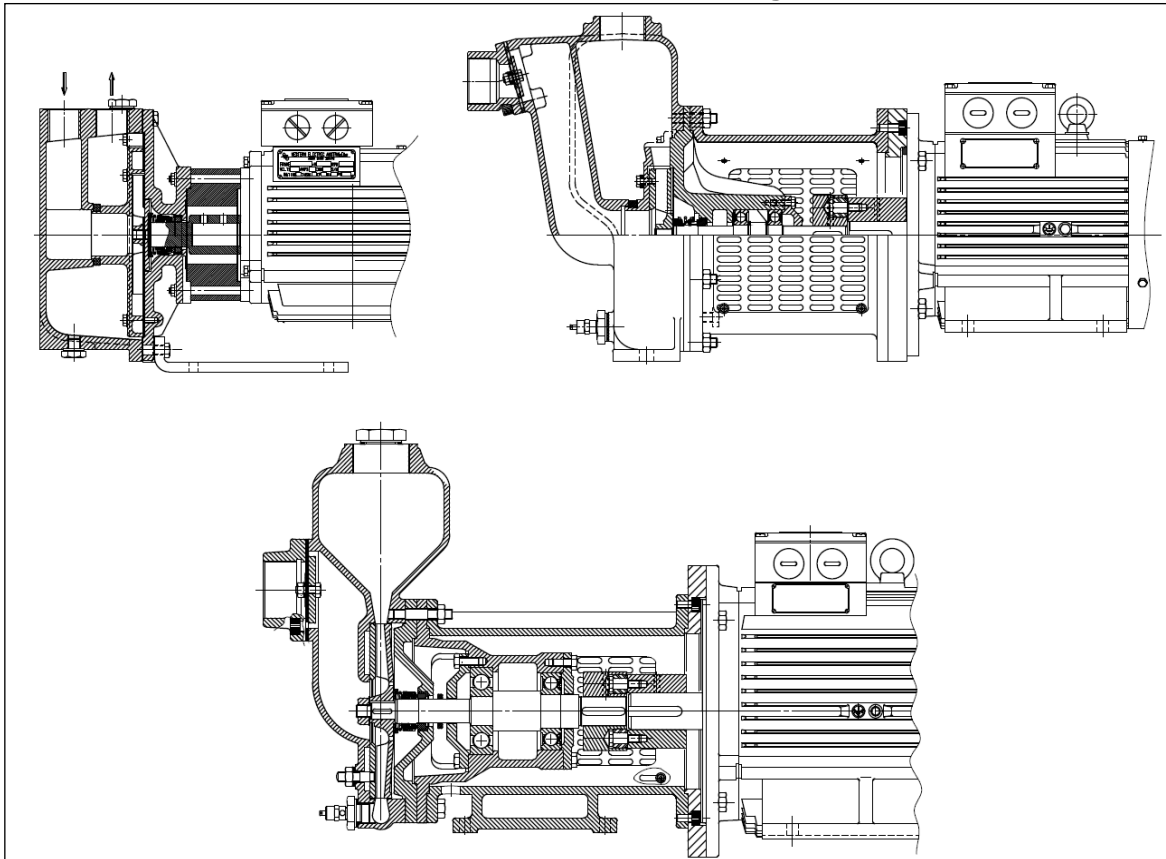

DESMI Pumping Technology A/S Tagholm 1 – DK-9400 Nørresundby – Denmark

Tel.: +45 96 32 81 11
Fax: +45 98 17 54 99
E-mail: desmi@desmi.com
Internet: www.desmi.com

Manual: T1517	Language: English	Revision: G (09/24)
------------------	----------------------	------------------------

Special pump nr.



Table of Contents:

1. PRODUCT DESCRIPTION	1
1.1 DELIVERY	1
2. TECHNICAL DATA	1
2.1 EXPLANATION OF THE TYPE NUMBER	1
2.2 TECHNICAL DESCRIPTION	2
3 . INSTALLATION.....	3
3.1 MOUNTING/FASTENING	3
3.2 WIRING.....	3
4. TRANSPORT/ STORAGE	4
5. INSPECTING THE PUMP	4
5.1 INSPECTION	4
5.2 FITTING SHAFT SEAL	4
5.3 SHAFT	5
6. FROST PROTECTION	5
7. DISMANTLING.....	5
8. START-UP.....	5
8.1 STARTING	5
9. SYSTEM BALANCING.....	6
10. INSPECTION AND MAINTENANCE	8
10.1 DRAINING THE PUMP	8
10.2 BEARINGS	8
11. REPAIRS - ORDERING SPARE PARTS.....	8
12. OPERATING DATA	9
13. EU DECLARATION OF CONFORMITY	10
14. INFORMATION RELEVANT FOR DISASSEMBLY OR DISPOSAL AT END-OF-LIFE.....	11

1. PRODUCT DESCRIPTION

These operation and maintenance instructions apply to the DESMI SA-pump in Monobloc design.

DESMI SA is a single-stage self-priming centrifugal pump with stainless steel shaft and mechanical shaft seal. The SA-pump is further equipped with a semi-open impeller which does not choke as easily as a closed impeller.

The pump is suitable for pumping clean and polluted liquids with temperatures between 0 and 80°C. With special shaft seal up to 120°C.

The suction branch of the pump is mounted well above impeller inlet. This is an advantage as the pump will not - in case of a non-return valve leakage - lose all the priming water and consequently the priming ability.

The pump has compact structure which provide convenient installation without having to align the coupling. As the pump is self-priming, a foot valve will not be necessary on the suction line, just as the pump, contrary to ordinary centrifugal pumps, will resume pumping if, for a short moment, the liquid has been lowered to a level below the suction pipe.

The pump is particularly suitable for the pumping of water in connection with e.g. cooling of diesel engines, as bilge pump, ballast pump, irrigation, washing plants, air conditioning, cooling systems, and sanitary systems, etc. Furthermore, in the majority of cases where the transport of liquid is required within industry.

1.1 DELIVERY

- Check on receipt that the delivery is complete and undamaged.
- Defects and damages, if any, to be reported to the carrier and the supplier immediately in order that a claim can be advanced.

2. TECHNICAL DATA

The pumps are manufactured in various material combinations which appear from the type number on the name plate. See below.

2.1 EXPLANATION OF THE TYPE NUMBER

All the SA-pumps are provided with a name plate. The type number indicated on the name plate is built up as follows:

SA-XXX-YYY-ZZ-MRO

XXX,YYY,ZZ : Pump size where

XXX : Suction branch diameter.

YYY : Standard impeller diameter.

ZZ : Height of the impeller blades.

M : The material combination of the pump.

R : The assembly combination of the pump.

O : The direction of rotation of the pump, anti-clockwise/clockwise.

M may be the following:

- A : Pump casing: Grey cast iron. Impeller/wear plate: Bronze.
- B : Pump casing: Grey cast iron. Impeller/wear plate: Stainless steel.
- C : All grey cast iron.
- D : Casing: Bronze. Impeller/wear plate: Bronze.
- E : All stainless steel material.
- F : All aluminium.

The pumps are available in other material combinations at request.

R may be the following: **(This manual is only for 02 type)**

- 01 : Flange-mounted with magnetic clutch and pulley.
- 02 : Flange-mounted with electric motor.
- 03 : Flange-mounted with hydraulic motor, or with petrol or diesel engine.
- 04 : Mounted with manual disengaging clutch and pulley.
- 05 : Mounted with manual disengaging clutch for direct coupling.
- 06 : Mounted on base frame with V-belt drive.
- 07 : Mounted on base frame with petrol or diesel engine, or with hydraulic or electric motor.
- 08 : Mounted on a trolley with petrol or diesel engine, or with hydraulic or electric motor.
- 09 : With bare shaft end.
- 10 : Special-tailored according to task.

Before putting a pump into operation, the suitability of the material combination of the pump must always be taken into consideration. In case of doubt, contact the supplier.

Pumps in material combinations A and C are primarily used for fresh water.
Pumps in material combination D are primarily used for sea water.

If the pumps are designed for special purposes the following is to be indicated:

Pump No. :
Pump type :
Application :
Comment :

2.2 TECHNICAL DESCRIPTION

The noise level indicated is the airborne noise including the motor. The noise depends on the motor type supplied, as the noise from the pump can be calculated as the noise level of the motor + 2dB(A).

The noise level of the motor appears from the instruction manual for the motor.

The pump capacity appears on the name plate of the pump. If the pump has been delivered without motor, the pump capacity is to be indicated on the plate when mounting the motor.

All pumps from size SA35 (inclusive) are equipped with a relief valve.

The permissible loads on the flanges are indicated in the following table:

Pump	Fv (N)	Fh (N)	3 F (N)	3 Mt (Nm)
SA-25-122	650	500	820	100
SA-35-135	900	700	1140	140
SA-50-180	1250	950	1550	170

- Fv : The max. permissible sum of the vertical forces on the two flanges.
 Fh : The max. permissible sum of the horizontal forces on the two flanges.
 3 F : The vectorial sum of the two forces Fv and Fh.
 3 Mt : The max. permissible sum of the torques on the two flanges.

In connection with the permissible loads on the flanges the following is to be observed:

$$\left(\frac{\sum F_{calc}}{\sum F} \right)^2 + \left(\frac{\sum M_{calc}}{\sum M_t} \right)^2 < 2$$

Where index "calc" is the values calculated by the user.

3 . INSTALLATION

3.1 MOUNTING/FASTENING

The pump can be mounted on board directly, and don't need to spend extra time to align centre line of pump and motor.

The pump must be installed with horizontal shaft and the pump casing discharge side vertically upwards.

The max. permissible loads on the flanges stated in paragraph 2.2. are to be observed.

The suction line to the pump is to be mounted carefully, so that it is absolutely tight, as even small leakages may impede the priming. When pumping polluted liquids a strainer is necessary. The strainer must be equipped with a sieve, the passage area of which is to be 3 x the area of the suction pipe. The mesh size is to be 1-3 mm smaller than the height of the impeller blades of the pump in question.

The pipes are to be arranged in such a way that stresses resulting from fluctuations in temperature will not have any effect on the pump. Because of the priming of the pump the pressure pipe is to be arranged so that water locks in the pipe are avoided. While installing the pump the following must be observed:

- Avoid distortion of the base plate.
- Avoid distortion of the piping system.



At installations pumping hot or very cold liquids, the operator must be aware that it is dangerous to touch the pump surface, and, consequently, he must take the necessary safety measures.



3.2 WIRING

Wiring to be carried out by authorised skilled workmen according to the rules and regulations in force.

4. TRANSPORT/ STORAGE

The weights of the pumps in A02/D02 combination (without motor) are stated in the following table:

Pump	Weight(Kg)	A/D
SA 25-122	23/25	
SA 35-135	41/45	
SA 50-180	53/59	

Lift the pump by placing the rope around it and see to it that the pump is balanced.
The rope must not bear against sharp edges and corners.
Lifting eyes might be mounted in the pump and used instead.
Before shipment the pump is to be fastened securely on a pallet or the like.
The pump is to be stored in a dry area.

5. INSPECTING THE PUMP

5.1 INSPECTION

When the pump has been dismantled, check the following parts for wear and damage:

- Wear plate/impeller : Max. clearance 0.4 - 0.5 mm.
- Shaft seal/rear cover : Check seat for flatness and cracks.
Check rubber parts for elasticity.
- Bearings : Replace in case of wear and noise.

5.2 FITTING SHAFT SEAL

Before fitting the seat, clean the recess in the intermediate cover. When fitting the seat, remove the protective coating without scratching the lapped surface. Dip the outer rubber ring of the seat in olive oil (or another neutral oil). Now press the seat into place with the fingers, and check that all parts are correctly imbedded.

If it is necessary to use fitting tools, protect the sliding surface of the seat to prevent it from being scratched or cut. Lubricate the inner diameter of the rubber bellows on the slide ring with olive oil and push it over the shaft.

The use of a fitting bush as shown on the assembly drawing is recommended to avoid that the rubber bellows is cut. Push the slide ring over the shaft with the hand. If the rubber bellows is tight, use a fitting tool and take care that the slide ring is not damaged. If the carbon ring is not fixed, it is important to check that it is fitted correctly, i.e. the chamfered/lapped side is to face the seat. The carbon ring can be held by a little grease. When using oil on the shaft, the bellows will settle and seat in about 15 minutes and until then tightness should not be expected. After start, check by viewing the leak hole that there are no leaks.

If the pump is equipped with a shaft seal type different from a rubber bellows seal, contact DESMI and ask for an installation instruction.

5.3 SHAFT

When the pump has been assembled, check that the shaft rotates freely.

6. FROST PROTECTION

Pumps which are not in operation during frost periods are to be drained to avoid frost damage. Remove the plug at the bottom to empty the pump. Alternatively, it is possible to use anti-freeze liquids in normal constructions.

7. DISMANTLING



Before dismantling the pump make sure that it has stopped. Empty the pump of liquid before it is dismantled from the piping system. If the pump has been pumping dangerous liquids you are to be aware of this and take the necessary safety measures.

If the pump has been pumping hot liquids, take great care that it is drained before it is removed from the piping system.

8. START-UP



A self-priming centrifugal pump will not function until the pump casing has been filled with liquid. Remove the plug at the top of the pump casing and fill the pump with cold liquid. Fit the plug and the pump is ready for service.

The liquid also serves as coolant for the shaft seal. Consequently, the pump must under no circumstances be started before it has been primed with liquid. Furthermore, the pump must never run dry.

WARNING

For safety reasons the pump is only allowed to operate against closed discharge valve for a short time (max. 5 minutes and at a max. temperature of 80°C for standard pumps). Otherwise there is a risk of damage to the pump and, at worst, of a steam explosion. If the pump is not monitored, the installation of a safety device is recommended.

To protect the pump against unintentional operation it is equipped with a relief valve which opens at a pre-set pressure.

Be careful: When the valve opens, the escaping liquid will be hot.

The relief valve must in **no** circumstances be removed or re-adjusted!

As regards maintenance of the relief valve - see paragraph 10.

8.1 STARTING

Before starting the pump check that

- The shaft rotates freely without jarring sounds.
- The pump casing is filled with liquid.

Start the pump for a moment to check the direction of rotation. If the direction is correct (i.e. in the direction of the arrow), the pump may be started.

9. SYSTEM BALANCING

It is often difficult to calculate a manometric delivery head in advance. It is, however, decisively important to the quantity of liquid delivered.

A considerably smaller delivery head than expected will increase the quantity of liquid delivered, causing increased power consumption and perhaps cavitation in pump and piping. In the pump the impeller may show signs of heavy erosion caused by cavitation (corrosion) which may at times render an impeller unfit for use in a very short time. Not unusually do similar erosions occur in pipe bends and valves elsewhere in the piping system.

Therefore, after start-up, it is necessary to check either the quantity of liquid delivered or the power consumption of the pump e.g. by measuring the current intensity of the connected motor. Together with a reading of the differential pressure the quantity of water delivered can be determined against the characteristics of the pump.

Should the pump not function as intended, please proceed according to the fault-finding list. Bear in mind, though, that the pump was carefully checked and tested at the factory and that the majority of faults stem from the piping system.

FAULT	CAUSE	REMEDY
The pump does not prime	<ol style="list-style-type: none"> 1. The pump is not filled with liquid 2. Leaking non-return valve in pump 3. Wrong direction of rotation 4. Air is drawn in because of too little liquid or leaking suction line 5. Liquid lock in outlet line 6. Temperature of liquid too high 7. Air cannot escape on pressure side 	<p>Fill pump casing with liquid</p> <p>Remove foreign body in pump/Remove any coating on mating faces</p> <p>Change direction of rotation</p> <p>Lower suction pipe/Tighten suction line</p> <p>Change the pressure line so that the air can pass out freely</p> <p>Replace liquid in pump casing/Wrong dimensioning/</p> <p>Contact DESMI</p> <p>Ventilate the system</p>

<p>The pump has no or too low capacity</p>	<ol style="list-style-type: none"> 1. Wrong direction of rotation 2. Piping system choked 3. The pump is choked 4. Suction line leaks, pump takes air 5. Suction lift too high 6. Pump and piping system wrongly dimensioned 7. RPM too low 	<p>Change direction of rotation to clockwise when viewed from shaft end (the direction of the arrow) Clean or replace Clean the pump Find the leakage, repair the fault, non-return valve not submerged Check data sheet Q/H curve and NPSH or contact DESMI As 5</p> <p>Fit smaller V-belt pulley on pump. Change RPM of electric motor</p>
<p>FAULT</p>	<p>CAUSE</p>	<p>REMEDY</p>
<p>The pump uses too much power</p>	<ol style="list-style-type: none"> 1. Counter-pressure too low 2. The liquid is heavier than water 3. Foreign body in pump 4. Electric motor is running on 2 phases 5. RPM too high 6. Pump and electric motor not aligned. 	<p>Insert orifice plate or check valve/Contact DESMI Contact DESMI</p> <p>Dismantle the pump, remove the cause Check fuses, cable connection, and cable</p> <p>Fit bigger V-belt pulley on pump. Change RPM of electric motor. Align unit (see para. about alignment)</p>
<p>The pump capacity is unstable</p>	<ol style="list-style-type: none"> 1. Suction line leaks 2. Air pockets in suction line 3. The pump takes air 	<p>Tighten suction line Normally the disappear in a short time Liquid reservoir emptied/ Suction line not sufficiently submerged</p>
<p>The pump makes noise</p>	<ol style="list-style-type: none"> 1. Cavitation in pump 2. Defective bearings 	<p>Suction lift too high/ Suction line wrongly dimensioned/Liquid temperature too high.</p> <p>Replace bearings</p>

10. INSPECTION AND MAINTENANCE

- Before any inspection of the pump, check that the unit cannot be started unintentionally.
- The system is to be without pressure and drained of liquid.
- The repairman must be familiar with the type of liquid which has been pumped as well as with the safety measures he is to take when handling the liquid.
- Inspect the shaft seal for leaks at regular intervals.
- Activate the relief valve at regular intervals in order to check the function. If the valve is choked, replace or clean it, if possible.

10.1 DRAINING THE PUMP

When the piping system has been drained, note that there is still some liquid left in the pump. Remove the remaining liquid by dismantling the pipe plug at the bottom of the pump.

10.2 BEARINGS

The pump is equipped with ball bearings which were lubricated for life before leaving the factory. Therefore, they require no attention but are to be replaced in case of noise or bearing wear. Place a bead of grease on the sides of cleaned or newly mounted bearings. As far as semi-closed bearings are concerned, place grease on the open side of the bearing only.

A recommended grease quality on a lithium-basis is used:

ESSO	Beacon 2
BP.....	Energrease EP grease 2
Shell	Alvania grease 2
Mobil.....	Mobil lux grease EP 2
Castrol	Spherol AP2
Texaco.....	Multifak EP 2
Q8.....	Rembrandt EP 2 and Rubens
Statoil	Statoil Uniway U2

11. REPAIRS - ORDERING SPARE PARTS

When ordering spare parts please always state pump type and pump No. (appears on the name plate of the pump). See also spare parts drawing with item Nos.

12. OPERATING DATA

The following working pressures are allowed:

PUMP	SA-25-122	SA-35-135	SA-50-180
PRESSURE [bar]	4	4	5.5

The above-mentioned max. working pressure is **NOT** valid for pumps approved by a classification society. Pumps approved by classification societies have been pressure tested according to the requirements of these societies, i.e. a test pressure of 1.5 x the permissible working pressure. The test pressure is stated in the test certificate and stamped into the discharge flange of the pump.

The following max. numbers of revolutions are allowed for SA-pumps with full impeller diameter:

Pump	Max. Number of Revolutions
SA-25-122/12	3600 RPM
SA-35-135/12	3600 RPM
SA-50-180/4	3600 RPM
SA-50-180/6	3000 RPM
SA-50-180/8	2500 RPM

The capacities of the pumps appear on the name plates.

13. EU DECLARATION OF CONFORMITY

DESMI PUMPING TECHNOLOGY A/S, hereby declare that our pumps of the type SA Monobloc are manufactured in conformity with the following essential safety and health requirements in the COUNCIL DIRECTIVE 2006/42/EC on machines, Annex 1.

The following harmonized standards have been used:

EN/ISO 13857:2019	Safety of machinery. Safety distances to prevent danger zones being reached by the upper limbs
EN 809:1998 + A1:2009	Pumps and pump units for liquids – Common safety requirements
EN12162:2001+A1:2009	Liquid pumps – Safety requirements – Procedure for hydrostatic testing
EN 60204-1:2018	Safety of machinery – Electrical equipment of machines (item 4, General requirements)

Pumps delivered by us connected with prime movers are CE-marked and comply with the above requirements.

Pumps delivered by us without prime movers (as partly completed machinery) must only be used when the prime mover and the connection between prime mover and pump comply with the above requirements.

Nørresundby, September 20 2024



Henrik Mørkholt Sørensen
Managing Director

DESMI Pumping Technology A/S
Tagholm 1
9400 Nørresundby

14. INFORMATION RELEVANT FOR DISASSEMBLY OR DISPOSAL AT END-OF-LIFE

No damage materials are used in DESMI pumps – please refer to DESMI Green Passport (can be sent on request – contact a DESMI sales office) – i.e. common recycling companies can handle the disposal at end-of-life. Alternatively the pump and motor can be returned to DESMI at end-of-life for safe recycling.

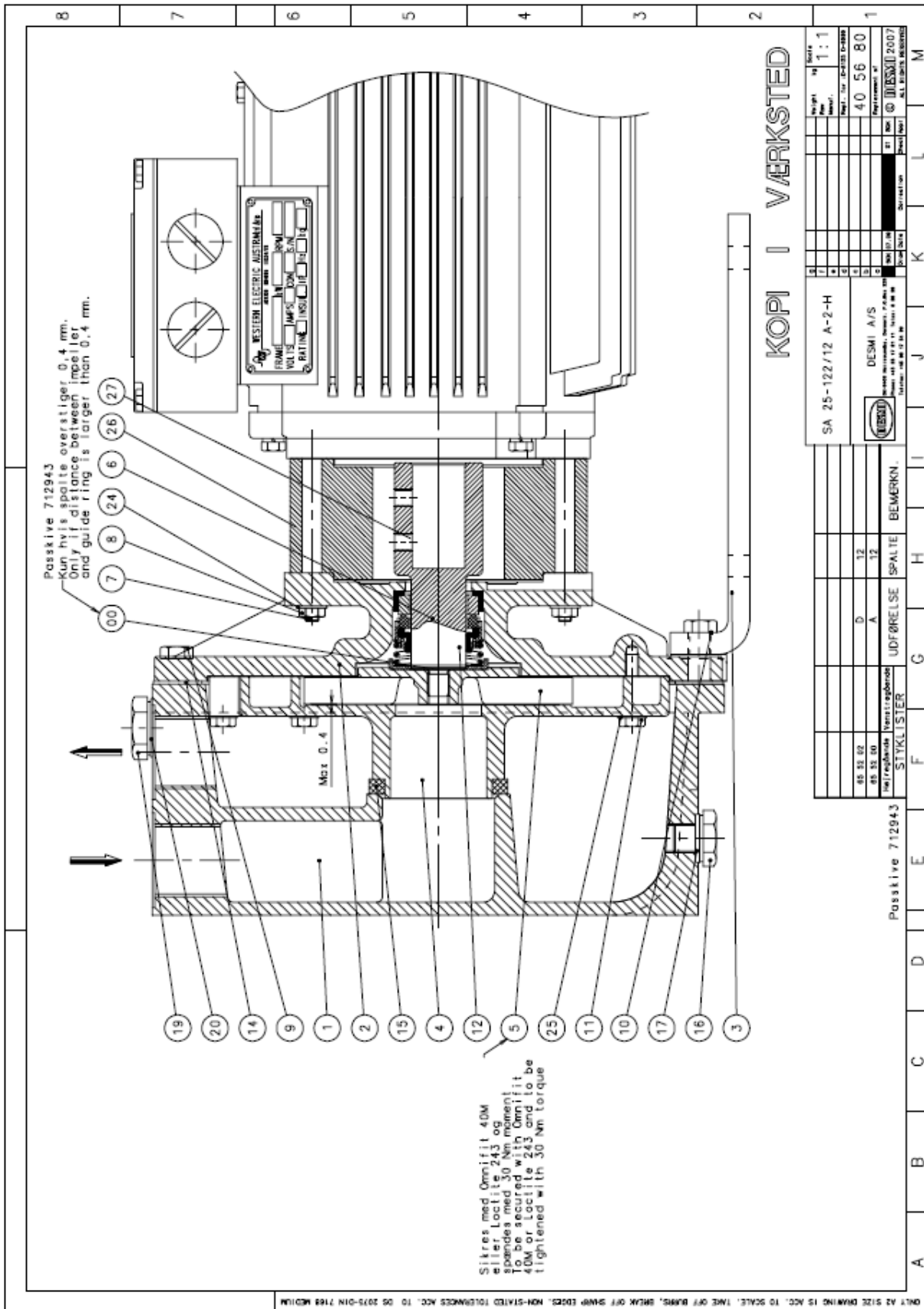

SA-25-122/12		
Pos.	Qty.	Description
1	1	Pump casing
2	1	Rear cover
3	1	Base plate
4	1	Guide vane piece
5	1	Impeller
6	1	Shaft
7	1	Stud
8	1	Nut
9	10	Set screw M 8X25
10	2	Set screw M 8X35
11	4	Set screw M 6X30
12	1	Mech. shaft seal ø 25
14	1	Gasket
15	1	Rubber ring Ø65/50X8
16	1	Plug 1/4"
17	1	Sealing washer 1/4"
19	1	Plug 3/8"
20	1	Sealing washer 3/8"
24	4	Spring washer M 8
25	4	Dube washer M 6
26	1	Adaptor flange
27	2	Point screw M 8X12

SA-35-135/02

Pos.	Qty.	Designation
1	1	Pump casing
2	1	Set screw M6x16
3	1	Suction piece
4	1	Clack valve
5	1	Washer
6	1	Nut M6
7	1	Dubo ring M6
8	4	Allen screw M10x25
9	1	Non return valve plate
10	1	Guide vane piece
11	1	Wear plate
12	4	Set screw M6x16
13	1	Impeller
14	1	Gasket
15	2	Dowty selon 1/2@ BSP
16	1	Pipe plug 1/2@ BSP
17	8	Nut M10
18	8	Stud M10x35
19	2	Set screw M6x20
19a	1	Set screw M6x40
20	1	Gasket
21	1	Bearing housing
22	1	Mech. shaft seal
23	2	Ball bearing 6304 RS
24	2	SS washer 20x28x2
25	4	Dubo ring M6
26	1	Cover
27	2	Set screw M6x16
30	1	Shaft
31	1	Sunk key 6x6x30
32	2	Shim
33	3	Dubo ring M6
34	2	Set screw M10x20
75	1	Pipe plug
76	1	Relief valve

SA-50-180/02		
Pos.	Qty.	Description
1	1	Pump casing
2	1	Check valve
3	1	Set screw M8x20
4	4	Allen screw M10x25
5	1	Clamp plate
6	1	Suction piece
7	1	Non return valve plate
8	8	Nut M10
9	1	Wear plate
10	1	Impeller nut 1/4" BSP
11	1	Impeller
12	1	Sunk key 5x5x20
13	1	Mech. shaft seal
14	3	Dubo ring M10
16	1	Gasket
17	1	Intermediate piece
18	8	Stud M10x50
19	1	Bearing housing
20	1	Cover
21	8	Set screw M8x20
22	1	Ball bearing 6406
23	1	Nut M8
24	1	Ball bearing 6307 RS
25	1	Shaft
26	1	Sunk key 7x8x45
28	1	Cover
31	1	Water deflector
32	1	Pipe plug 1" RG
33	1	Dowty selon 1" BSP
36	1	Lock nab
37	3	Stud M10x40
39	1	Dowty selon 1/2" BSP
40	1	Dubo ring M8
44	2	Set screw M10x30
45	2	Shim
75	1	Pipe plug 1/2" BSP
76	1	Relief valve

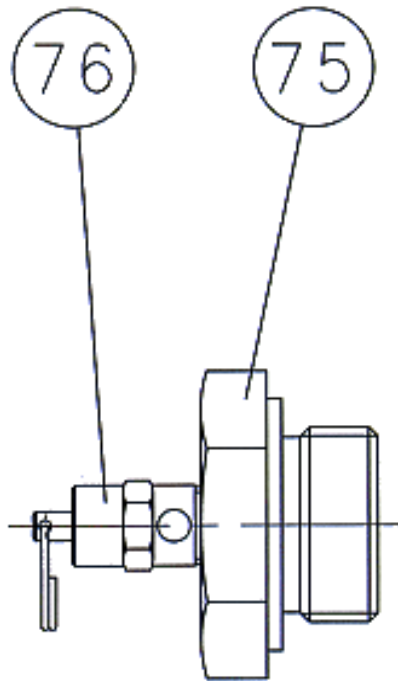

A/S De Smithske

P.O.Box 326 DK-2400 Nørresundby, Denmark.
 Phone: +45 98 32 81 11
 Telefax: +45 98 17 54 99

SIKKERHEDSVENTIL OG
 AFTAPNINGSPROP TIL SA PUMPER
 RELIEF VALVE AND
 PLUG FOR SA PUMPS
 ÜBERDRUCKVENTIL UND
 STOPFEN FÜR SA PUMPEN

40 52 95

Blad 1 af 1 blade

Dato 88.08.05

Udført af HSJ

Scale

Subject to alterations

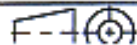

ALL RIGHTS RESERVED © DESMI