

OPERATION AND MAINTENANCE INSTRUCTIONS

DESMI centrifugal pump

MODULAR H Monobloc

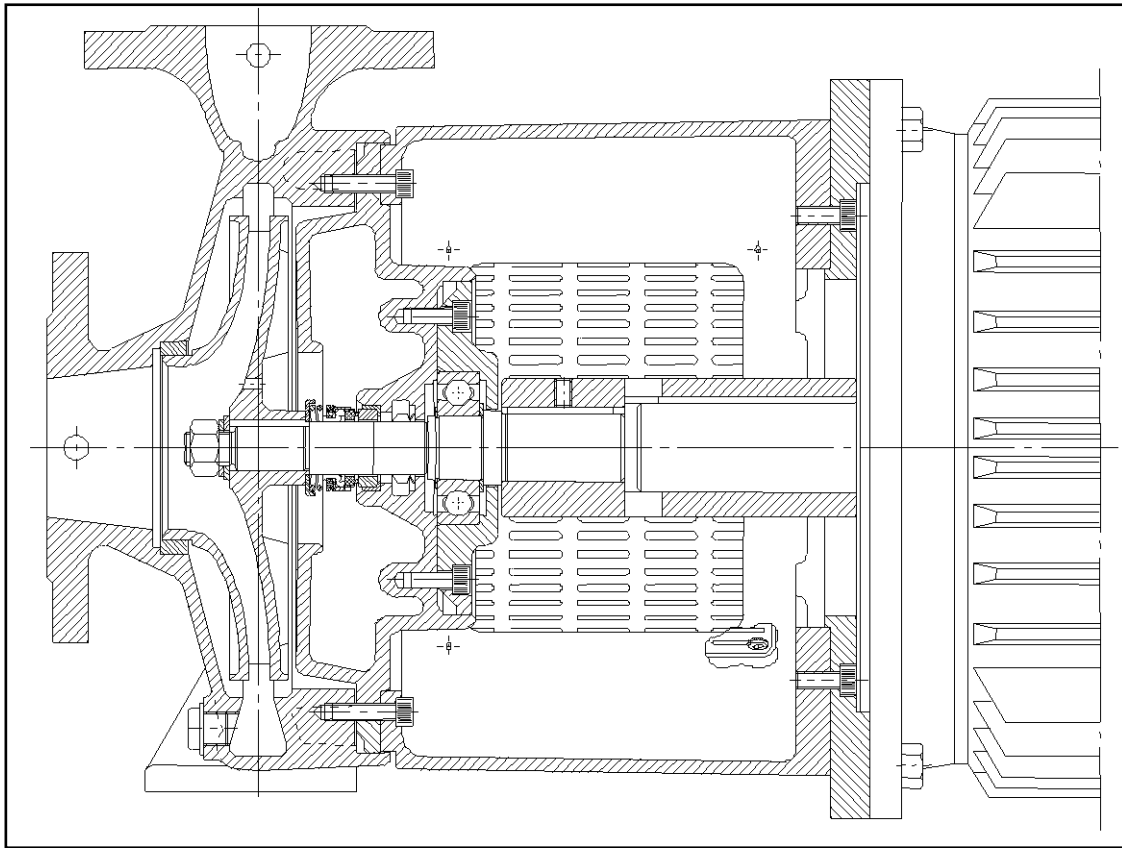

DESMI PUMPING TECHNOLOGY A/S

Tagholm I, DK-9400 Nørresundby Tel. +45 96 32 81 11 Fax +45 98 17 54 99

Manual: T1351	Language: English	Revision: J (09/24)
------------------	----------------------	------------------------



Special pump No.

Table of Contents:

1. PRODUCT DESCRIPTION	3
1.1 DELIVERY	3
2. TECHNICAL DATA	3
2.1 EXPLANATION OF THE TYPE NUMBER	3
2.2 TECHNICAL DESCRIPTION	4
3. INSTALLATION	5
3.1 MOUNTING/FASTENING	5
3.2 WIRING	5
4. TRANSPORT/STORAGE	6
5. DISMANTLING	6
5.1 ACCESS TO IMPELLER.....	6
5.2 DISMANTLING SHAFT SEAL.....	6
5.3 DISMANTLING SEAT.....	7
5.4 DISMANTLING BEARING	7
5.5 INSPECTION	7
5.6 DISMANTLING COUPLING.....	7
6. ASSEMBLING	7
6.1 FITTING SEALING RING IN PUMP CASING	7
6.2 FITTING BEARING	7
6.3 FITTING WATER DEFLECTOR.....	7
6.4 FITTING SHAFT SEAL	7
6.5 FITTING IMPELLER	8
6.6 FITTING BEARING COVER AND SHAFT SEAL COVER	8
6.7 SHAFT	8
6.8 FITTING COUPLING	8
7. FROST PROTECTION	8
8. DISMANTLING	8
9. START-UP	9
9.1 STARTING	9
10. SYSTEM BALANCING	9
11. INSPECTION AND MAINTENANCE.....	10
11.1 DRAINING THE PUMP	10
11.2 BEARING.....	10
12. REPAIRS	11
12.1 ORDERING SPARE PARTS	11
13. OPERATING DATA	11
14. EU DECLARATION OF CONFORMITY	12
15. INFORMATION RELEVANT FOR DISASSEMBLY OR DISPOSAL AT END-OF-LIFE	13
16. ASSEMBLY DRAWING.....	14
17. SPARE PARTS LIST	14
18. DIMENSIONAL SKETCH	15

1. PRODUCT DESCRIPTION

These operation and maintenance instructions apply to the DESMI MODULAR H Monobloc pump series. The pumps are available in sizes ranging from 40 to 80 mm on the pressure flange. The suction flange is bigger than the pressure flange. DESMI H is a single-stage centrifugal pump with stainless steel shaft, mechanical shaft seal, and closed impeller. The pump is suitable for the pumping of clean and polluted liquids with temperatures between 0 and 80°C. With special shaft seal and ball bearing up to 120°C. Max. number of revolutions: 3600 RPM.

The pump has horizontal inlet on the centre line and vertical outlet at the top. The back of the impeller is equipped with relief blades to reduce the load on the bearings. Relief holes in the impeller ensure circulation of liquid for the shaft seal and prevent overheating of the shaft seal during normal operation.

The pump is particularly suitable for the pumping of water in connection with washing plants, air conditioning, cooling systems, and sanitary systems, etc. Furthermore, in the majority of cases where the transport of liquid is required within industry.

1.1 DELIVERY

- Check on delivery that the shipment is complete and undamaged.
- Defects and damages, if any, to be reported to the carrier and the supplier immediately in order that a claim can be advanced.

2. TECHNICAL DATA

The pumps are manufactured in various material combinations, which appear from the type number on the nameplate. See below.

2.1 EXPLANATION OF THE TYPE NUMBER

All the H-pumps are provided with a nameplate. The type number indicated on the nameplate is built up as follows:

H-XX-YYY-MR

XX.YYY: Pump size

M: The material combination of the pump.

R: The assembly combination of the pump.

M may be the following:

A: Standard. Casing: GG20. Impeller: AIBz.

C: All cast iron.

D: Casing: RG5, Impeller: AIBz.

E: Casing and shaft seal cover: NiAIBz and bronze alloy. Impeller and sealing rings: NiAIBz.

The pumps can be delivered in other material combinations, which are agreed with the supplier.

R may be the following:

- 02: Monobloc, flange-mounted with electric motor.
- 07: On a base plate with petrol or diesel engine, or with electric motor.
- 09: With bare shaft end.
- 10: Special-tailored according to task.

Any use of the pump is to be evaluated on the basis of the materials used in the pump. In case of doubt, contact the supplier.

The pump is particularly suitable for the pumping of water in connection with the cooling of diesel engines and cooling units, as bilge pump, ballast pump, fire pump, for irrigation, fish farms, water works, water lowering, etc.

Pumps in material combinations A and C are primarily used for fresh water.
Pumps in material combination D are primarily used for seawater.

If the pumps are designed for special purposes the following is to be indicated:

Pump No. : _____
Pump type: _____
Application: _____
Comment: _____

2.2 TECHNICAL DESCRIPTION

The noise level indicated is the airborne noise including the motor. The noise depends on the motor type supplied, as the noise from the pump can be calculated as the noise level of the motor + 2dB(A). The noise levels indicated are for pumps with MEZ-motors.

The capacity of the pump appears from the nameplate on the pump. If the pump has been delivered without motor, the pump capacity is to be indicated on the plate when mounting the motor.

The permissible loads on the flanges appear from the following table:

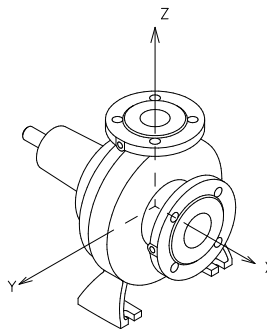

Pump	Ø Pressure branch	Fv N	Fh N	Σ F N	Σ Mt Nm
H-40-160	40	1350	1000	1700	220
H-50-160	50	1350	1000	1700	220
H-50-200	50	1350	1000	1700	200
H-65-160	65	1450	1050	1800	270
H-65-200	65	1450	1050	1800	270
H-80-200	80	1800	1250	2200	470

In connection with the permissible loads on the flanges the following is to be observed:

$$\frac{2}{3} F_{zout} + F_{zin} \leq F_v$$

$$\sqrt{F_{xin}^2 + F_{yin}^2} + \sqrt{F_{xout}^2 + F_{yout}^2} \leq F_h$$

$$\sqrt{M_{xin}^2 + M_{yin}^2 + M_{zin}^2} + \sqrt{M_{xout}^2 + M_{yout}^2 + M_{zout}^2} \leq M_t$$

$$\left(\frac{\Sigma F \text{ calc}}{\Sigma F} \right)^2 + \left(\frac{\Sigma M \text{ calc}}{\Sigma M_t} \right)^2 < 2$$

where indices "in" is suction branch, "out" is pressure branch and "calc" are the values calculated by the user.

3. INSTALLATION

3.1 MOUNTING/FASTENING

The pump should be mounted and fastened on a solid base plate with a flat and horizontal surface to avoid distortion.

The max. permissible loads on the flanges stated in paragraph 2.2 are to be observed.



At installations pumping hot or very cold liquids, the operator must be aware that it is dangerous to touch the pump surface, and, consequently, he must take the necessary safety measures.

3.2 WIRING



Wiring to be carried out by authorized skilled workmen according to the rules and regulations in force.

4. TRANSPORT/STORAGE

The weights of the pumps (without motor) are stated in the following table, and the pumps are to be lifted as shown below.

Pump	Weight kg
H-40-160	30.0
H-50-160	32.0
H-65-160	39.0
H-50-200	40.0
H-65-200	46.0
H-80-200	66.5

The pump is to be stored in a dry area.

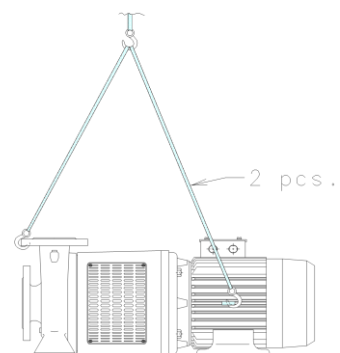

Before shipment the pump is to be fastened securely on pallets or the like.

The pump is to be lifted in the following way:

The lifting straps must not bear against sharp edges and corners.

5. DISMANTLING

5.1 ACCESS TO IMPELLER

Remove guards (28). Remove Allen screws (22), which hold the shaft seal cover and the monobloc bracket to the pump casing. The pump casing can now be pulled away allowing inspection of the impeller.

5.2 DISMANTLING SHAFT SEAL

Pull the shaft seal cover free of the monobloc bracket, by which the coupling is pulled off the motor shaft. Remove nut (6). Pull off the impeller and remove sunk key (9). Remove Allen screws (16), which hold the bearing cover to the shaft seal cover, pull shaft seal cover and bearing cover apart, by which shaft seal and water deflector are pulled off the shaft.

5.3 DISMANTLING SEAT

Press out the seat from behind the shaft seal cover.

5.4 DISMANTLING BEARING

Before dismantling bearing remove ring lock (12). Then pull the shaft/coupling out of the bearing cover and press the bearing out of the bearing cover.

5.5 INSPECTION

When the pump has been dismantled, check the following parts for wear and damage:

- Sealing ring/impeller : Max. clearance 0.4-0.5 mm measured in radius.
- Shaft seal/shaft seal cover : Check the seat for flatness and cracks.
Check the rubber parts for elasticity.
- Bearing : Replace in case of wear and noise.

5.6 DISMANTLING COUPLING

It is not necessary to remove the coupling during normal maintenance. Otherwise dismantle the coupling by removing the pointed screw and pulling off the coupling. If the coupling is dismantled on the assembled pump, take care that pulling too hard in the coupling does not damage the bearing. If the coupling is removed after dismantling the pump, fix the shaft at the thread on the opposite shaft end while the coupling is pulled off.

6. ASSEMBLING

6.1 FITTING SEALING RING IN PUMP CASING

When fitted, the sealing ring is to bear against the shoulder of the pump casing.

6.2 FITTING BEARING

Place the support disc (14) in the bearing cover and press the bearing into place in the bearing cover. Lead the shaft through the bearing cover, support disc and bearing, and press the bearing into place up against the support disc. Fit ring lock (12).

6.3 FITTING WATER DEFLECTOR

Tighten the bearing cover to the shaft seal cover. Lead the water deflector over the shaft until it touches the shaft seal cover and then further 1-1.5 mm into the shaft seal cover.

6.4 FITTING SHAFT SEAL

Before fitting the seat, clean the recess in the shaft seal cover. When fitting the seat, remove the protective coating without scratching the lapped surface. Dip the outer rubber ring of the seat into olive oil (or another neutral oil). Now press the seat into place with the fingers and check that all parts are correctly imbedded. If it is necessary to use tools for assembling, then protect the sliding surface of the seat to prevent it from being scratched or cut. Lubricate the inner diameter

of the slide ring rubber bellows with olive oil and push it over the shaft. The use of a fitting bush as shown on the assembly drawing is recommended to avoid that the rubber bellows is cut. Push the slide ring over the shaft with the hand. If the rubber bellows is tight, use a fitting tool and take care that the slide ring is not damaged.

If the carbon ring is not fixed, it is important to check that it is fitted correctly, i.e. the chamfered/lapped side is to face the seat. The carbon ring can be held by a little grease. When using oil on the shaft, the bellows will settle and seat in abt. 15 minutes and until then tightness should not be expected. After start, check by viewing the leak hole that there are no leaks.

6.5 FITTING IMPELLER

Fit the sunk key in the shaft and lead the impeller towards the shoulder of the shaft. Take care that the ring at the end of the shaft seal spring locates in the recess of the impeller. Secure the impeller with a washer and a nut.

6.6 FITTING BEARING COVER AND SHAFT SEAL COVER

Place the gasket between pump casing and shaft seal cover on the shaft seal cover where it can be held with a little grease. Fit and fasten bearing cover and shaft seal cover. Check that the drain passage for the shaft seal faces downwards.

6.7 SHAFT

When the pump has been assembled, check that the shaft rotates freely.

6.8 FITTING COUPLING

Fit sunk key (76). If the coupling is fitted on the assembled pump, take care that you do not damage the bearing by pressing the coupling too hard. The coupling might be heated to facilitate the fitting. If the coupling is fitted before assembling the pump, the shaft is supported at the opposite shaft end while the coupling is pressed into place. When the coupling bears against the shoulder of the pump shaft, fit the pointed screw.

7. FROST PROTECTION

Pumps, which are not in operation during frost periods, are to be drained to avoid frost damage. Remove the plug at the bottom to empty the pump. Alternatively, it is possible to use anti-freeze liquids in normal constructions.

8. DISMANTLING



Before dismantling the pump make sure that it has stopped. Empty the pump of liquid before it is dismantled from the piping system. If the pump has been pumping dangerous liquids you are to be aware of this and take the necessary safety measures. If the pump has been pumping hot liquids, take great care that it is drained before it is removed from the piping system.

9. START-UP

A centrifugal pump will not function until it has been filled with liquid between foot valve and somewhat above the impeller of the pump.



The liquid also serves as coolant for the shaft seal. In order to protect the shaft seal the pump must not run dry.

ATTENTION

For safety reasons the pump is only allowed to operate against closed discharge valve for a short time (max. 5 minutes and at a max. temperature of 80°C for standard pumps). Otherwise there is a risk of damage to the pump and, at worst, of a steam explosion. If the pump is not monitored, the installation of a safety device is recommended.

9.1 STARTING

Before starting the pump check that:

- the shaft rotates freely without jarring sounds.
- the pump casing and the suction line are filled with liquid.

Start the pump for a moment to check the direction of rotation. If the direction is correct (i.e. in the direction of the arrow) the pump may be started.

10. SYSTEM BALANCING

It is often difficult to calculate a manometric delivery head in advance. It is, however, decisively important to the quantity of liquid delivered.

A considerably smaller delivery head than expected will increase the quantity of liquid delivered, causing increased power consumption and perhaps cavitation in pump and piping. In the pump the impeller may show signs of heavy erosion caused by cavitation (corrosion) which may at times render an impeller unfit for use in a very short time. Not unusually do similar erosions occur in pipe bends and valves elsewhere in the piping system.

Therefore, after start-up, it is necessary to check either the quantity of liquid delivered or the power consumption of the pump e.g. by measuring the current intensity of the connected motor. Together with a reading of the differential pressure the quantity of water delivered can be determined against the characteristics of the pump.

Should the pump not function as intended, please proceed according to the faultfinding list. Bear in mind, though, that the pump was carefully checked and tested at the factory and that the majority of faults stem from the piping system.

FAULT	CAUSE	REMEDY
The pump has no or too low capacity	<ol style="list-style-type: none"> 1. Wrong direction of rotation 2. Piping system choked 3. The pump is choked 4. Suction line leaks Pump takes air 5. Suction lift too high 6. Pump and piping system wrongly dimensioned 	<p>Change direction of rotation to clockwise when viewed from shaft end (the direction of the arrow)</p> <p>Clean or replace Clean the pump Find the leakage/repair the fault, non-return valve not submerged</p> <p>Check data sheet Q/H curve and NPSH or contact DESMI As 5</p>
The pump uses too much power	<ol style="list-style-type: none"> 1. Counter-pressure too low 2. The liquid is heavier than water 3. Foreign body in pump 4. Electric motor is running on 2 phases 	<p>Insert orifice plate or check valve/contact DESMI Contact DESMI</p> <p>Dismantle the pump, remove the cause Check fuses, cable connection, and cable</p>
The pump makes noise	<ol style="list-style-type: none"> 1. Cavitation in pump 	<p>Suction lift too high/ Suction line wrongly dimensioned/Liquid temperature too high</p>

11. INSPECTION AND MAINTENANCE

Inspect the shaft seal for leaks at regular intervals.

- Before inspection of a pump without guard check that the pump cannot be started unintentionally.
- The system is to be without pressure and drained of liquid.
- The repairman must be familiar with the type of liquid which has been pumped as well the safety measures he is to take when handling the liquid.

11.1 DRAINING THE PUMP

When the piping system has been drained, note that there is still liquid in the pump. Remove the liquid by dismantling the pipe plug (75) at the bottom of the pump.

11.2 BEARING

The pump is equipped with a ball bearing with a nominal life of 25,000 working hours. The bearing is lubricated for life and requires no attention but is to be replaced in case of noise or bearing wear.

12. REPAIRS

12.1 ORDERING SPARE PARTS

When ordering spare parts please always state pump type and serial No. (appears from the nameplate of the pump). See also spare parts drawing with item Nos.

13. OPERATING DATA

The following max. working pressures are allowed:

PUMP	H-40-160	H-50-160	H-65-160	H-50-200	H-65-200	H-80-200
PRESSURE mWC	65	65	65	95	95	95

The above-mentioned max. working pressure is **NOT** valid for pumps approved by a classification society. Pumps approved by classification societies have been pressure tested according to the requirements of these societies, i.e. a test pressure of 1.5 x the permissible working pressure. The test pressure is stated in the test certificate and stamped into the discharge flange of the pump. The powers stated in the table below are the highest possible absorbed by the pump, whereas the min./max. values for flow and pressure indicate DESMI's recommended operating range for the pump.

Impeller diameter Ø	Max. Power kw 1450/1750/ 2950/3500 RPM	Min. Flow m ³ /h 1450/1750/ 2950/3500 RPM	Max. Flow m ³ /h 1450/1750/ 2950/3500 RPM	Min. Pressure mWC 1450/1750/ 2950/3500 RPM	Max. Pressure mWC 1450/1750/ 2950/3500 RPM
H-40-160 Ø175	0.8/1.3/5.7/9.4	8.0/11.0/18.0/22	26/30/50/68	4.0/7.0/20/28	9.0/13.0/37/53
H-40-160 Ø165	0.6/1.1/4.8/8	7.0/8.0/15.0/19	25/30/45/57	3.5/5.5/17.0/23	8.4/12.0/34/47
H-40-160 Ø155	0.5/0.9/4.0/6.5	6.0/7.0/12.5/15	23/28/43/55	3.0/4.7/13.0/18	7.3/10.7/30/42
H-50-160 Ø175	1.0/1.7/8.0/13.0	18.0/20/35/36	41/49/83/98	6.0/9.0/24/98	9.2/13.6/38/54
H-50-160 Ø165	0.9/1.5/6.8/11.2	15.0/18.0/27/32	38/47/79/95	5.5/8.2/22/95	8.4/12.4/35/49
H-50-160 Ø155	0.7/1.3/5.8/9.5	14.0/17.0/26/31	37/45/75/88	4.9/7.2/20/90	7.7/11.1/32/44
H-65-160 Ø175	1.8/3.0/13.2/22	36/44/73/80	78/93/157/184	5.2/7.6/21/30	8.6/12.5/35/50
H-65-160 Ø165	1.5/2.5/11.0/18.0	32/40/60/70	75/85/151/170	3.0/6.0/16.0/25	7.2/11.0/32/44
H-65-160 Ø155	1.3/2.1/8.8/15.0	25/32/50/60	70/78/141/165	1.5/4.5/9.0/15.0	6.2/9.2/27/38
H-50-200 Ø220	2.5/4.2/18.5/31	23/25/40/47	53/62/95/114	9.5/15.0/46/63	15.2/22/63/88
H-50-200 Ø205	2.1/3.5/15.5/26	20/22/35/40	50/58/90/108	9.0/13.5/42/57	14.0/20/57/80
H-50-200 Ø190	1.8/3.0/13.2/22	17.0/18.0/30/33	47/55/85/103	7.8/12.0/37/51	12.6/18/51/72
H-65-200 Ø220	3.3/5.8/27/44	37/45/76/86	90/105/182/200	9.0/14.0/37/57	15.0/22/61/86
H-65-200 Ø205	2.7/4.7/22/36	32/38/63/72	85/95/170/186	8.0/12.5/32/49	13.2/19.0/53/75
H-65-200 Ø190	2.2/3.7/17.5/29	23/27/46/52	77/90/157/172	7.0/10.5/28/42	11.6/16.8/47/66
H-80-200 Ø220	4.8/8.2/38/63	56/72/112/115	140/168/270/330	8.2/12.0/33/41	14.7/21/61/85
H-80-200 Ø205	3.9/6.7/31/51	50/60/95/105	130/156/260/300	7.1/10.4/27/38	12.7/18.5/53/73
H-80-200 Ø190	3.1/5.3/24/40	40/43/88/95	120/145/245/280	6.2/9.0/23/31	11.2/16.2/46/64

14. EU DECLARATION OF CONFORMITY

DESMI PUMPING TECHNOLOGY A/S, hereby declare that our pumps of the type Modular H Monobloc are manufactured in conformity with the following essential safety and health requirements in the COUNCIL DIRECTIVE 2006/42/EC on machines, Annex 1.

The following harmonized standards have been used:

EN/ISO 13857:2019	Safety of machinery. Safety distances to prevent danger zones being reached by the upper limbs
EN 809:1998 + A1:2009	Pumps and pump units for liquids – Common safety requirements
EN12162:2001+A1:2009	Liquid pumps – Safety requirements – Procedure for hydrostatic testing
EN 60204-1:2018	Safety of machinery – Electrical equipment of machines (item 4, General requirements)

Pumps delivered by us connected with prime movers are CE-marked and comply with the above requirements.

Pumps delivered by us without prime movers (as partly completed machinery) must only be used when the prime mover and the connection between prime mover and pump comply with the above requirements.

Nørresundby, September 20 2024



Henrik Mørkholt Sørensen
Managing Director

DESMI Pumping Technology A/S
Tagholm 1
9400 Nørresundby

15. INFORMATION RELEVANT FOR DISASSEMBLY OR DISPOSAL AT END-OF-LIFE

No damage materials are used in DESMI pumps – please refer to DESMI Green Passport (can be sent on request – contact a DESMI sales office) – i.e. common recycling companies can handle the disposal at end-of-life. Alternatively the pump and motor can be returned to DESMI at end-of-life for safe recycling.

16. ASSEMBLY DRAWING

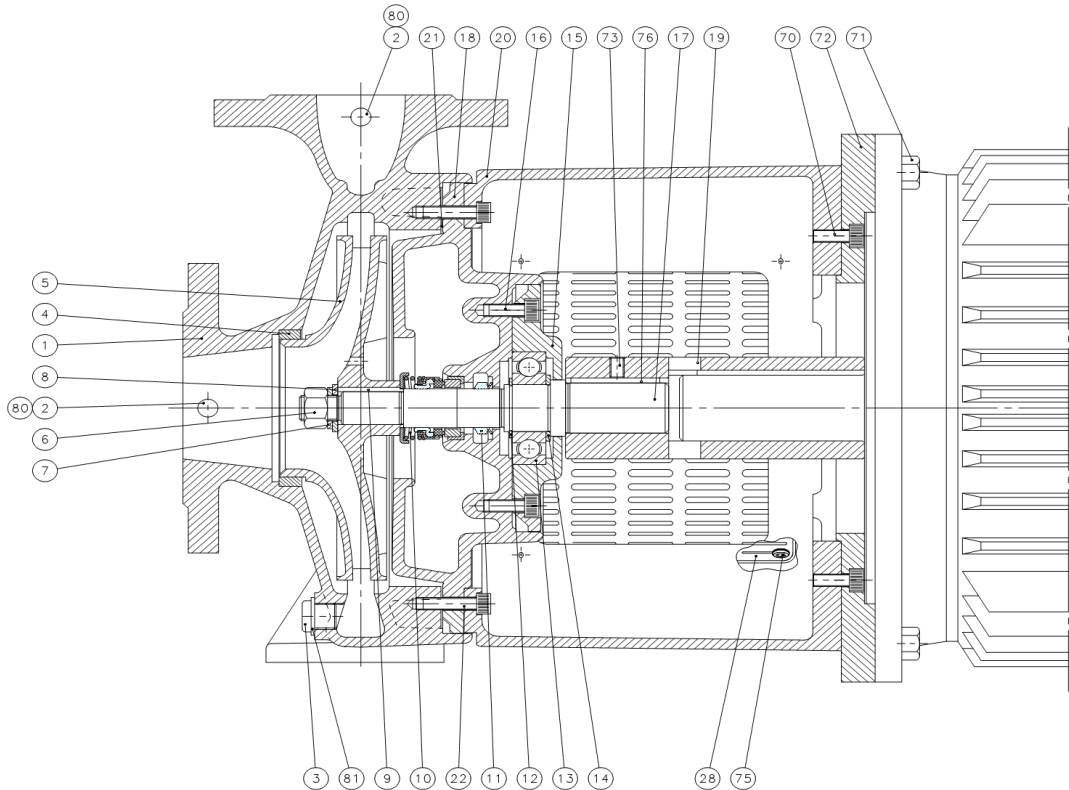

17. SPARE PARTS LIST

1 Pump casing	15 Bearing cover	75 INSEX-screw
2 Pipe plug	16 Allen screw	76 Sunk key
3 Pipe plug	17 Shaft	80 Sealing washer
4 Sealing ring	18 Shaft seal cover	81 Sealing washer
5 Impeller	19 Coupling	82 Sealing washer
6 Nut	20 Motor bracket	
7 Spring collar	21 Gasket	
8 Washer	22 Allen screw	
9 Sunk key	27 Pipe plug	
10 Mech. shaft seal	28 Guard	
11 Water deflector	70 Set screw	
12 Ring lock	71 Allen screw	
13 Ball bearing	72 Intermediate flange	
14 Support disc	73 Pointed screw	

18. DIMENSIONAL SKETCH

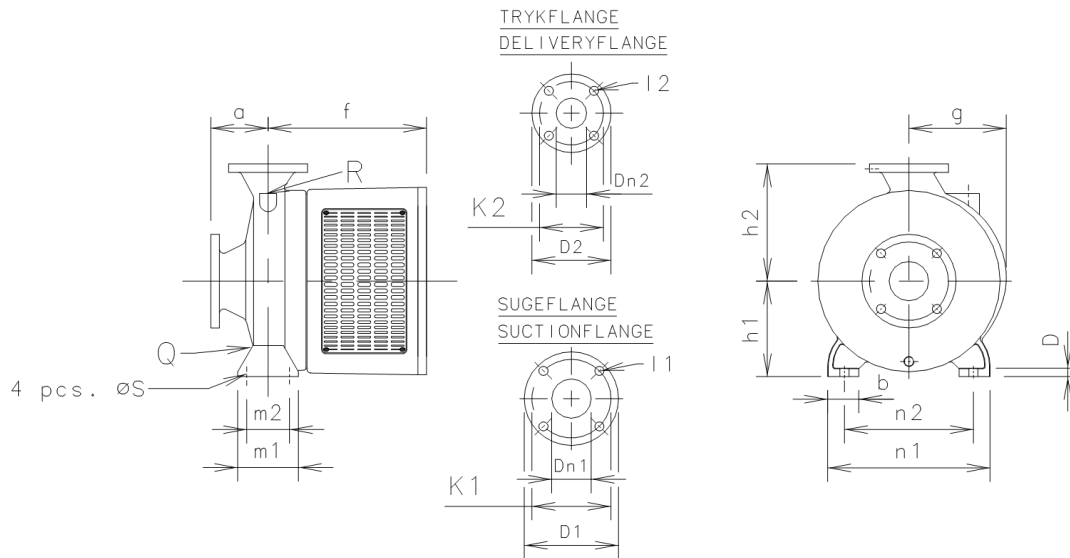

Type	m2	m1	n2	n1	b	D	S	h1	h2	l1
H-40-160	70	100	190	240	50	12	14	132	160	4x18
H-50-160	70	100	212	265	50	12	14	160	180	4x18
H-50-200	70	100	212	265	50	12	14	160	200	4x18
H-65-160	95	125	212	280	65	12	14	160	200	8x18
H-65-200	95	125	250	320	65	12	14	180	225	8x18
H-80-200	95	125	280	345	65	14	14	180	250	8x18

Type	l2	g	A	f	Dn1	K1	D2	Dn2	K2	Q	R	D1
H-40-160	4x18	125	80	284	65	145	150	40	110	1/4"RG	3/8"BSP	185
H-50-160	4x18	145	100	284	65	145	165	50	125	1/4"RG	3/8"BSP	185
H-50-200	4x18	160	100	288	65	145	165	50	125	3/8"RG	3/8"BSP	185
H-65-160	4x18	171	100	298	80	160	185	65	145	3/8"RG	3/8"BSP	200
H-65-200	4x18	185	100	288	80	160	185	65	145	3/8"RG	3/8"BSP	200
H-80-200	8x18	192	125	351	100	180	200	80	160	3/8"RG	3/8"BSP	220