

DESMI SA50T

- Self-priming centrifugal pump

This compact and simple to operate skimmer pump is ideal for use with the Terrapin weir system, and, combined they offer a portable and easy to operate system which can be used in many applications.

The DESMI SA50T is a light-weight pump especially designed for easy handling and operation onboard vessels. Manufactured from seawater resistant aluminium and tough stainless steel, the pump is coupled with a lightweight diesel engine. The unit is mounted on a stable carrying frame with handles for transportation. When in operation, the pump is able to self-prime within 20 seconds, allowing the system to begin skimming operations in very little time.

For ease of connection, the pump is offered with aluminium storz couplings on both the suction and pressure branches, which can easily be connected to standard 2" suction and discharge hoses.

The pump is suitable for both clean and polluted liquids, and can operate on liquids with temperatures between 0 and 80°C with no adverse effects. It will also deal with liquids with a range of viscosities of the liquids being pumped up to 300 cSt.



The DESMI SA50T is a single-stage self-priming centrifugal pump with stainless steel shaft. It uses a semi-open propeller to reduce the possibility of the pump choking during operation.

DESMI SA50T



DESMI
RO-CLEAN

DESMI

Advantages:

- Mounted on a strong yet stable frame to allow portability
- Stork C-2" Couplings for quick and easy connection of hoses
- Capacity of 24m³/Hr
- Casing manufactured from seawater resistant aluminium
- Compact and lightweight unit
- For use with clean and polluted liquids
- Simple but effective pump

TECHNICAL DATA

Dimensions: 0,68 x 0,42 x 0,62 m /
26.8 x 16.6 x 24.4 in

Max. pump rate: 24 m³ per hour / 105 US gpm @ 2.5 bar /
36.3 psi

Max. discharge pressure: 4 bar / 58 psi

Viscosity range: Up to 300 cSt

Temperature range: 0 to +80°C

Weight: 57 to 72 kg
(depending on engine and options)

Minimum manhole dia.: 380 mm / 15 in

Pump Inlet: 2" BSP female

Pump Outlet: 2" BSP female

Discharge connection: Storz C-2 on inlet and outlet or other types on request.

Standard Materials: Seawater resistant aluminium pump casing and stainless steel impeller.

DESMI SA50T

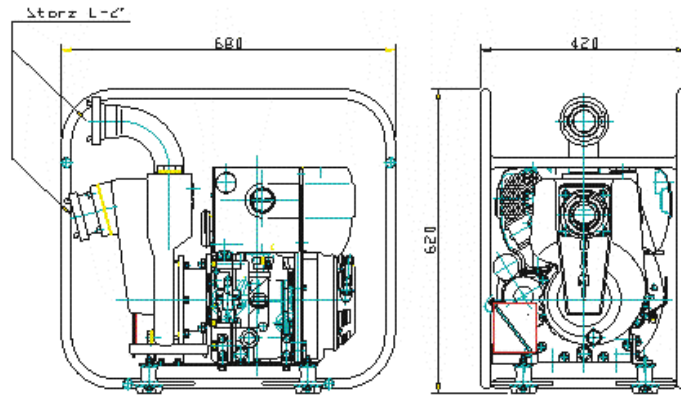

All information is subject to change, and pictures are for illustration purposes only, and not necessarily correct.

- Contact one of the offices below for further information

www.desmiro-clean.com



Head Office
DESMI Ro-Clean A/S
Hestehaven 61
DK-5260 Odense S
Phone: +45 65 48 16 10
Fax: +45 65 48 16 15
E-mail: Denmark.desmiro-clean@desmi.com

U.S.A. Office
U.K. Office
Latin America Office
Asia Office
China Office
Korea Office
Norway Office

APPLIED FABRIC TECHNOLOGIES INC, Tel.: +1 716 662 0632, E-mail: bestboom@afti.com
DESMI Ro-Clean Ltd, Tel. +44 23 80829751, E-mail: uk.desmiro-clean@desmi.com
DESMI Ro-Clean Latinoamerica S.A., Tel.: +593 2 326 1939, E-mail: Latinoamerica.desmiro-clean@desmi.com
DESMI Ro-Clean Asia, Tel.: +62 21 570 75 77, E-mail: asia.desmiro-clean@desmi.com
 DESMI Ro-Clean, DESMI Pumping Technology (Suzhou) Co., Ltd., Tel.: +86 512 6274 0400, E-mail: China.desmiro-clean@desmi.com
DESMI Ro-Clean, DESMI Korea, Gyeonggi, Tel.: +82 31 931 5701, E-mail: Korea.desmiro-clean@desmi.com
DESMI Ro-Clean, DESMI Norge AS, Kristiansand S, Tel.: +47 3812 2180, E-mail: Norway.desmiro-clean@desmi.com