

OPERATION AND MAINTENANCE INSTRUCTIONS

DESMI priming pump B114N

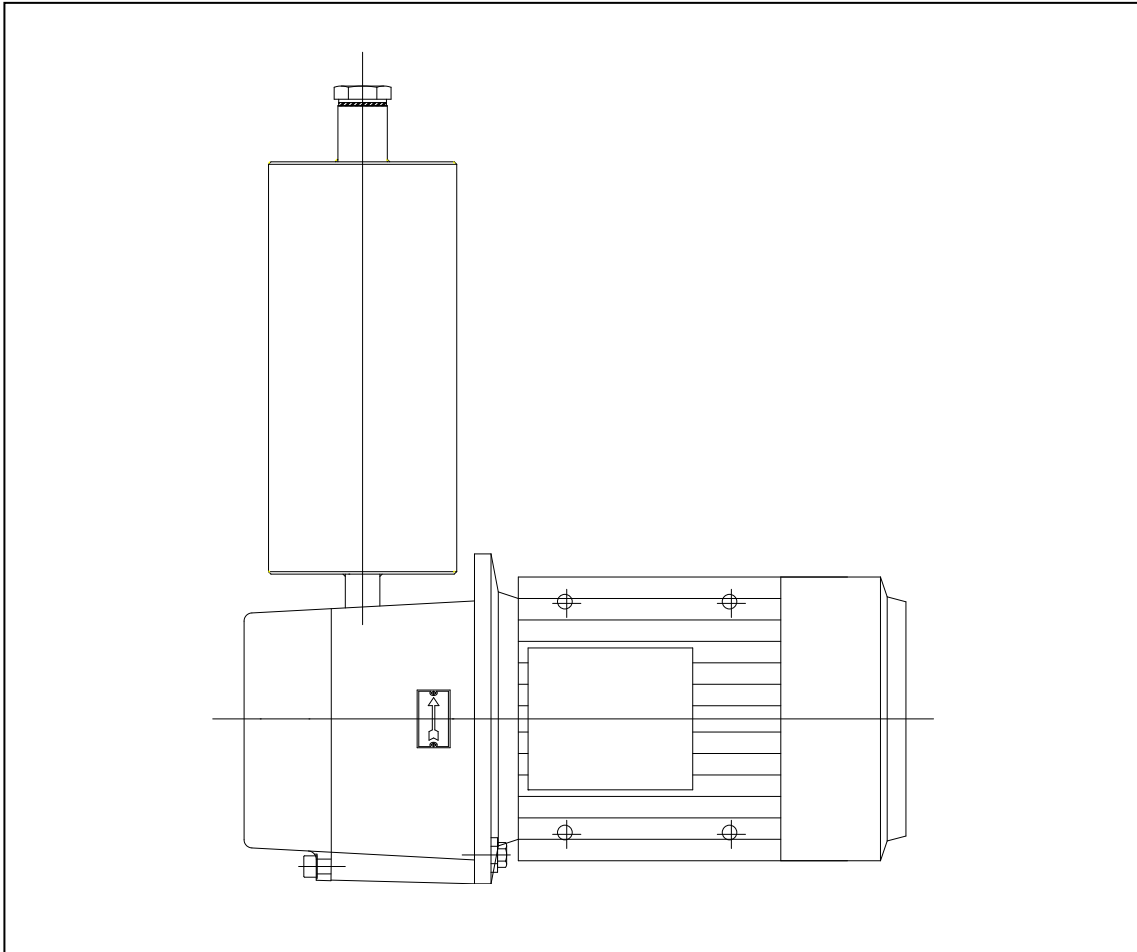

DESMI A/S

Tagholm 1 – DK-9400 Nørresundby – Denmark

Tel.: +45 96 32 81 11

Fax: +45 98 17 54 99

E-mail: desmi@desmi.com

Internet: www.desmi.com

Manual: T1488	Language: English	Revision: B (06/10)
------------------	----------------------	------------------------

Special pump No.

TABLE OF CONTENTS	PAGE
1. PRODUCT DESCRIPTION	3
1.1 DELIVERY	3
2. TECHNICAL DATA	3
2.1 EXPLANATION OF THE NAME PLATE	3
2.2 TECHNICAL DESCRIPTION.....	3
3. INSTALLATION	4
3.1 WIRING.....	4
4. TRANSPORT/STORAGE.....	4
5. DISMANTLING	4
5.1 ACCESS TO IMPELLER	4
5.2 SHAFT SEAL	4
5.3 INSPECTION	5
6. ASSEMBLING.....	5
6.1 FITTING SHAFT AND SHAFT SEAL.....	5
6.2 FITTING IMPELLER.....	5
6.3 SHAFT	5
7. FROST PROTECTION	5
8. DISMANTLING	6
9. START-UP	6
9.1 STARTING.....	6
10. INSPECTION AND MAINTENANCE	7
11. REPAIRS	7
11.1 ORDERING SPARE PARTS	7
12. OPERATING DATA	7
13. EU DECLARATION OF CONFORMITY	8
14. ASSEMBLY DRAWING B114N.....	9
14.1 SPARE PARTS LIST B114N.....	9
15. DIMENSIONAL SKETCH.....	10

1. PRODUCT DESCRIPTION

These maintenance and operation instructions apply to the DESMI priming pumps B114N. The pumps have 1/2" connections on suction and pressure side. B114N is a vacuum pump of the water ring type, with mechanical shaft seal, bronze shaft, star wheel, and pump casing.

Max. temperature for standard type is 80°C.

The pumped liquid serves as lubricant for the pumps and therefore, they do not have to be lubricated further.

Max. number of revolutions is 3600 RPM. The pump is driven by an electric motor, which may be a standard AC motor, or a DC motor.

1.1 DELIVERY

- Check on receipt that the delivery is complete and undamaged.
- Defects and damages, if any, to be reported to the carrier and the supplier immediately in order that a claim can be advanced.

2. TECHNICAL DATA

2.1 EXPLANATION OF THE NAME PLATE

The pumps are equipped with a name plate indicating pump type, production week, production year, item list number if the pump has been sold alone, or an order number, if the pump has been sold when built together with another machine.

Before putting a pump into operation, the suitability of the material combination of the pump must always be taken into consideration. In case of doubt, contact the supplier.

If the pumps are intended for special purposes the following is to be indicated:

Pump No. : _____
 Pump type : _____
 Application : _____
 Comment : _____

2.2 TECHNICAL DESCRIPTION

The noise level indicated is the airborne noise including the motor. The noise depends on the motor type supplied, as the noise from the pump can be calculated as the noise level of the motor + 2dB(A). This noise level applies to pumps with electric motors.

The permissible loads on the flanges on suction and pressure side are stated in the table below:

Pump	Fv(N)	Fh (N)	∑ F(N)	∑ Mt (Nm)
B114N	500	400	640	80

F_v : The max. permissible sum of the vertical forces on the two connections.

F_h : The max. permissible sum of the horizontal forces on the two connections.

$\sum F$: The vectorial sum of the two forces F_v and F_h .

$\sum M_t$: The max. permissible sum of torques on the two connections.

In connection with the permissible loads on the connections stated in the above table the following is to be observed:

$$\left(\frac{\sum F_{calc}}{\sum F} \right)^2 + \left(\frac{\sum M_{calc}}{\sum M_t} \right)^2 < 2 \quad \text{where index "calc" is the values calculated by the user.}$$

3. INSTALLATION

The max. permissible loads on the connections stated in paragraph 2.2 must be observed.



At installations pumping hot or very cold liquids the operator must be aware that it is dangerous to touch the pump surface and he is to take the necessary safety measures.

3.1 WIRING



Wiring to be carried out by authorized skilled workmen according to the rules and regulations in force.

4. TRANSPORT/STORAGE

The weight, including DESMI motor, is indicated in the table below:

Type	Weight in kg
B114N/50 Hz	30
B114N/60 Hz	31

The pump is to be stored in a dry area.

5. DISMANTLING

The numbers in brackets refer to the position numbers on the assembly drawing.

5.1 ACCESS TO IMPELLER

Remove Allen screws (12) and dismantle the end cover (3). Remove the pointed screw (7). The impeller (1) can now be pulled off and inspected.

5.2 SHAFT SEAL

Remove key (11) from the shaft (4). Remove the copper pipes (16) and (27) connected to the pump casing. Remove set screws (14) and pull the pump casing free of the shaft (4) and the electric motor and the shaft seal is pulled off the shaft.. Press the seat out from behind the pump casing.

5.3 INSPECTION

After dismantling as described in 5.1, inspect the impeller, end cover and pump casing. Replace the parts, if wear or corrosion is established in areas to such an extent that the priming ability of the pump is considerably deteriorated, or the pump makes more noise than usual. Check the seat in the shaft seal for flatness and cracks. Check rubber parts for elasticity.

6. ASSEMBLING

6.1 FITTING SHAFT AND SHAFT SEAL

Fit the shaft (4) on the motor shaft. The motor shaft must entirely bottom the hole in the shaft (4). Fit and tighten the pointed screws (6) (first the middle screw). Check that the wobble of the shaft, measured as far as possible from the motor, does not exceed 0.07 mm (70 µm).

Fit the sealing washer (9) in the pump casing. Fit the pump casing on the motor with screws and washers (14).

Please note which type of rubber is used in the shaft seal bellows. As standard the material is nitrile, but it might be EPDM which will be damaged by mineral grease. Use soft soap or silicone grease for EPDM. Before fitting the seat, clean the recess in the cover. Dip the outer rubber ring of the seat in soapy water or grease it with silicone. Now press the seat into place with the fingers and check that all parts are correctly imbedded. If it is necessary to use fitting tools, then protect the sliding surface of the seat to prevent it from being scratched or cut. Lubricate the inner diameter of the rubber bellows on the slide ring with soapy water and push it over the shaft.

Push the slide ring over the shaft with the hand. If the rubber bellows is tight, use a fitting tool and take care that the slide ring is not damaged. If the carbon ring is not fixed, it is important to check that it is fitted correctly, i.e. the chamfered/lapped side is to face the seat. The carbon ring can be held by a little grease. When using soapy water on the shaft, the bellows will settle and seat in about 15 minutes and until then tightness should not be expected. After start, check by viewing the leak hole that there are no leaks.

6.2 FITTING IMPELLER

Fit the key (11) in the shaft and lead the impeller over the shaft. Use an air gap gauge to place the impeller 0.05 mm from the pump casing when tightening the pointed screw (7). Fit the end cover and O-ring (13) with Allen screws (12). Fit the copper pipes (16) and (27) connected to the pump casing.

6.3 SHAFT

When the pump has been assembled, check that the shaft rotates freely and without noise.

7. FROST PROTECTION

Pumps which are not in operation during frost periods are to be drained to avoid frost damage. Alternatively, it is possible to use anti-freeze liquids in normal constructions.

8. DISMANTLING



Before dismantling the pump make sure that it has stopped. Empty the pump of liquid before it is dismantled from the piping system. If the pump has been pumping dangerous liquids you are to be aware of this and take the necessary safety measures.

If the pump has been pumping hot liquids, take great care that it is drained before it is removed from the piping system.

9. START-UP

The pump will not function until the feed water tank has been filled with liquid.



The liquid also serves as coolant for the shaft seal. In order to protect the shaft seal the pump must not run dry.

9.1 STARTING

Before starting the pump check that

- the shaft rotates freely without jarring sounds.
- the feed water tank is filled with liquid.

Start the pump for a moment to check the direction of rotation. If the direction is correct (i.e. in the direction of the arrow), the pump may be started. Should the pump not function as intended, please proceed according to the fault-finding list. Bear in mind, though, that the pump was carefully checked and tested at the factory and that the majority of faults stem from the piping system.

FAULT	CAUSE	REMEDY
The priming pump has no or too low capacity	<ol style="list-style-type: none"> 1. Wrong direction of rotation 2. Piping system choked 3. The pump is choked 4. Suction line leaks 5. Suction lift too high 6. No water in the feed water tank 7. The pump is unable to discharge air into the delivery piping. 	<p>Change direction of rotation to the direction of the arrow Clean or replace Clean the pump. Check the copper pipe between feed water tank and pump, and all fittings on the pump Find the leakage, repair the fault. Note: a pressure-tight piping system is not necessarily vacuum-tight. Check data sheet Q/H or contact DESMI Fill the feed water tank with water The piping system must be designed so that air can easily escape. A vertical pipe filled with water reduces the airflow considerably.</p>

FAULT	CAUSE	REMEDY
The priming pump uses too much power	1. Foreign body in pump 2. Electric motor is running on 2 phases	Dismantle the pump, remove the cause Check fuses, cable connection and cable

10. INSPECTION AND MAINTENANCE

Inspect the shaft seal in B114N for leaks at regular intervals.

- Before any inspection of a pump without guard check that the unit cannot be started unintentionally.
- The system is to be without pressure and drained of liquid.
- The repairman must be familiar with the type of liquid which has been pumped as well as the safety measures he is to take when handling the liquid.

11. REPAIRS

11.1 ORDERING SPARE PARTS

When ordering spare parts please always state pump type and pump No. (indicated on the name plate of the pump). See also spare parts drawing with item Nos and part names. See assembly drawing.

12. OPERATING DATA

The powers indicated in the table below constitute the max. power consumption of the pump. The following working pressures are allowed:

TYPE	PRESSURE bar	Power kW
B114N	2	2,6

13. EU DECLARATION OF CONFORMITY

DESMI A/S, hereby declare that our pumps of the type B114N are manufactured in conformity with the following essential safety and health requirements in the COUNCIL DIRECTIVE 2006/42/EC on machines, Annex 1.

The following harmonized standards have been used:

EN 294:1994	Safety of machinery. Safety distances to prevent danger zones being reached by the upper limbs
EN 809 + A1	Pumps and pump units for liquids – Common safety requirements
EN 12162:2001	Liquid pumps – Safety requirements – Procedure for hydrostatic testing
EN 60204-1:2006	Safety of machinery – Electrical equipment of machines (item 4, General requirements)

Pumps delivered by us connected with prime movers are CE-marked and comply with the above requirements.

Pumps delivered by us without prime movers (as partly completed machinery) must only be used when the prime mover and the connection between prime mover and pump comply with the above requirements.

Nørresundby, June 1, 2010



Kurt Bech Christensen
Technical Director

DESMI A/S
Tagholm 1
9400 Nørresundby

14. ASSEMBLY DRAWING B114N

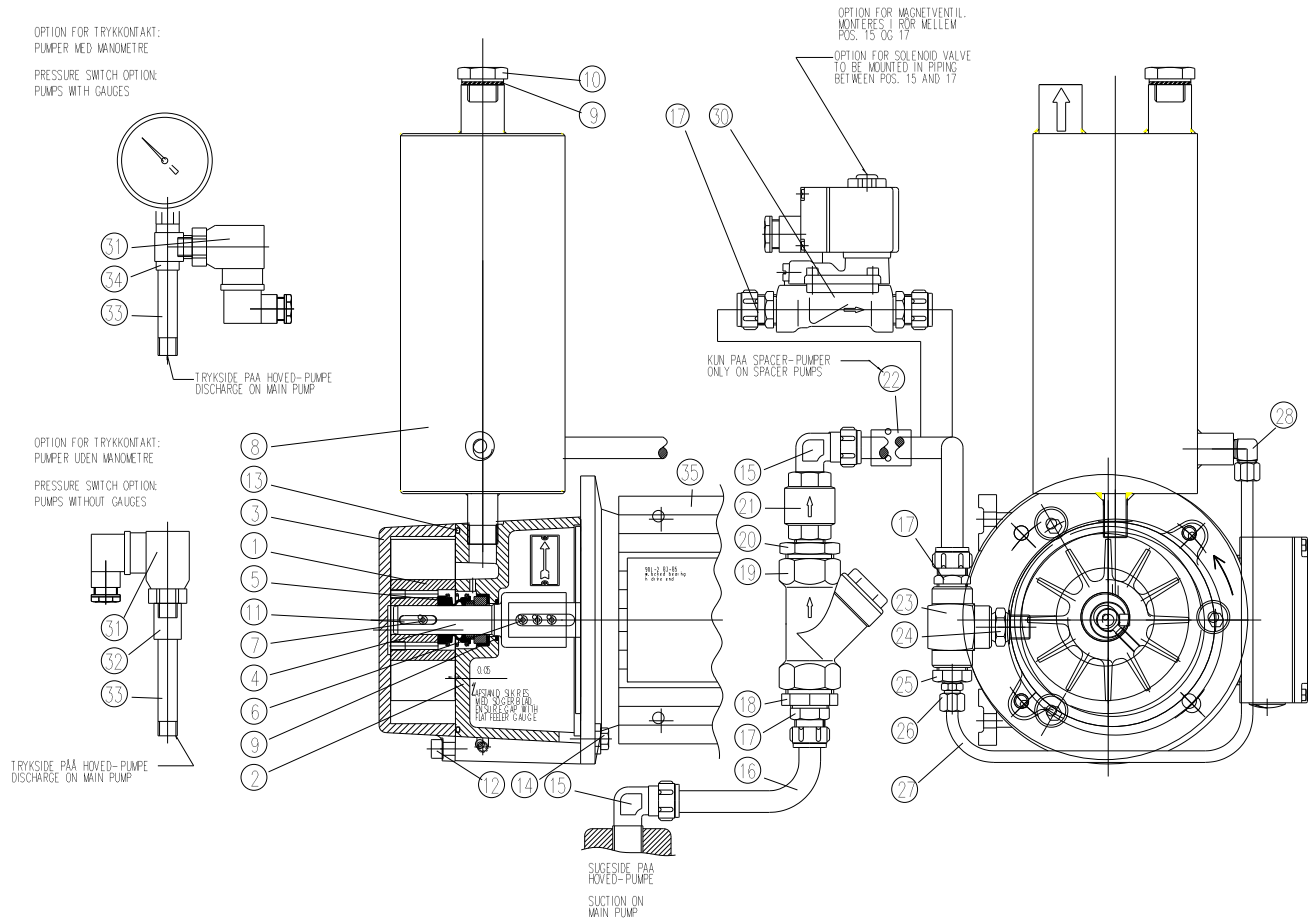

14.1 SPARE PARTS LIST B114N

1	Impeller	14	Set screw/washer	27	Copper pipe
2	Pump casing	15	Angle nipple	28	Angle nipple
3	End cover	16	Copper pipe	29	Fitting
4	Shaft	17	Hexagon nipple	30	Magnetic valve *
5	Shaft seal	18	Bushing	31	Pressure switch
*					
6	Pointed screw	19	Filter	32	Muff
7	Pointed screw	20	Hexagon nipple	33	Nipple
8	Feed water tank	21	Nonreturn valve	34	Muff-tee
9	Sealing washer	22	Pipe clamp	35	Motor
10	Pipe plug	23	Muff-tee		
11	Key	24	Hexagon nipple		
12	Allen screw	25	Red. nozzle		
13	O-ring	26	Hexagon nipple		

*) OPTION

15. DIMENSIONAL SKETCH

