

INSTALLATION, OPERATION AND MAINTENANCE INSTRUCTIONS

DESMI Vertical Turbine Pumps

Type DESLUBE-N

DESMI PUMPING TECHNOLOGY A/S

Tagholm 1 – DK-9400 Nørresundby – Denmark



Tel.: +45 96 32 81 11
Fax: +45 98 17 54 99
E-mail: desmi@desmi.com
Internet: www.desmi.com

Manual: T1518	Language: English	Revision: J(09/24)
---------------	----------------------	-----------------------



Special pump No.

CONTENTS

CONTENTS	2
1. PRODUCT DESCRIPTION	3
2. TECHNICAL DATA	3
2.1 EXPLANATION OF THE TYPE NUMBER	3
2.2 TECHNICAL DESCRIPTION.....	3
3. TRANSPORT, STORAGE AND DELIVERY	4
3.1 TRANSPORT	4
3.2 STORAGE.....	4
3.3 DELIVERY	4
4. INSTALLATION	5
4.1 MOUNTING/FASTENING	5
4.2 WIRING.....	5
4.3 ASSEMBLY DIMENSIONAL DRAWING	5
5. INSPECTING THE PUMP	5
5.1 INSPECTION	5
5.2 SHAFT ADJUSTMENT	5
6. SYSTEM BALANCING.....	6
7. PREPARATION FOR STARTING	6
8. STARTING AND MAINTANENCE.....	6
9. STOPPING	7
10. DISMANTLING.....	7
10.1 Dismantling top parts	7
10.2 Dismantling bowl unit.....	11
10.3 ASSEMBLY.....	16
11. TROUBLE SHOOTING	17
12. REPLACEMENT OF WEAR PARTS.....	18
12.1 WEAR RING REPLACEMENT.....	18
12.2 REPLACEMENT OF GUIDE BEARING AND SLEEVE	18
12.3 REPLACEMENT OF SEALING RINGS.....	18
13. EU DECLARATION OF CONFORMITY	19
14. INFORMATION RELEVANT FOR DISASSEMBLY, RECYCLING OR DISPOSAL AT END-OF-LIFE	19

1. PRODUCT DESCRIPTION

These operation and maintenance instructions apply to the DESMI Deslube-N pump series. DESMI Deslube-N is a multi-stage centrifugal pump with thrust bearing unit. The pump is further equipped with a closed impeller. The pump is designed only for pumping lubricating oils with temperatures between 0 and 80°C.

When pump serves for main engine oil lubrication and is ceramic coated, a proper filter shall be installed in the piping system to protect the main engine. This is to consider in case there is coating material peeled off and enter the main engine. ⚠

2. TECHNICAL DATA

The pumps are manufactured in various material combinations which appear from the type number on the name plate. See below.

2.1 EXPLANATION OF THE TYPE NUMBER

All the Deslube-pumps are provided with a name plate. The type number indicated on the name plate is built up as follows:

DL XXXH-SN /MR

XXX : Bowl outside diameter
H : Hydraulic model
S : Number of stages N
 : Inner oil lubrication
M : The material combination of the pump
R : The assembly combination of the pump

M may be the following:

A : Standard. Casing: GG20. Impeller/wear ring: NiAlBz Standard
B : Standard. Casing: GG20. Impeller/wear ring: Stainless steel.
C : All cast iron.
D : Casing: RG5. Impeller/wear ring: NiAlBz
E : Special bronze casing and/or impeller
The pumps are available in other material combinations at request.

R may be the following:

09: With bare shaft end.
12: Flange-mounted with electric motor. Standard

No code M hint A, No code R hint 12

Before putting a pump into operation, the suitability of the material combination of the pump must always be taken into consideration. In case of doubt, contact the supplier.

If the pumps are designed for special purposes the following is to be indicated:

Pump No. :
Pump type :
Application :
Comment :
Other requirements:

2.2 TECHNICAL DESCRIPTION

The noise level from the pump depends on the motor type supplied, as the noise from the pump can

be calculated as the noise level of the motor + 2dB (A). The noise level of the motor appears from the instruction manual for the motor. The pump performance data appears on the nameplate of the pump.

3. TRANSPORT, STORAGE AND DELIVERY

3.1 TRANSPORT

Lift the pump by placing the rope around it and see to it that the pump is balanced.

The rope must not bear against sharp edges and corners.

Lifting eyes might be mounted in the pump and used instead.

Before shipment the pump is to be fastened securely on a pallet or the like.

3.2 STORAGE

After platform testing, every pump is drained and an internal corrosion-resistant protection is applied (except for pumps in bronze material or specific conditions). However, we recommend that the pump is always stored indoors and in a dry area – e.g. packed in plastic sheeting and equipped with moisture-absorbent Silica Gel bags.

a. Short-term storage, less than three months

(1) Storage area must be reasonably level, stable ground not subject to flooding.

(2) the equipment will have to be stored in a dry location and free from vibrations

(3) Small pumps shipped in package may be stored as received, provide the skids have not been damaged in transit.

(4) For big pump, the suction and discharge openings should be checked to ensure closed to prevent dirt, animals or vandals from entering.

(5) For the duration not exceeding three months. Moreover, it is advised to turn the pump shaft over manually and periodically to avoid any risks of seizing of mobile parts.

b. Long-term storage

If the storage duration exceeds three months, in addition to the precautionary measures specified in a, it is necessary to coat with rust preventative adequate for all exposed machined surfaces (consult your lubrication specialist) and re-apply the preserving fluid in pump casing every three months. Make sure that the product used is compatible with the pump materials and complies with the environmental protection and personnel safety regulations currently in force.

c. Coating & Recommended anticorrosion

Coat the pump by spraying anticorrosion oil through both input and output branches e.g. by means of pressure air every year. Recommended anticorrosion oil is Q8 Ravel D, Shell Ensis PX / EX, Mobilarma 777 or similar oil. Also a neutral oil as e.g. a hydraulic oil can be used. If pumps are mounted in a piping system, the coating can be sprayed through manometer holes on input and output branches.

3.3 DELIVERY

- Check on receipt that the consignment is complete and undamaged.
- Defects and damages, if any, are to be reported to the carrier and the supplier immediately in order that a claim can be advanced.

4. INSTALLATION

4.1 MOUNTING/FASTENING

The pump should be mounted on a sturdy base plate with a flat and horizontal surface to avoid distortion.

- Avoid distortion of the base plate.
- Avoid distortion of the piping system.
- Check carefully that pump and motor are accurately aligned.
- Shaft can easy rotate without any noise.



At installations pumping hot or very cold liquids, the operator must be aware that it is dangerous to touch the pump surface and, consequently, he must take the necessary safety measures.

4.2 WIRING



Wiring to be carried out by authorised skilled workmen according to the rules and regulations in force.

4.3 ASSEMBLY DIMENSIONAL DRAWING

Assembly dimensional drawing will be sent to the customer for each pump type. And the product will be consistent with dimension drawing.

5. INSPECTING THE PUMP

Before any inspection of the pump, check that the unit cannot be started unintentionally.



- The system is to be without pressure and drained of liquid.
- The repairman must be familiar with the type of liquid, which has been pumped as well as with the safety measures he has to take when handling the liquid.
- Inspect the shaft seal for leaks at regular intervals.

5. INSPECTING THE PUMP

5.1 INSPECTION

When the pump has been dismantled, check the following parts for wear and damage:

- Shaft seal/sealing seat : Check seat for flatness and cracks.
Check rubber parts for elasticity.
- Bearings : Replace in case of wear and noise.

5.2 SHAFT ADJUSTMENT

When the pump has been assembled, check that the shaft rotates freely; if necessary adjust the axial clearance by turning the lock nut on the up-shaft. The axial raise is **2~4mm**. Don't raise shaft too much so that pump shaft can't rotate freely.

6. SYSTEM BALANCING

It is often difficult to calculate a delivery head in advance. It is, however, decisively important to the

capacity of liquid delivered.

A considerably smaller delivery head than expected will increase the capacity of liquid delivered, causing increased power consumption.

Therefore, after start-up, it is necessary to check either the capacity of liquid delivered or the power consumption of the pump e.g. by measuring the current intensity of the connected motor. Together with a reading of the differential pressure the capacity of water delivered can be determined against the characteristics of the pump.

Should the pump not function as intended, please proceed according to the fault-finding list. Bear in mind, though, that the pump was carefully checked and tested at the factory and that the majority of faults stem from the piping system.

7. PREPARATION FOR STARTING

- 7.1 Check motor rotating direction with the pins by starting up for a short while. It is recommended that the electrical connection and rotating direction check be carried out prior to connecting with pump.
- 7.2 The rotor shall rotate freely by turning it at the coupling without any noise
- 7.3 Check if the liquid level in tank or well meets the submersible depth requirement for the pump.
- 7.4 Check if motor control and protection system are reliable.

The pump is not warranted for pumping foreign material in the liquid.

8. STARTING AND MAINTANENCE

- 8.1 Set the discharge valve at nearly closed position.
- 8.2 Ensure liquid level is higher than min. liquid level requirement.
- 8.3 Start the pump; open the discharge valve slowly to avoid overheating/pressure.
- 8.4 The pump shall be stopped and checked as soon as one of the following phenomena occurs:
 1. Current exceeds the specified value or fluctuates widely;
 2. Obvious vibrations and noise.
 3. Bearing temperature or motor winding temperature exceeds the value specified in the documents provided with the equipment.
- 8.5 The operator shall pay attention to the follows during normal operation:
 1. Check and record the operating conditions, such as current, voltage, discharge pressure and capacity daily.
 2. Check for leakage daily.

9. STOPPING

- 9.1 Shut-off the power supply for motor.
- 9.2 Close discharge valve.

10. DISMANTLING



Before dismantling the pump make sure that it has stopped. Empty the pump of liquid before it is dismantled from the piping system. If the pump has been pumping dangerous liquids you are to be aware of this and take the necessary safety precautions.

If the pump has been pumping hot liquids, take great care that it is drained before it is removed from the piping system.

In DL 300/300B/400 pump, if you want to dismantle bowl unit, you have to dismantle the head unit first. **But in DL 500&350&350B pump, the bowl unit can be dismantled from bottom.**

10.1 Dismantling top parts

If only bearing unit is necessary to be dismantled, motor and pump will not need to be lifted. It brings much convenience in maintenance.

Take DL400-2N for example :

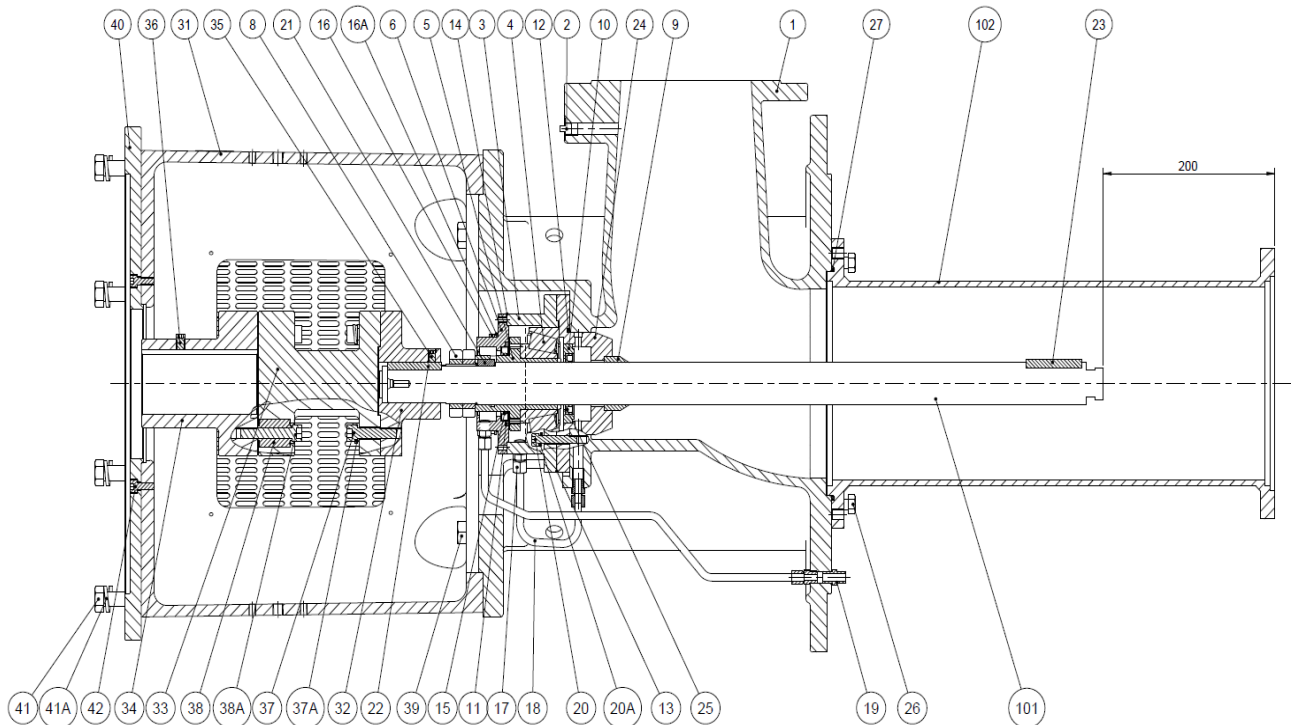

No.	Description	Quantity	No.	Description	Quantity
1	Head 10" x 8" FOR DL400	1	25	Oil Seal Ring AS 45x65x8 FPM	1
2	PLUG W.4K 1/4" BSPT A4	1	26	Set Screw M16x45 Blackoxide	12
3	Bearing House	1	27	O-Ring Ø320x5.3 Nitril GB3452	1
4	Conical Roller Bearing	1	28	HEX.NIPPLE W/SL. 1/2"X15 BRASS	2
5	Supporter	1	29	PIPE COPPER 15X1 HARD	0.4
6	Bearing Cover	1	31	Mot. Bracket	1
8	Lock Nut M42x1.5	2	32	Pump Coupling	1
9	Throat ring	1	33	Spacer Coupling	1
10	Second Ring	1	34	Motor Coupling	1
11	TOP RING FOR DL PUMP	1	35	Point Screw M8x12 45H DIN916	1
12	O-Ring 110.72x3.53	1	36	Point Screw M10x16 45H DIN916	1
13	Oil Paper Gasket Ø190x Ø140x0.2	1	37	Allen Screw M12x45 ST8.8 FZB	8
14	Oil Paper Gasket Ø150x Ø126x0.2	1	37A	SPRING WASHER M12 FZB	8
15	Seal Ring 60x80x8 AS FPM	1	38	Coupling Bush Ø30x12x40	8
16	Allen Screw M6 A4 DIN912	4	38A	ALLEN SCREW M12X60 ST8.8	8
16A	SPRING WASHER M8	4	39	Set Screw M16x40 FZB	4
17	Hex Nipple W/SL 1/4"x Ø8 Brass	4	40	Inter. Flange 250/280 ST37.2	1
18	Tube Copper 8x1.0	1	41	Set Screw M16x40 A4 &	8
19	Hex Nipple W/SL 1/4"x 1/4"BSP Brass	1	41A	Spring Washer M16 A4	8
20	ALLEN SCREW M8X45	4	42	Allen Screw M8x20 ST8.8 FZB	8
20A	Spring Washer M8 A4 DIN127B	4	43	GUARD F.B5 MONOBL.CONST.ST37.2	2
21	Key A 8x7x20 ST60.11	1	44	HEX HEAD FL. BOLT M5X10 ST10.9	8
22	Key A 12x8x63 ST60.11	1	101	Deslube Top Shaft	1
23	Key A 14x9x65 1.4571	1	102	DL Column 8"	1
24	PACKING BOX	1			

1. Loosen the allen screws and washer (37)&(37A),(38)&(38A)



2. Remove the spacer coupling (33)

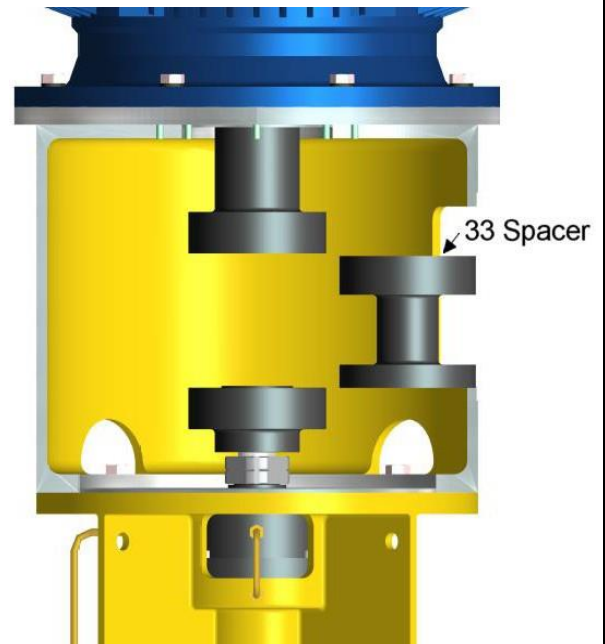

3. Loosen the point screw (35) and remove the pump coupling (32) and key (22)



4. Unscrew the shaft nut (8)



5. Loosen the allen screw (16) and remove the bearing cover (6) and oil seal (15)



6. Unscrew the hex-nipple (17) and remove the pipe (18)

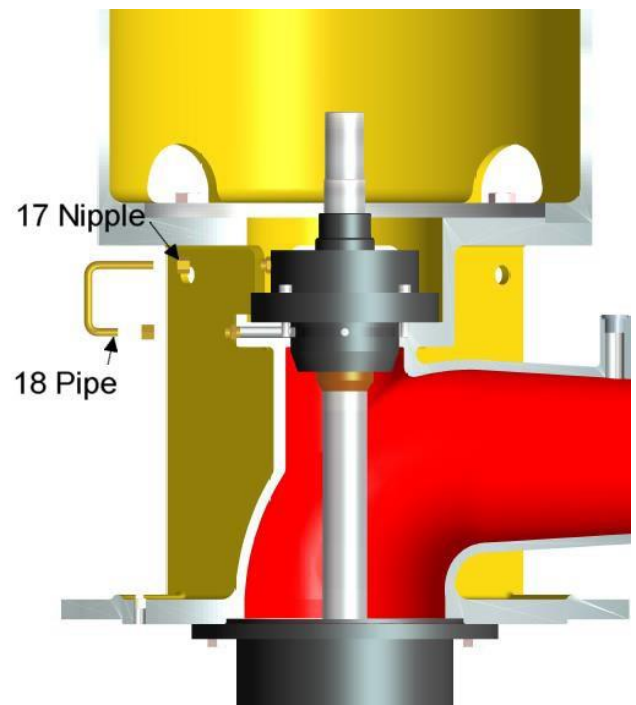

7. Pull out the bearing supporter (5) with bearing (4) along the shaft, and remove the key (21)



8. Loosen the allen screw (20) and take off the bearing house (3)

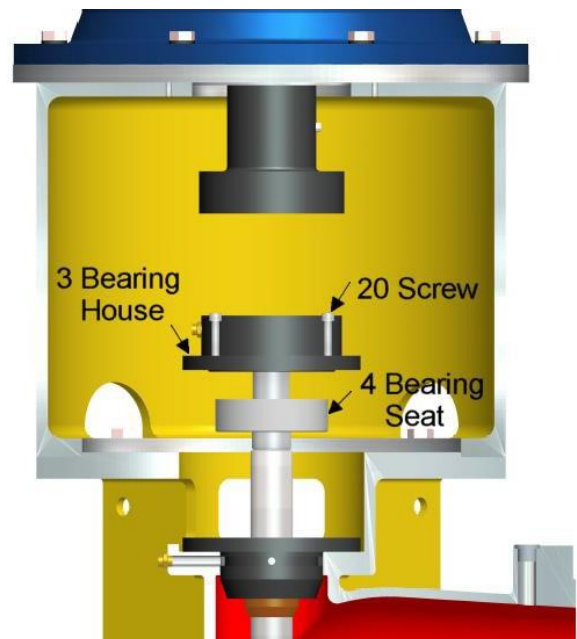

9. Pull out the packing box (24)

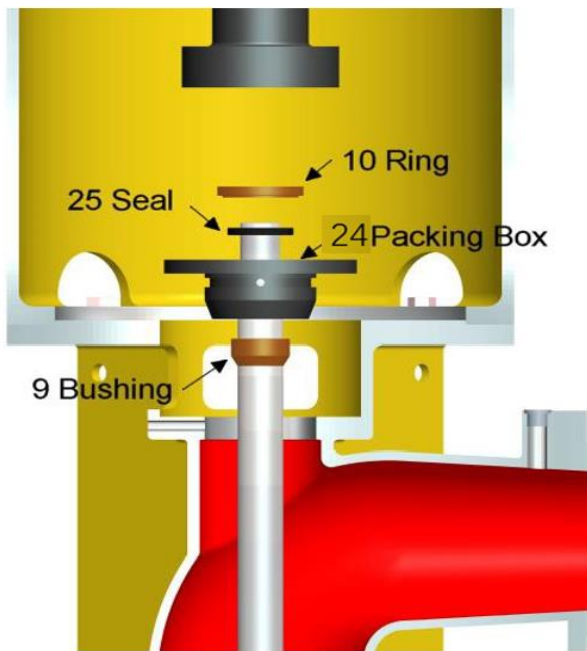

10.2 Dismantling bowl unit

Take DL400-2N for example (DL300/300B/400 have the same way to dismantle bowl unit):

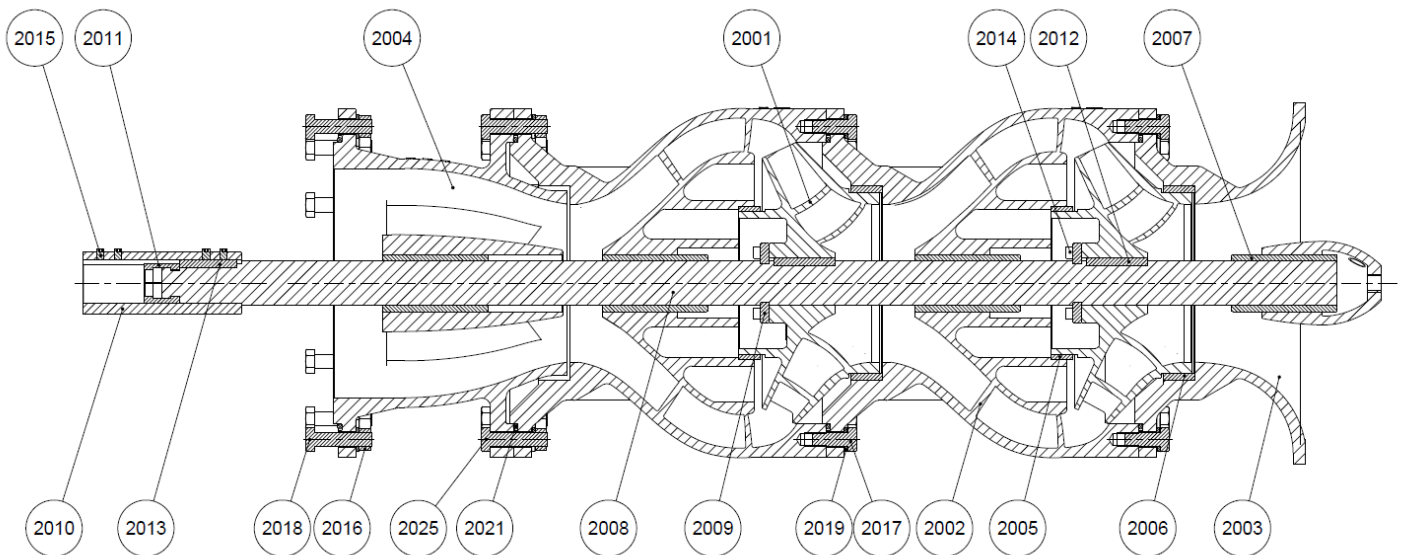

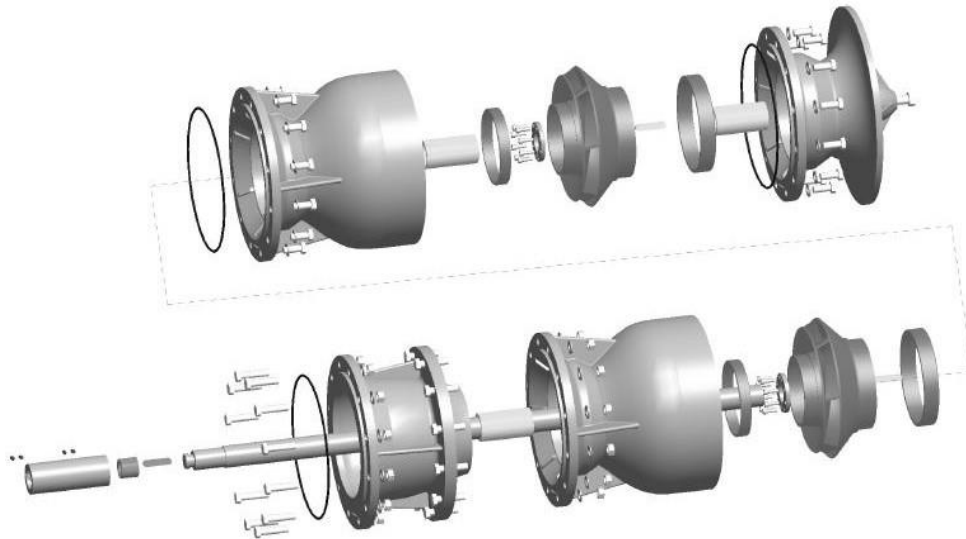

No.	Description	Quantity	No.	Description	Quantity
2025	SET SCREW M16X70 DIN933	12	2010	Half coupling Ø45	1
2021	O-ring 320x5.3 GB/T3452.1	4	2009	Lock ring Ø50	2
2019	Washer M16 Din127	48	2008	Bowl shaft, 2 stages	1
2018	Set Screw M16X65 Din 933	12	2007	Bearing Ø50X120	4
2017	Set Screw M16X40 Din 933	24	2006	Wear ring 205	2
2016	Nut M16	24	2005	Back wear ring 162	2
2015	Point screw M8X12 Din916	4	2004	Discharge Case 400/10"	1
2014	Allen Screw M8X25	16	2003	400 Bell	1
2013	Key 14X9X65	1	2002	400 Bowl	2
2012	Key 14X9X70	2	2001	400 Impeller	2
2011	Half connector	1			

1. Loosen the set screw (2025) and nut (2016), then remove the discharge case (2004)

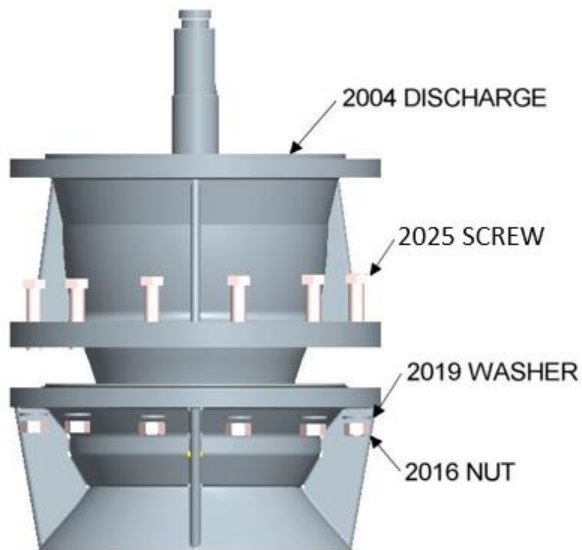

2. Loosen the set screw (2017) and remove the bowl (2002)

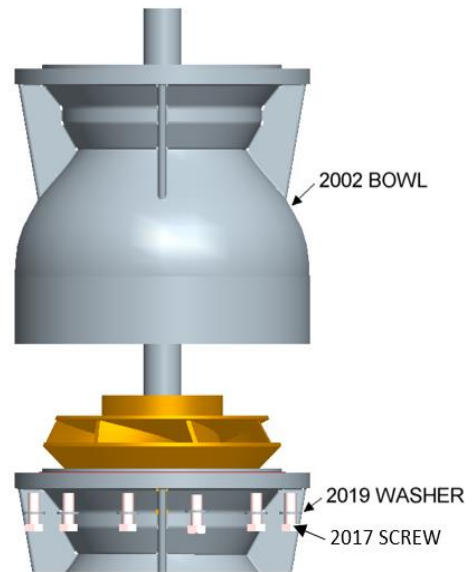

3. Loosen the allen screw (2012) and remove the lock ring (2009) and impeller (2001)

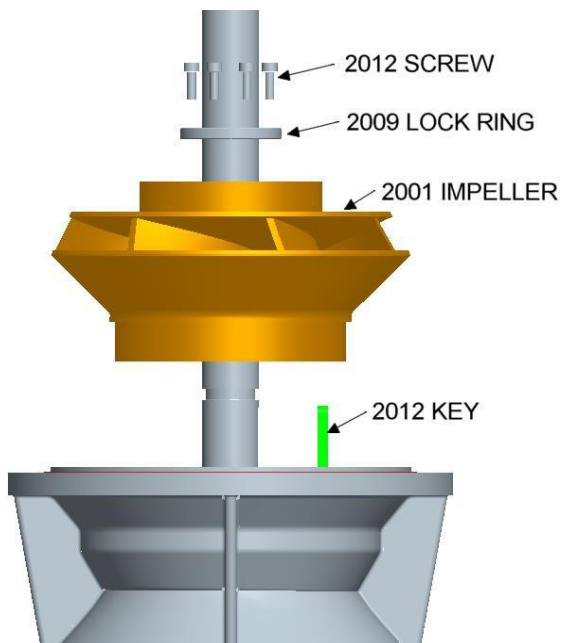

4. Loosen the set screw (2017) and remove the bowl (2002)

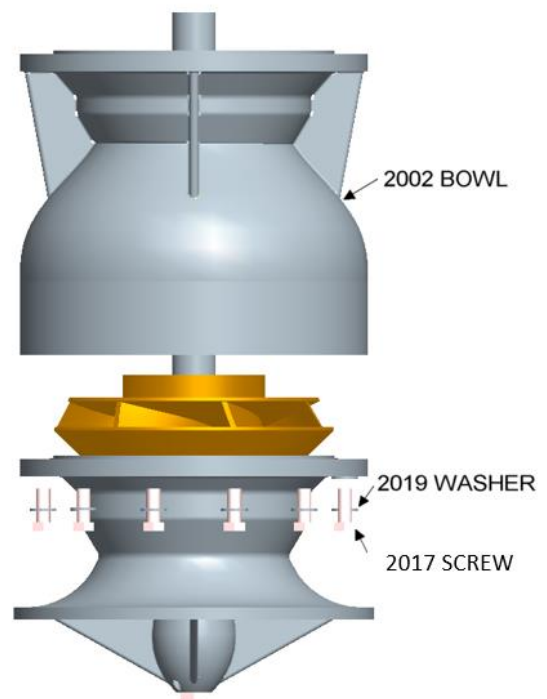

5. Remove the bell (2003)

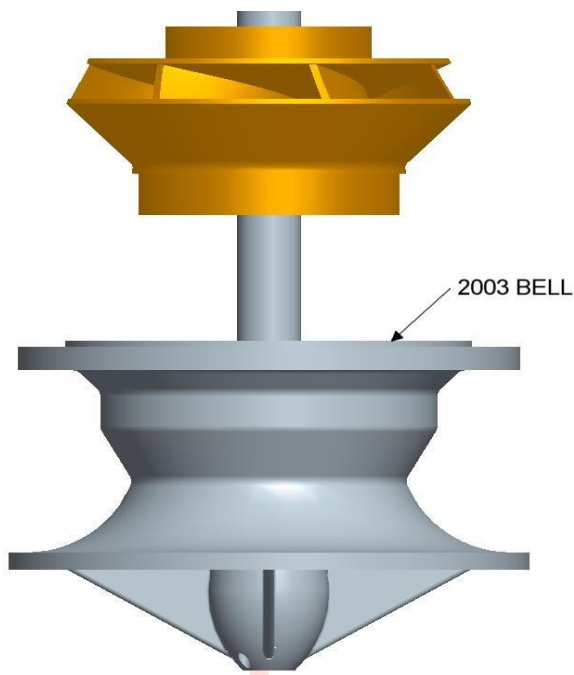

6. Loosen the allen screw (2012) and remove the lock ring (2009) and impeller (2001)

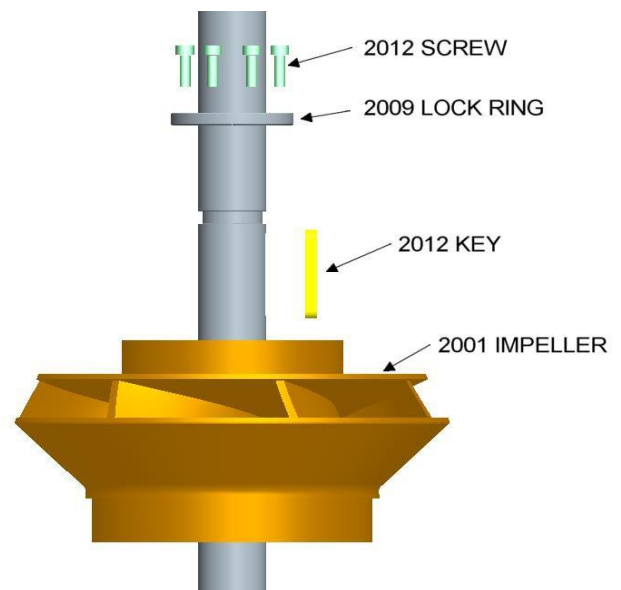

Take DL350-2N for example (DL350/350B/500 have the same way to dismantle bowl unit):

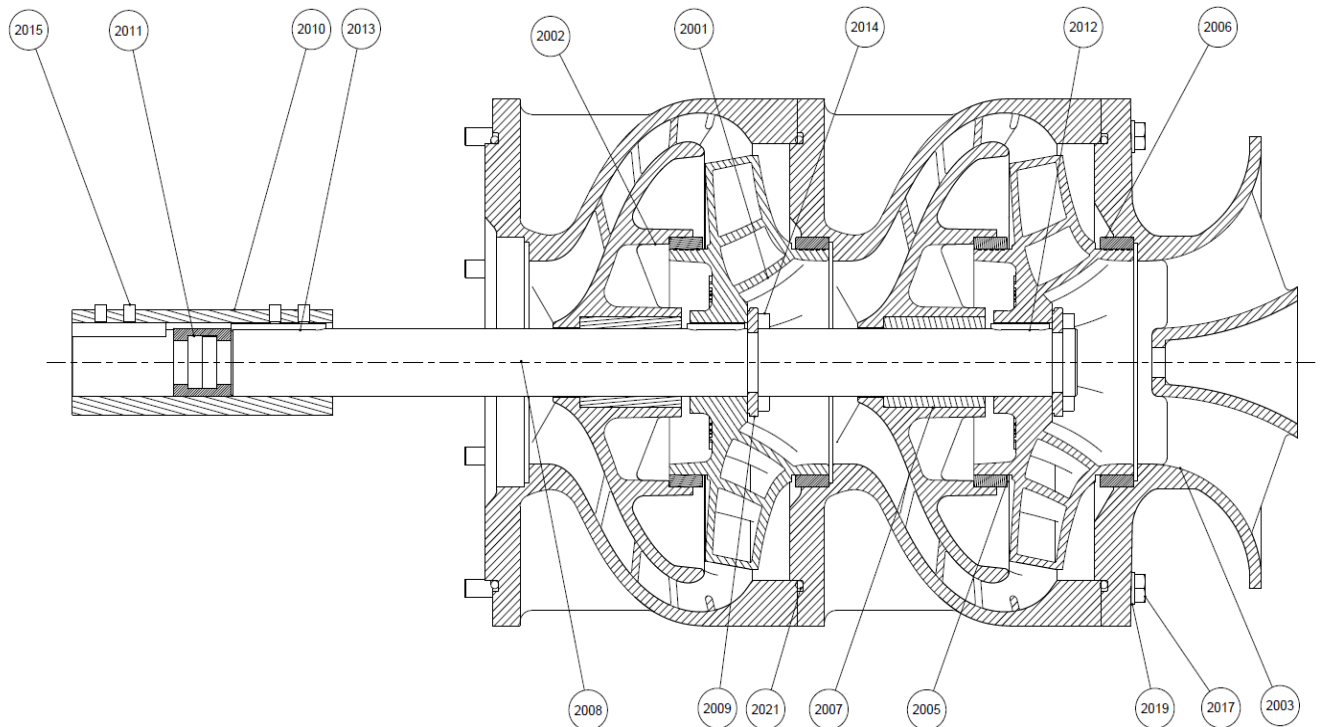

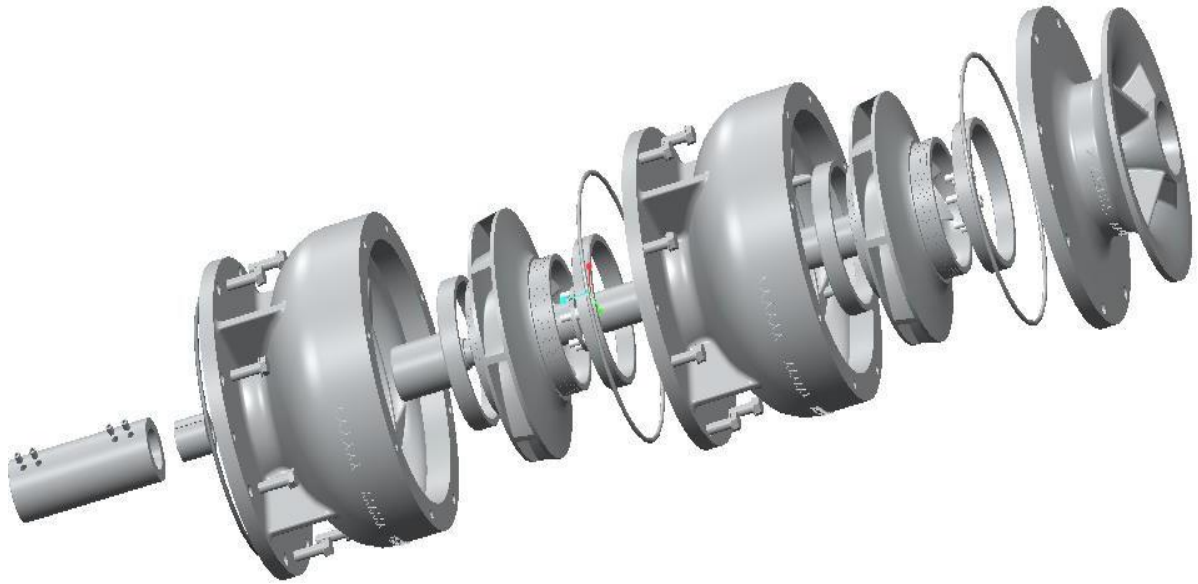

No.	Description	Quantity	No.	Description	Quantity
2021	O-ring $\varnothing 288 \times 5.3$	3	2009	Lock ring	2
2019	Washer M12	24	2008	Bowl shaft, 2 stages	1
2017	Set Screw M12x40	24	2007	Bearing $\varnothing 45 \times 70$	2
2015	Point screw M8X12 Din916	4	2006	Wear ring $\varnothing 166 \times \varnothing 150 \times 22$	2
2014	Allen Screw M8X20	12	2005	Back wear ring $\varnothing 166 \times \varnothing 150 \times 22$	2
2013	Key 14x9x65	1	2003	Bell	1
2012	Key 14x9x40	2	2002	Bowl	1
2011	HALF CONNECTOR	1	2001	Impeller	2
2010	Half coupling	1			

1. Loosen the set screw (2017) and washer (2019), then remove the bell



2. Loosen the Allen screw (2014) and remove the lock ring (2009) and impeller (2001)



3. Loosen the set screw (2017) and washer (2019), then remove the bowl

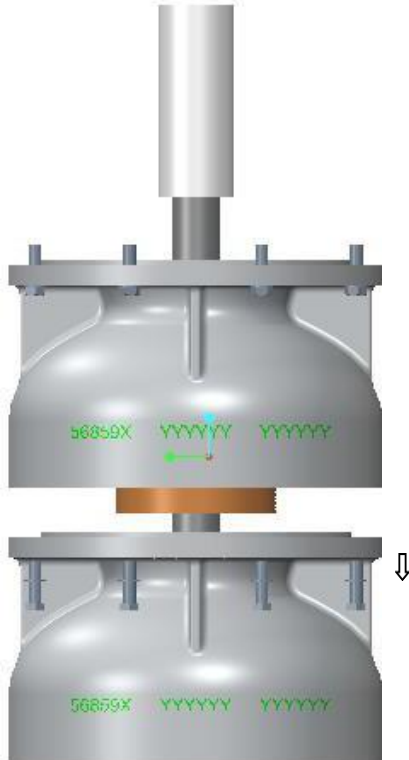

4. Loosen the Allen screw (2014) and remove the lock ring (2009) and second impeller (2001)



10.3 ASSEMBLY

Assembly sequence is in reverse order to dismantling.

Note:

1. Tighten the bolts in accordance with the Torque indicated in table below.

Tightening Torque Table

Bolt	Tightening Torque (Nm)
M5	4.7
M6	8.0
M8	19.5
M10	38.6
M12	67.4
M16	167
M20	336
M24	582

2. Bushing (Pos.9) to be glued with Loctite 243 or similar on the outer surface pressed inside the Packing Box (Pos.24) bore. Ensure that no glue enters between shaft and bushing.

3. Screws (Pos.26) to be glued with Loctite 243.

11. TROUBLE SHOOTING

PROBLEMS	CAUSES	REMEDIES
No or too low capacity	<ol style="list-style-type: none"> 1. Wrong direction of rotation; 2. Piping system choked ; 3. Impeller or diffuser choked ; 4. Liquid contains too much air ; 5. Wear ring or bearing is seriously worn; 6. Too low speed; 7. impeller or key damaged; 8. Low liquid level 	<ol style="list-style-type: none"> 1. Re-connect motor wires for correct direction of rotation 2. Clean or replace pipeline 3. Clean the pump 4. Check min. liquid level (see dimensional drawing) 5. Replace wear ring or bearing 6. Electric motor running on two phases or lower frequency 7. Replace impeller or key 8. Raise submersible liquid level
Overload or over-current	<ol style="list-style-type: none"> 1. The liquid density is heavy 2. Foreign body in pump; 3. Electric motor is running on two phases; 4. Too high speed; 5. Pump out of alignment 6. Improper shaft adjustment 7. Worn bearing 	<ol style="list-style-type: none"> 1. Contact DESMI 2. Dismantle the pump, remove the foreign body 3. Check fuses, cable connection, and cable 4. Decrease frequency 5. Re-align coupling 6. Re-adjust shaft 7. replace bearing
Capacity is unstable	<ol style="list-style-type: none"> 1. Liquid contains too much air ; 2. Foreign body in pump suction end; 3. Insufficient liquid level; 4. Coupling or key broken; 	<ol style="list-style-type: none"> 1. Ensure min. liquid level 2. Dismantle the pump, remove the foreign body 3. Increase liquid level 4. Replace parts
Abnormal vibration	<ol style="list-style-type: none"> 1. Liquid contains too much air ; 2. Improper alignment; 3. Foreign object in impeller result in imbalance; 4. Shaft bent; 5. Guide bearing worn seriously; 	<ol style="list-style-type: none"> 1. Ensure min. liquid level 2. Re-align coupling 3. Dismantle pump and clean impeller 4. Dismantle pump and repair shaft 5. Replace bearing
Abnormal noise	<ol style="list-style-type: none"> 1. Cavitations in pump; 2. Incorrect alignment; 3. Defective bearings; 4. Parts loose; 	<ol style="list-style-type: none"> 1. Liquid contains too much air/ liquid temperature too high 2. Align the pump and motor 3. Replace bearings 4. Reset or replace parts
Too much leakage	<ol style="list-style-type: none"> 1. Seal spring pressure is not enough; 2. Worn oil seal; 	<ol style="list-style-type: none"> 1. Adjust seal spring compression ratio 2. Replace new oil seal

12. REPLACEMENT OF WEAR PARTS

12.1 WEAR RING REPLACEMENT

The wear ring shall be replaced when the flow decreases significantly or when the clearance between wear ring and impeller exceeds the value listed in the following table.

Pump type	Nominal clearance (mm)	Maximum clearance (mm)
DL300/DL300B	0.50	1.00
DL400/DL400B	0.50	1.00
DL350/DL350B	0.50	1.00
DL500	0.50	1.00

12.2 REPLACEMENT OF GUIDE BEARING AND SLEEVE

When the clearance between the guide bearing and shaft exceeds the value listed in the following table the most worn parts shall be replaced.

Pump type	Nominal clearance of guide bearing (mm)	Maximum clearance (mm)
DL300/DL300B	0.3	0.5
DL400/DL400B	0.3	0.5
DL350/DL350B	0.3	0.5
DL500	0.3	0.5

12.3 REPLACEMENT OF SEALING RINGS

It is recommended that all sealing rubber rings shall be replaced during pump overhaul.

13. EU DECLARATION OF CONFORMITY

DESMI PUMPING TECHNOLOGY A/S, hereby declare that our pumps of the type DESLUBE are manufactured in conformity with the following essential safety and health requirements in the COUNCIL DIRECTIVE 2006/42/EC on machines, Annex 1.

The following harmonized standards have been used:

EN/ISO 13857:2019	Safety of machinery. Safety distances to prevent danger zones being reached by the upper limbs
EN 809:1998 + A1:2009	Pumps and pump units for liquids – Common safety requirements
EN12162:2001+A1:2009	Liquid pumps – Safety requirements – Procedure for hydrostatic testing
EN 60204-1:2018	Safety of machinery – Electrical equipment of machines (item 4, General requirements)

Pumps delivered by us connected with prime movers are CE-marked and comply with the above requirements.

Pumps delivered by us without prime movers (as partly completed machinery) must only be used when the prime mover and the connection between prime mover and pump comply with the above requirements.

Nørresundby, September 20 2024



Henrik Mørkholt Sørensen
Managing Director

DESMI Pumping Technology A/S
Tagholm 1
9400 Nørresundby

14. INFORMATION RELEVANT FOR DISASSEMBLY, RECYCLING OR DISPOSAL AT END-OF- LIFE

No dangerous materials are used in DESMI pumps – please refer to DESMI Green Passport (can be sent on request – contact a DESMI sales office) – i.e. common recycling companies can handle the disposal at end-of-life. Alternatively the pump and motor can be returned to DESMI at end-of-life for safe recycling.