

INSTALLATION, OPERATION AND MAINTENANCE INSTRUCTIONS

## DESMI Vertical Turbine Pumps Type DESLUBE

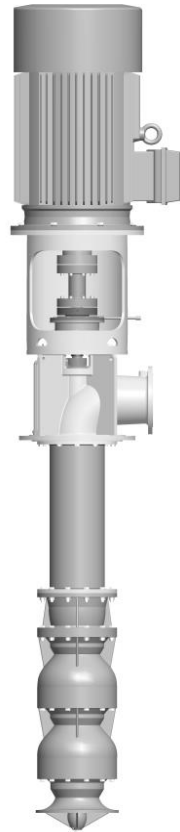

**DESMI Pumping Technology A/S**  
Tagholm 1 – DK-9400 Nørresundby – Denmark

Tel.: +45 96 32 81 11  
Fax: +45 98 17 54 99  
E-mail: [desmi@desmi.com](mailto:desmi@desmi.com)  
Internet: [www.desmi.com](http://www.desmi.com)

Manual: T1498	Language: English	Revision: K (09/24)
------------------	----------------------	------------------------

Special pump No.. .....



## Table of Contents:

<b>1. PRODUCT DESCRIPTION .....</b>	<b>1</b>
<b>2. TECHNICAL DATA .....</b>	<b>1</b>
2.1 EXPLANATION OF THE TYPE NUMBER .....	1
2.2 TECHNICAL DESCRIPTION .....	2
<b>3. TRANSPORT/STORAGE/DELIVERY .....</b>	<b>2</b>
3.1 TRANSPORT/STORAGE .....	2
3.2 DELIVERY .....	2
<b>4. INSTALLATION .....</b>	<b>3</b>
4.1 MOUNTING/FASTENING .....	3
4.2 WIRING .....	3
4.3 ASSEMBLY DIMENSIONAL DRAWING .....	3
<b>5. INSPECTING THE PUMP .....</b>	<b>7</b>
5.1 INSPECTION .....	7
5.2 SHAFT ADJUSTMENT .....	7
<b>6. DISMANTLING SAFETY .....</b>	<b>7</b>
<b>7. SYSTEM BALANCING .....</b>	<b>7</b>
<b>8. PREPARATION FOR STARTING .....</b>	<b>8</b>
<b>9. STARTING AND MAINTANENCE .....</b>	<b>8</b>
<b>10. STOPPING .....</b>	<b>9</b>
<b>11. ASSEMBLY AND DISASSEMBLY SEQUENCE .....</b>	<b>9</b>
11.1 BOWL ASSEMBLY - SEE ASSEMBLY DRAWING .....	9
11.2 TOP PART ASSEMBLY - SEE ASSEMBLY DRAWING .....	9
11.3 FITTING SHAFT SEAL .....	10
11.4 DISASSEMBLY .....	10
<b>13. REPLACEMENT OF WEAR PARTS .....</b>	<b>12</b>
13.1 WEAR RING REPLACEMENT .....	12
13.2 REPLACEMENT OF GUIDE BEARING AND SLEAVE .....	12
13.3 REPLACEMENT OF SEALING RINGS .....	12
<b>14. EU DECLARATION OF CONFORMITY .....</b>	<b>13</b>
<b>15. INFORMATION RELEVANT FOR DISASSEMBLY, RECYCLING OR DISPOSAL AT END-OF-LIFE .....</b>	<b>14</b>
<b>16. ASSEMBLY DRAWINGS AND PARTS LISTS (DL400-2 FOR EXAMPLE) .....</b>	<b>14</b>
16.1 SUB-ASSEMBLY: BOWL ASSEMBLY .....	14
16.2 SUB-ASSEMBLY: HEAD AND COLUMN ASSEMBLY .....	15
16.3 SUB-ASSEMBLY: MECHANICAL SEALING UNIT .....	17
16.4 SUB-ASSEMBLY: BEARING ASSEMBLY UNIT .....	18

## 1. PRODUCT DESCRIPTION

These operation and maintenance instructions apply to the DESMI Deslube-pump series.

DESMI Deslube is a multi-stage centrifugal pump with thrust bearing unit. The pump is further equipped with a closed impeller.

The pump is designed for pumping liquid like water and lubricating oils with temperatures between 0 and 80°C.

## 2. TECHNICAL DATA

The pumps are manufactured in various material combinations which appear from the type number on the name plate. See below.

### 2.1 EXPLANATION OF THE TYPE NUMBER

All the Deslube-pumps are provided with a name plate. The type number indicated on the name plate is built up as follows:

DL XXX-N /MR

XXX : Bowl outside diameter

N : Number of stages

M : The material combination of the pump.

R : The assembly combination of the pump.

M may be the following:

A : Standard. Casing: GG20. Impeller/wear ring: RG5.

Standard

B : Standard. Casing: GG20. Impeller/wear ring: Stainless steel.

C : All cast iron.

D : Casing: RG5. Impeller/wear ring: RG5.

E : Special bronze casing and/or impeller

The pumps are available in other material combinations at request.

R may be the following:

09: With bare shaft end.

12: Flange-mounted with electric motor.

Standard

No code M hint A, No code R hint 12

Before putting a pump into operation, the suitability of the material combination of the pump must always be taken into consideration. In case of doubt, contact the supplier.

If the pumps are designed for special purposes the following is to be indicated:

Pump No. :

Pump type :

Application :

Comment :

Other requirements:

## 2.2 TECHNICAL DESCRIPTION

The noise level from the pump depends on the motor type supplied, as the noise from the pump can be calculated as the noise level of the motor + 2dB (A). The noise level of the motor appears from the instruction manual for the motor. The pump performance data appears on the nameplate of the pump.

## 3. TRANSPORT/STORAGE/DELIVERY

### 3.1 TRANSPORT/STORAGE

Lift the pump by placing the rope around it and see to it that the pump is balanced.

The rope must not bear against sharp edges and corners.

Lifting eyes might be mounted in the pump and used instead.

Before shipment the pump is to be fastened securely on a pallet or the like.

Storage area must be reasonably level, stable ground not subject to flooding.

Units must be supported on blocks at intervals along their length to keep the weight off the flanges and suction bell.

Small pumps shipped on skids may be stored as received, provided the skids have not been damaged in transit

All machined surfaces and exposed shafting must be coated with rust preventative adequate to protect these areas for the length of storage

The weights of the cast iron pumps without motor are stated in the following table:

Pump	Weight (kg)	Pump	Weight (kg)	Pump	Weight (kg)
Deslube400-1stages	565	Deslube300-1stages	361	Deslube400B-1stages	621
Deslube400-2stages	670	Deslube300-2stages	399	Deslube400B-2stages	724
Deslube400-3stages	718	Deslube300-3stages	415	Deslube400B-3stages	766
Deslube400-4stages	823	Deslube300-4stages	453	Deslube400B-4stages	863
Deslube400-5stages	928	Deslube300-5stages	491	Deslube400B-5stages	957
Deslube400-6stages	1033	Deslube300-6stages	529	Deslube400B-6stages	1050

(Length from base plate to bell tip listed above is about 2m)

### 3.2 DELIVERY

- Check on receipt that the consignment is complete and undamaged.
- Defects and damages, if any, are to be reported to the carrier and the supplier immediately in order that a claim can be advanced.

## 4. INSTALLATION

### 4.1 MOUNTING/FASTENING

The pump should be mounted on a sturdy base plate with a flat and horizontal surface to avoid distortion.

- Avoid distortion of the base plate.
- Avoid distortion of the piping system.
- Check carefully that pump and motor are accurately aligned.
- Shaft can easily rotate without any noise.



At installations pumping hot or very cold liquids, the operator must be aware that it is dangerous to touch the pump surface and, consequently, he must take the necessary safety measures.

### 4.2 WIRING



Wiring to be carried out by authorised skilled workmen according to the rules and regulations in force.

### 4.3 ASSEMBLY DIMENSIONAL DRAWING

Assembly dimensional drawing will be sent to the customer for each pump type. The following drawings are just examples. Please find the actual drawing in supplier's document package.

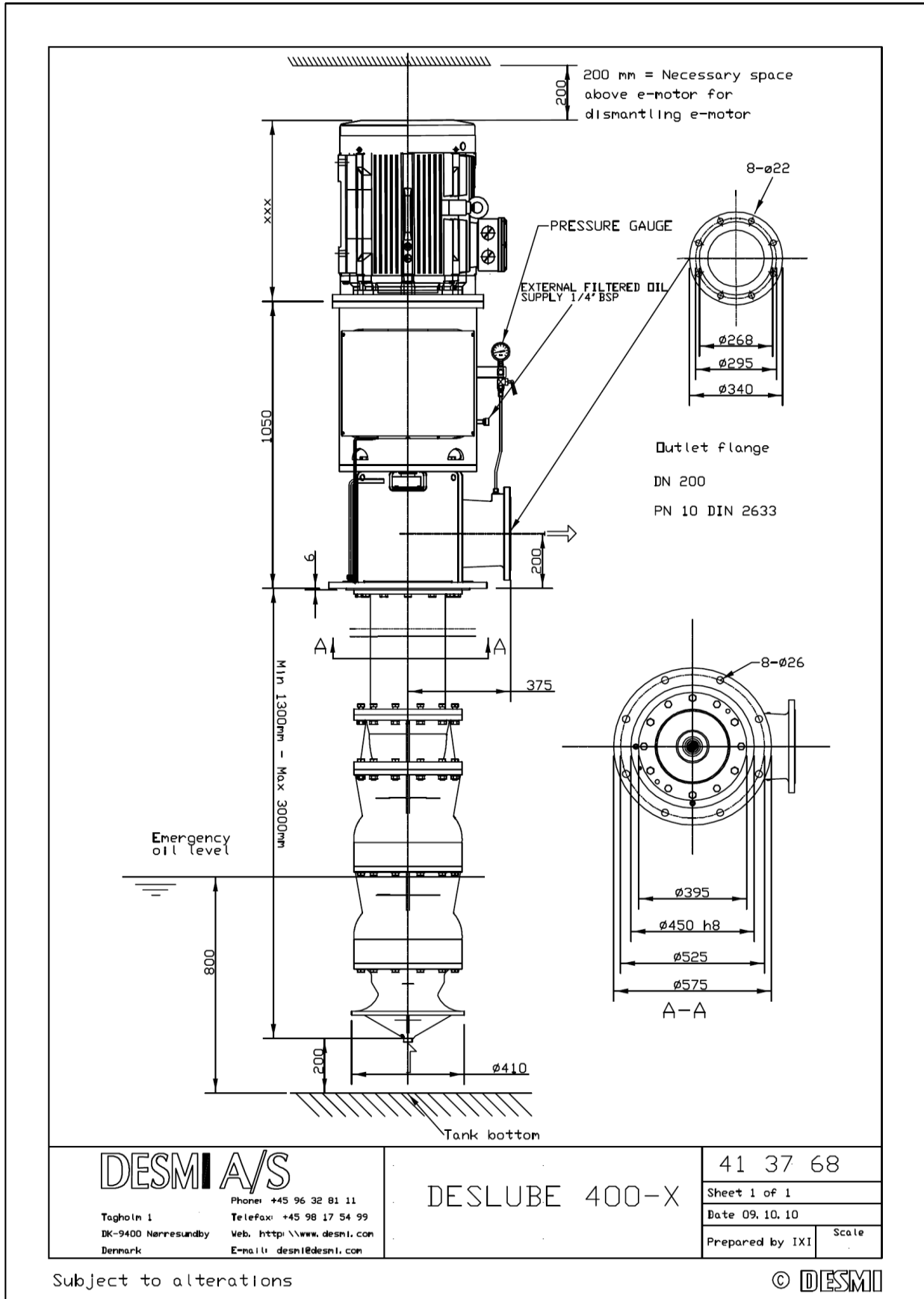

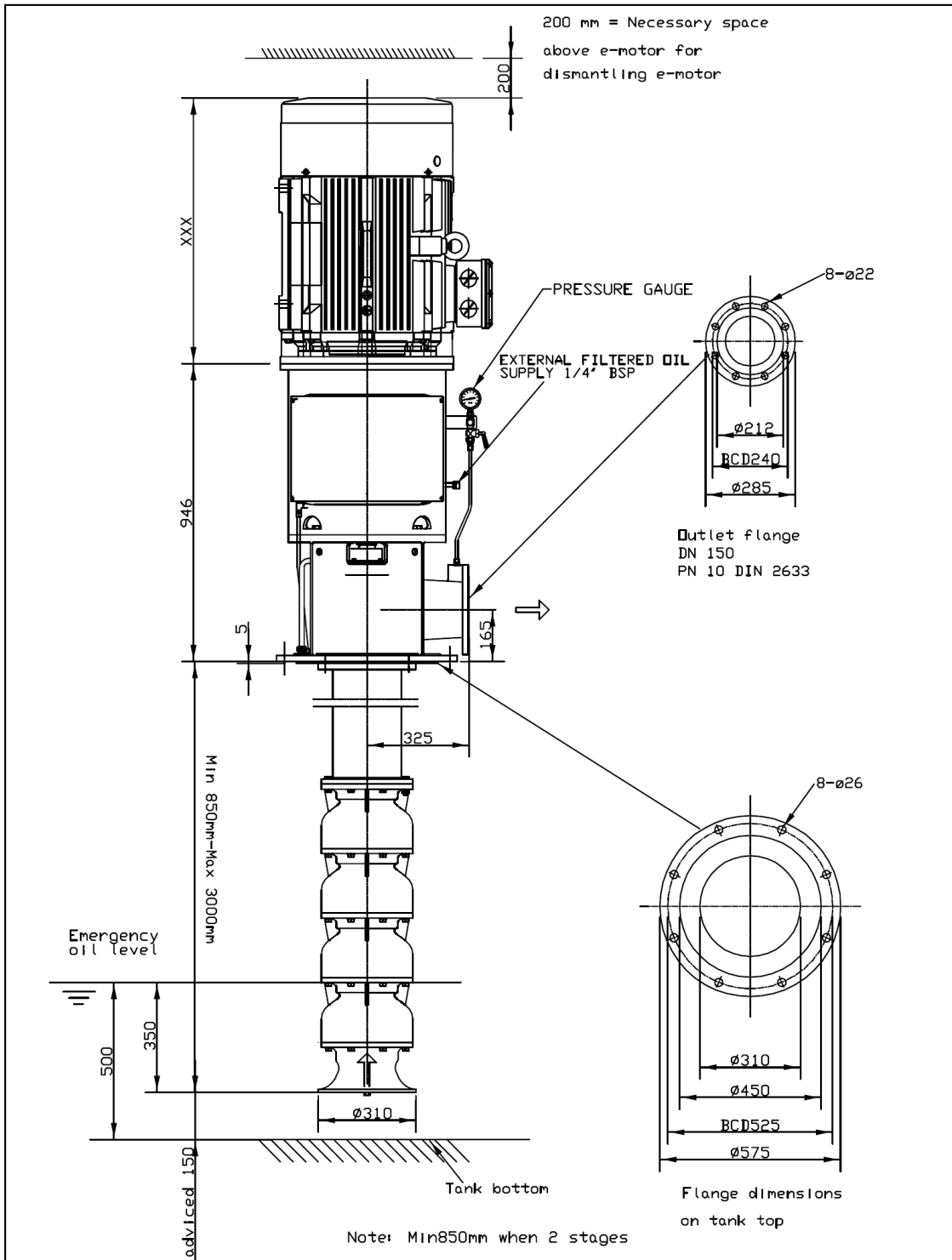

**DESMI A/S**

Tagholm 1  
DK-9400 Nørresundby  
Denmark

Phoner: +45 96 32 81 11  
Telefax: +45 98 17 54 99  
Web: <http://www.desmi.com>  
E-mail: [desmi@desmi.com](mailto:desmi@desmi.com)

DESLUBE 300-X

41 37 67

Sheet 1 of 1

Date 09.10.10

Prepared by IXI

Scale

Subject to alterations

© DESMI

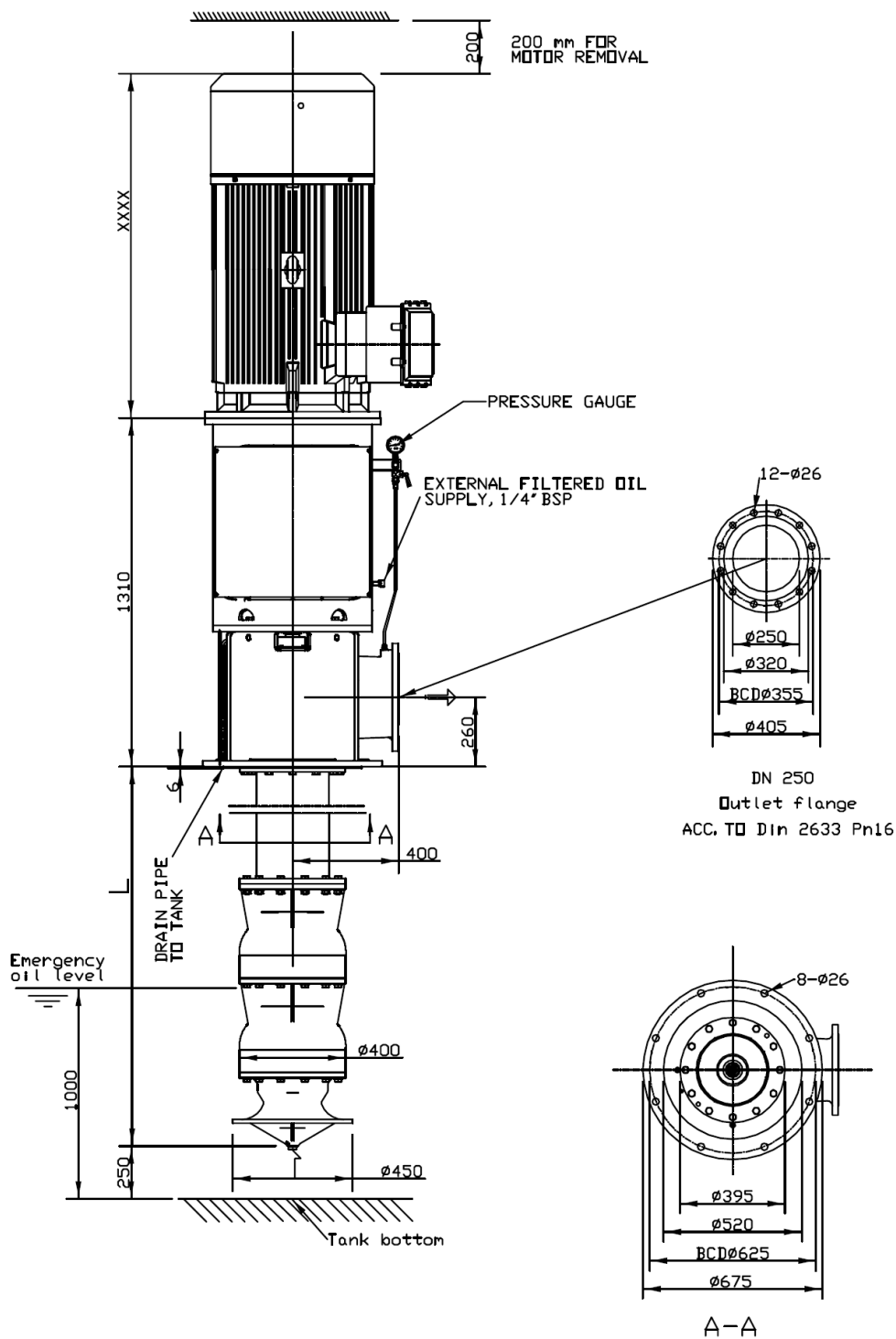

**DESMI A/S**

Tagholm 1  
DK-9400 Nørresundby  
Denmark

Phone: +45 96 32 81 11  
Telefax: +45 98 17 54 99  
Web: <http://www.desmi.com>  
E-mail: [desmi@desmi.com](mailto:desmi@desmi.com)

DESLUBE 400B-X

41 40 75

Sheet 1 of 1  
Date 2009.11.03  
Prepared by IXI

Scale

Subject to alterations

© DESMI



## 5. INSPECTING THE PUMP

Before any inspection of the pump, check that the unit cannot be started unintentionally.



- The system is to be without pressure and drained of liquid.
- The repairman must be familiar with the type of liquid, which has been pumped as well as with the safety measures he has to take when handling the liquid.
- Inspect the shaft seal for leaks at regular intervals.

### 5.1 INSPECTION

When the pump has been dismantled, check the following parts for wear and damage:

- Shaft seal/sealing seat : Check seat for flatness and cracks.  
Check rubber parts for elasticity.
- Bearings : Replace in case of wear and noise.

### 5.2 SHAFT ADJUSTMENT

When the pump has been assembled, check that the shaft rotates freely; if necessary adjust the axial clearance by turning the lock nut on the up-shaft. The axial raise is **2~3mm**. Don't raise shaft too much so that pump shaft can't rotate freely.

## 6. DISMANTLING SAFTY



Before dismantling the pump make sure that it has stopped. Empty the pump of liquid before it is dismantled from the piping system. If the pump has been pumping dangerous liquids you are to be aware of this and take the necessary safety precautions.

If the pump has been pumping hot liquids, take great care that it is drained before it is removed from the piping system.

## 7. SYSTEM BALANCING

It is often difficult to calculate a delivery head in advance. It is, however, decisively important to the capacity of liquid delivered.

A considerably smaller delivery head than expected will increase the capacity of liquid delivered, causing increased power consumption.

Therefore, after start-up, it is necessary to check either the capacity of liquid delivered or the power consumption of the pump e.g. by measuring the current intensity of the connected motor. Together with a reading of the differential pressure the capacity of water delivered can be determined against the characteristics of the pump.

Should the pump not function as intended, please proceed according to the fault-finding list. Bear in mind, though, that the pump was carefully checked and tested at the factory and that the majority of faults stem from the piping system.

## 8. PREPARATION FOR STARTING

- 8.1 Check motor rotating direction with the pins by starting up for a short while. It is recommended that the electrical connection and rotating direction check be carried out prior to connecting with pump.
- 8.2 **Before start up: Fill the bearing housing with clean oil up to the sight glass before starting the pump.**

**The pump bearings must be lubricated by an externally clean oil from lubricating pipe line or oil bottle. Before starting the pump, ensure that the lubricating oil is fed into the bearing unit. If bearing is lubricated by pipe line, the oil flow shall be about 0.1-2 litres/minute through the bearing unit. The oil flow can be measured by loosening the oil drain pipe on the pump - collect the oil in a bucket. The bearing unit shall be filled with oil up to the sight glass and external oil shall be supplied. The oil entering the bearing unit must be clean.**

- 8.3 The rotor shall rotate freely by turning it at the coupling without any noise
- 8.4 Check if the liquid level in tank or well meets the submersible depth requirement for the pump.
- 8.5 Check if motor control and protection system are reliable.

**The pump is not warranted for pumping foreign material in the liquid.**

## 9. STARTING AND MAINTANENCE

- 9.1 Set the discharge valve at nearly closed position.
- 9.2 **Check supply of lubricating oil to bearing unit. Measure oil flow to 0.1-2 l/min.**
- 9.3 Ensure liquid level is higher than min. liquid level requirement.
- 9.4 Start the pump; open the discharge valve slowly to avoid overheating/pressure.
- 9.5 The pump shall be stopped and checked as soon as one of the following phenomena occurs:
1. Current exceeds the specified value or fluctuates widely;
  2. Obvious vibrations and noise.
  3. Bearing temperature or motor winding temperature exceeds the value specified in the documents provided with the equipment.
- 9.6 The operator shall pay attention to the follows during normal operation:
1. Check and record the operating conditions, such as current, voltage, discharge pressure and capacity daily.
  2. Check for leakage daily. Check the compression ratio of mechanical seal spring in case leakage occurs.

## 10. STOPPING

- 10.1 Shut-off the power supply for motor.
- 10.2 Close discharge valve.
- 10.3 Close external cooling oil if necessary.

## 11. ASSEMBLY AND DISASSEMBLY SEQUENCE

### 11.1 BOWL ASSEMBLY - see assembly drawing

1. Mount bearing item 2007, into bell item 2003
2. Mount O-ring item 2021 and front wear ring item 2006 into bell item 2003
3. Mount down-shaft item 2012 into the bell
4. Mount impeller item 2001 on shaft item 2008 with lock ring 2009, then tighten the lock ring with Allen screw 2014
5. Mount back wear ring item 2005 in bowl item 2002, and then mount the bowl on the down- shaft.
6. Mount O-ring item 2021 and front wear ring item 2006 into the bowl
7. For multi-stage pumps repeat the steps 4, 5 and 6. Then tighten all screws.  
Down-part is finished. Later for top part

### 11.2 TOP PART ASSEMBLY - see assembly drawing

1. Mount bearing item 9 into the packing box item 3. Put the o-ring item 21 into the groove of packing box item 3, then mount packing box into head item 1.
2. Mount top-shaft item 8 into packing box item 3.
3. Mechanical sealing unit assembly: mount mechanical sealing into the sealing seat. Now Mount the sealing adjust tube, place O-ring into adjust tube. Tighten the sleeve locker and the mechanical sealing unit is OK.
4. Put the seal paper item 23 onto the mechanical sealing unit flange surface, then mount the mechanical sealing unit onto the packing box item 3 along the top-shaft slowly, and tighten up.
5. Mount the bearing assembly unit item 12 onto the head item 1, and tighten up.  
Rotate the four stubs/robs on oil tube unit, to guarantee that the oil tube should be tighten enough to lower surface of bearing unit and top surface of mechanical sealing unit.  
(If the bearing unit has been disassembled start by mounting the bearing box cover and rubber shaft seal into the pump coupling. Pay attention to the rubber shaft sealing direction, and then mount the ball bearing and conical bearing on the coupling. Finally mount the coupling with bearings into the bearing box, tighten the screw for bearing box cover).
6. Mount the lock washer item 24 and lock nut item 11. Tighten the nut to contact with the washers and coupling surface. Mark this position and tighten the lock nut another two revolutions to ensure a 2-3 mm gap between the impellers and sealing ring (that means the shaft will be lifted 2-3mm, before lifting the shaft, pay attention to that the shaft is push to the down limit).
7. Mount the spacer coupling
8. Mount the motor coupling on the motor shaft (if removed).
9. Mount the motor and motor coupling with spacer coupling, tighten the motor.
10. Adjust the coupling gap (motor coupling and spacer coupling, spacer coupling and pump coupling) to be 2mm, then tighten the point screw on coupling to fix the axial position.

Note: Tighten the bolts in accordance with the torque indicated in the table below.

Tightening Torque Table

Bolt	Tightening Torque (Nm)
M5	4.7
M6	8.0
M8	19.5
M10	38.6
M12	67.4
M16	167
M20	336
M24	582

### 11.3 FITTING SHAFT SEAL

Before fitting the shaft seal, clean the recess in the mechanical sealing seat. When fitting the seat, remove the protective coating (if any) without scratching the lapped surface. Dip the outer rubber ring of the seat into soapy water. Now press the seat into place with the fingers and check that all parts are correctly imbedded.

If it is necessary to use tools for assembling, protect the sliding surface of the seat to prevent it from being scratched or cut. Lubricate the inner surface of the slide ring rubber bellows with soapy water and push it over the shaft.

Push the slide ring over the shaft with the hand. If the rubber bellows is tight, use a fitting tool and take care that the slide ring is not damaged. If the carbon ring is not fixed, it is important to check that it is fitted correctly, i.e. the chamfered/lapped side is to face the seat.

When using soapy water on the shaft, the bellows will settle and seat in about 15 minutes and until then tightness should not be expected. After start, please check that there are no leaks.

### 11.4 DISASSEMBLY

Disassembly sequence is in reverse order to assembly.

## 12. TROUBLE SHOOTING

PROBLEMS	CAUSES	REMEDIES
No or too low capacity	<ol style="list-style-type: none"> <li>1. Wrong direction of rotation;</li> <li>2. Piping system choked ;</li> <li>3. Impeller or diffuser choked ;</li> <li>4. Liquid contains too much air ;</li> <li>5. Wear ring or bearing is seriously worn;</li> <li>6. Too low speed;</li> <li>7. impeller or key damaged;</li> <li>8. Low liquid level</li> </ol>	<ol style="list-style-type: none"> <li>1. Re-connect motor wires for correct direction of rotation.</li> <li>2. Clean or replace pipeline</li> <li>3. Clean the pump</li> <li>4. Check min. liquid level (see dimensional drawing).</li> <li>5. Replace wear ring or bearing</li> <li>6. Electric motor running on two phases or lower frequency.</li> <li>7. Replace impeller or key</li> <li>8. Raise submersible liquid level</li> </ol>
Overload or over-current	<ol style="list-style-type: none"> <li>1. The liquid density is heavy</li> <li>2. Foreign body in pump;</li> <li>3. Electric motor is running on two phases;</li> <li>4. Too high speed;</li> <li>5. Pump out of alignment</li> <li>6. Improper shaft adjustment</li> <li>7. Wron bearing</li> </ol>	<ol style="list-style-type: none"> <li>1. Contact DESMI</li> <li>2. Dismantle the pump, remove the foreign body.</li> <li>3. Check fuses, cable connection, and cable</li> <li>4. Decrease frequency</li> <li>5. Re-align coupling</li> <li>6. Re-adjust shaft</li> <li>7. replace bearing</li> </ol>
Capacity is unstable	<ol style="list-style-type: none"> <li>1. Liquid contains too much air ;</li> <li>2. Foreign body in pump suction end;</li> <li>3. Insufficient liquid level;</li> <li>4. Coupling or key broken;</li> </ol>	<ol style="list-style-type: none"> <li>1. Ensure min. liquid level</li> <li>2. Dismantle the pump, remove the foreign body.</li> <li>3. Increase liquid level.</li> <li>4. Replace parts.</li> </ol>
Abnormal vibration	<ol style="list-style-type: none"> <li>1. Liquid contains too much air ;</li> <li>2. Improper alignment;</li> <li>3. Foreign object in impeller result in imbalance;</li> <li>4. Shaft bent;</li> <li>5. Guide bearing worn seriously;</li> </ol>	<ol style="list-style-type: none"> <li>1. Ensure min. liquid level</li> <li>2. Re-align coupling</li> <li>3. Dismantle pump and clean impeller</li> <li>4. Dismantle pump and repair shaft</li> <li>5. Replace bearing</li> </ol>
Abnormal noise	<ol style="list-style-type: none"> <li>1. Cavitations in pump;</li> <li>2. Incorrect alignment;</li> <li>3. Defective bearings;</li> <li>4. Parts loose;</li> </ol>	<ol style="list-style-type: none"> <li>1. Liquid contains too much air/ liquid temperature too high.</li> <li>2. Align the pump and motor</li> <li>3. Replace bearings</li> <li>4. Reset or replace parts</li> </ol>
Too much leakage	<ol style="list-style-type: none"> <li>1. Mechanical seal worn;</li> <li>2. Seal spring pressure is not enough;</li> </ol>	<ol style="list-style-type: none"> <li>1. Replace mechanical seal</li> <li>2. Adjust seal spring compression ratio</li> </ol>

## 13. REPLACEMENT OF WEAR PARTS

### 13.1 WEAR RING REPLACEMENT

The wear ring shall be replaced when the flow decreases significantly or when the clearance between wear ring and impeller exceeds the value listed in the following table.

Pump type	Nominal clearance (mm)	Maximum clearance (mm)
DL300	0.50	1.00
DL400/DL400B	0.50	1.00

### 13.2 REPLACEMENT OF GUIDE BEARING AND SLEAVE

When the clearance between the guide bearing and shaft exceeds the value listed in the follow table the most worn parts shall be replaced.

Pump type	Nominal clearance of guide bearing (mm)	Maximum clearance (mm)
DL300	0.3	0.5
DL400/DL400B	0.3	0.5

### 13.3 REPLACEMENT OF SEALING RINGS

It is recommended that all sealing rubber rings shall be replaced during pump overhaul.

## 14. EU DECLARATION OF CONFORMITY

DESMI Pumping Technology A/S, hereby declare that our pumps of the type DESLUBE are manufactured in conformity with the following essential safety and health requirements in the COUNCIL DIRECTIVE 2006/42/EC on machines, Annex 1.

The following harmonized standards have been used:

EN/ISO 13857:2019	Safety of machinery. Safety distances to prevent danger zones being reached by the upper limbs
EN 809:1998 + A1:2009	Pumps and pump units for liquids – Common safety requirements
EN12162:2001+A1:2009	Liquid pumps – Safety requirements – Procedure for hydrostatic testing
EN 60204-1:2018	Safety of machinery – Electrical equipment of machines (item 4, General requirements)

Pumps delivered by us connected with prime movers are CE-marked and comply with the above requirements.

Pumps delivered by us without prime movers (as partly completed machinery) must only be used when the prime mover and the connection between prime mover and pump comply with the above requirements.

Nørresundby, September 20 2024



Henrik Mørkholt Sørensen  
Managing Director

DESMI Pumping Technology A/S  
Tagholm 1  
9400 Nørresundby

## 15. INFORMATION RELEVANT FOR DISASSEMBLY, RECYCLING OR DISPOSAL AT END-OF-LIFE

No dangerous materials are used in DESMI pumps – please refer to DESMI Green Passport (can be sent on request – contact a DESMI sales office) – i.e. common recycling companies can handle the disposal at end-of-life. Alternatively the pump and motor can be returned to DESMI at end-of-life for safe recycling.

## 16. ASSEMBLY DRAWINGS AND PARTS LISTS (DL400-2 for Example)

### 16.1 SUB-ASSEMBLY: BOWL ASSEMBLY

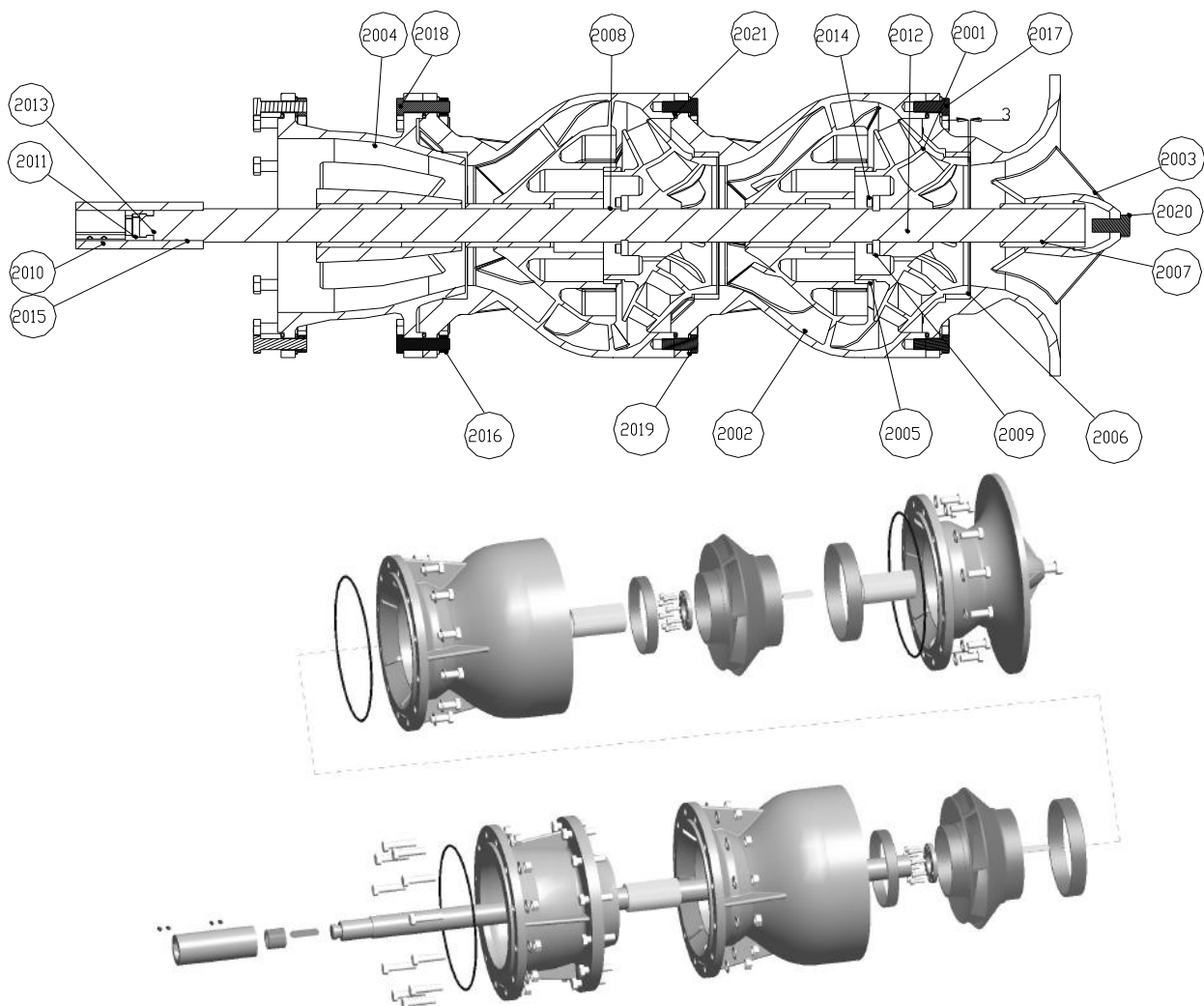

No.	Description	Quantity	No.	Description	Quantity
2021	O-ring 320x5.3 GB/T3452.1	4	2010	Shaft coupling Ø45	1
2020	M20X40 A4 Din 933	1	2009	Lock ring Ø50	2
2019	Washer M16 Din127	48	2008	Pump shaft, 2 stages	1
2018	M16X65 Din 933	24	2007	Bearing Ø50X120	4
2017	Bolt M16X40	24	2006	Wear ring 205	2
2016	Nut M16	24	2005	Back wear ring 162	2



2015	Point screw M8X12 Din916	4	2004	Discharge Case 400/10"	1
2014	Bolt M8X25 Din912	16	2003	400 Bell	1
2013	Key 14X9X65	1	2002	400 Bowl	2
2012	Key 14X9X70	2	2001	400 Impeller	2
2011	Half connector	1			

## 16.2 SUB-ASSEMBLY: HEAD AND COLUMN ASSEMBLY

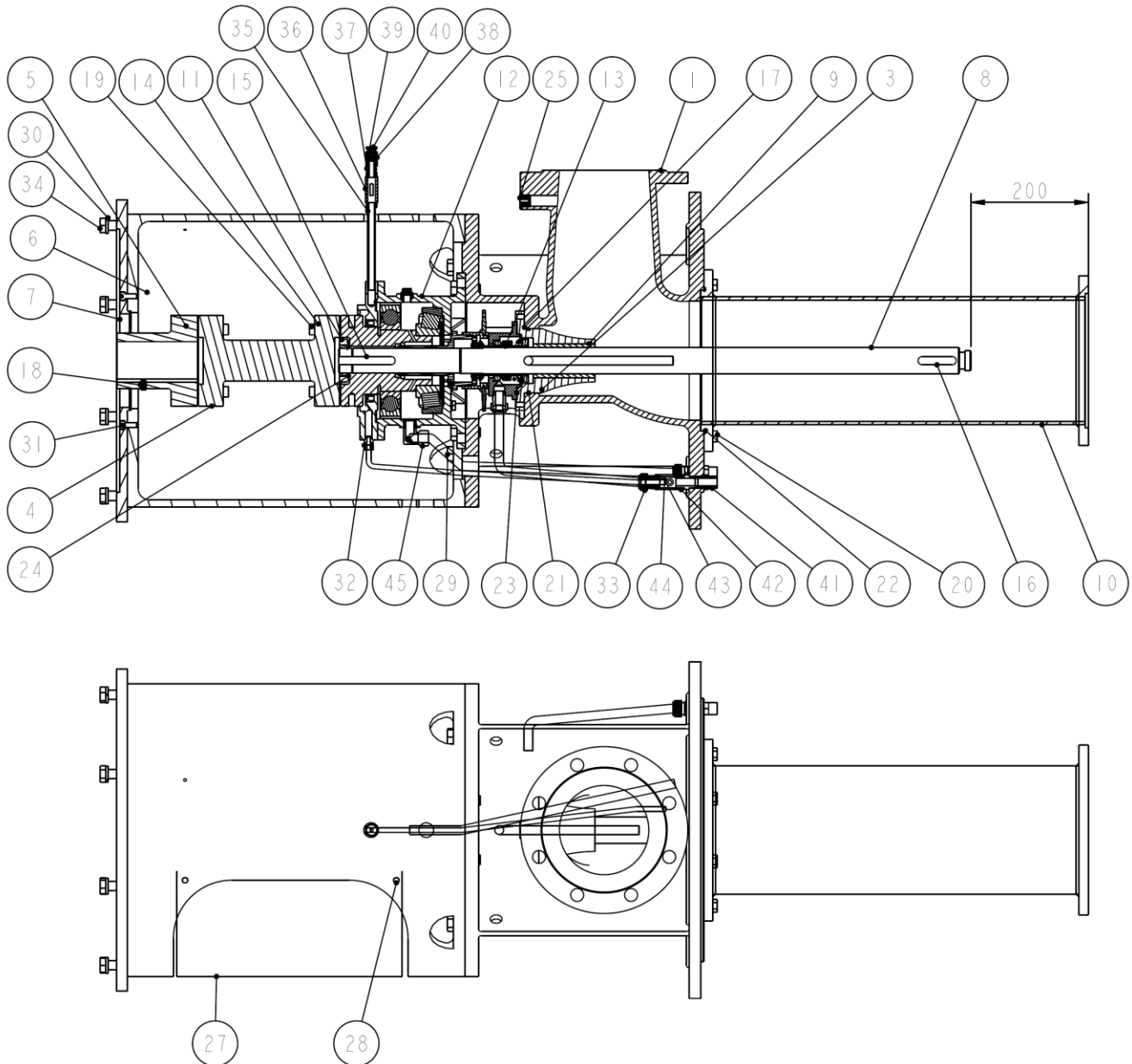

No.	Description	Qty	No.	Description	Qty
1	head	1	25	1/2"plug and 1/2" change nipple	1
3	packing box	1	27	coupling guard	1
4	spacer coupling	1	28	bolt M6x25, and washer M6	4
5	motor coupling	1	29	bolt M16x40	4
6	motor bracket	1	30	washer for motor	8
7	intermediate plate	1	31	bolt for intermediate plate	8
8	top shaft	1	32A	hexagon nipple 1/4"xØ8	1
9	bearing	1	32B	Tube pipe Ø8x1.0	0.5
10	column	1	33A	hexagon nipple 1/2"xØ15	5
11	lock nut	1	33B	Tube pipe Ø15x1.0	2
12	bearing assembly unit	1	34	Bolt for motor	8
13	mechanical sealing unit	1	35	Connecting nipple 1/4"x150	1
14	coupling bush	16	36	Flow indicator	1
15	key A 14x9x70	1	37	Hexagon nipple 1/4"x1/4"	1
16	key A 14x9x65	1	38	Connecting sleeve 1/4"	1
17	bolt M8x25	4	39	Orifice nozzle	1
18	point screw M10x16	1	40	Plug 1/4"	1
19	allen screw M12x60	16	41	Hexagon nipple 1/2"x1/2"	4
20	bolt M16x40	12	42	Tee 1/2"x1/2"x1/2"	1
21	O-ring 103x3.55	1	43	Nipple 1/2"x1/4"	1
22	O-ring 320x5.3	1	44	Male elbow 1/4"xØ8	1
23	oil paper gasket 130x92x0.2	1	45	Male elbow 1/2"xØ15	1
24	self lock washer 42	1			

## 16.3 SUB-ASSEMBLY: MECHANICAL SEALING UNIT

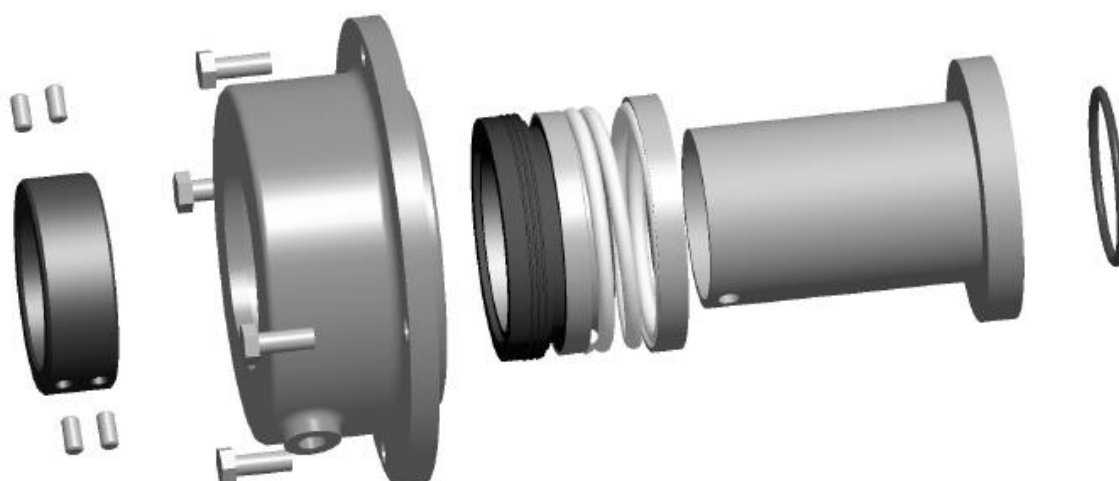
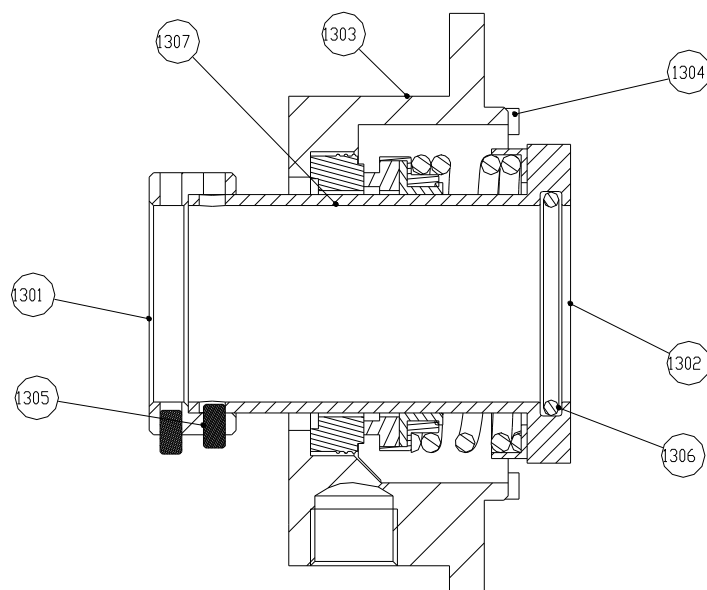

No.	Description	Quantity
1307	Mechanical seal 50	1
1306	O-ring	1
1305	Point screw M5X10 Din916	4
1304	Bolt M6X16 Din933	4
1303	Seal seat	1
1302	Seal adjuster	1
1301	Sleeve locker	1

## 16.4 SUB-ASSEMBLY: BEARING ASSEMBLY UNIT

**Type 1**  
(Used in DL300, DL300B, DL400)

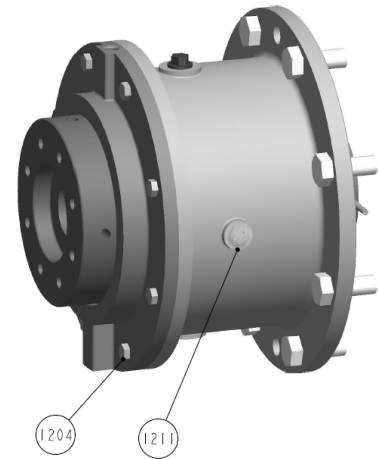
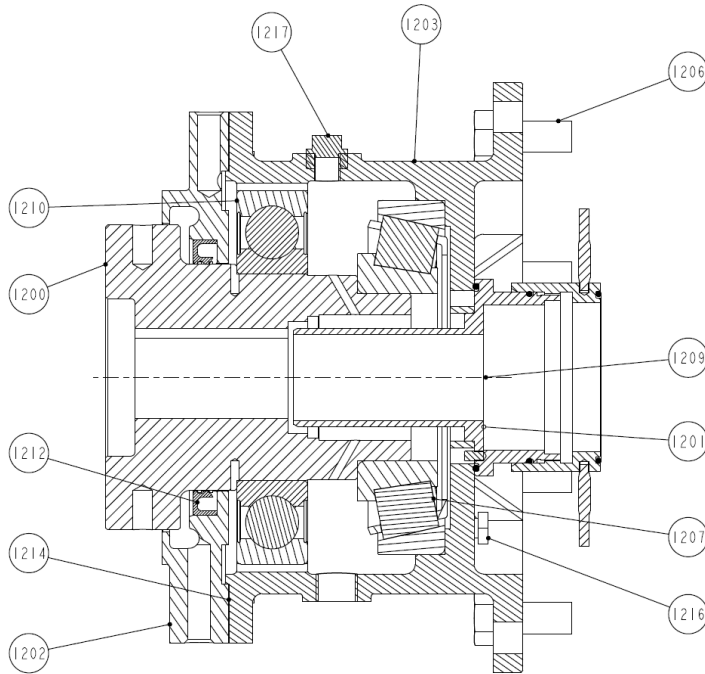

No.	Description	Qty	No.	Description	Qty
1217	plug 1/2" BSP	1	1207	Thrust bearing 31317	1
1216	Bolt M10x16, and dubo-washer M10	4	1206	Bolt M16X40	8
1214	Oil paper 270X212X0.2	1	1204	Bolt M8X25	8
1212	Labyrinth ring	1	1203	Bearing box	1
1211	Oil glass A10 JB/T7941.2	1	1202	Bearing box cover	1
1210	Bearing 6221	1	1201	Oil tube assembly unit	1
1209	Plug 1/4"	3	1200	Support coupling	1

## Type 2 (Used in DL400B)

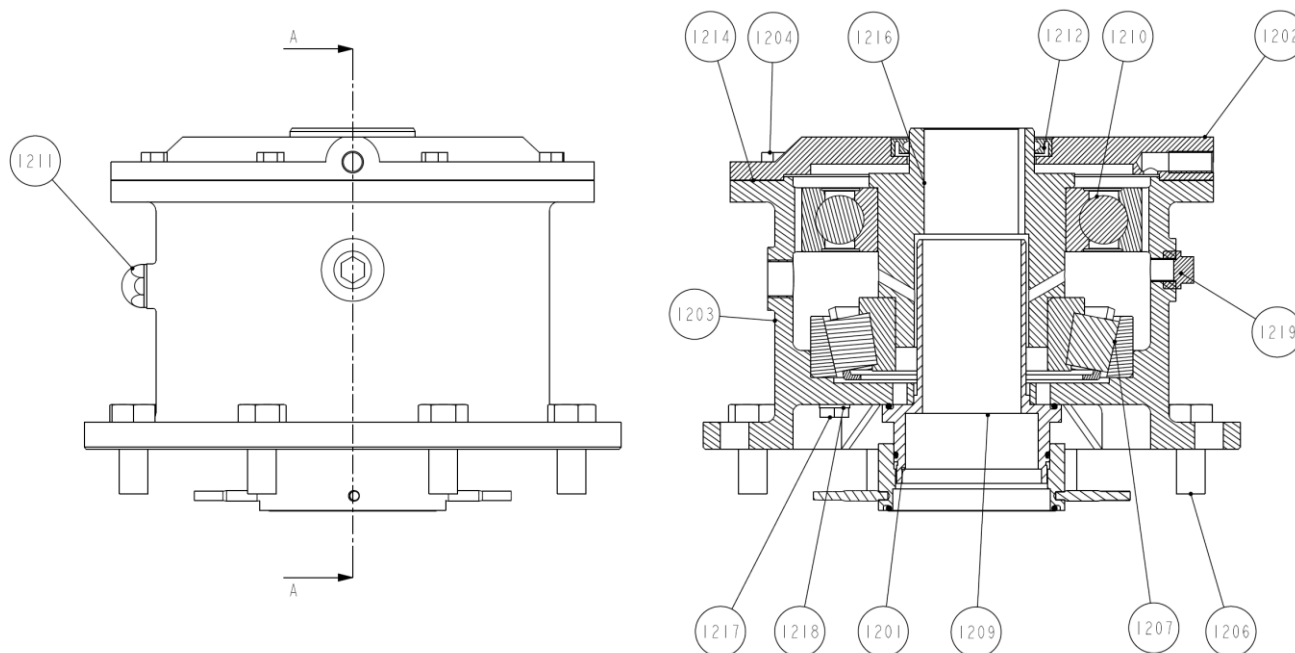

No.	Description	Qty	No.	Description	Qty
			1210	Bearing 6221	1
1219	Plug 1/2" BSP	1	1209	Plug 1/4"	2
1218	Dubo-washer M10	4	1207	Thrust bearing	1
1217	Bolt M10x16	4	1206	Bolt M16x40 and Washer M16	8
1216	Support coupling	1	1204	Bolt M8x20	8
1214	Oil paper Ø270xØ212x0.2	1	1203	Bearing box	1
1212	Oil seal FB70x90x10	1	1202	Bearing box cover	1
1211	Oil glass A10 JB/T7941.2 AL	1	1201	Oil tube assembly unit	1