

Mobile Fire & Emergency Bilge Pumps

Easy handling onboard vessels



SA50T
 Engine sizes:
 Type 1B20, 3.4 kW at 3600 rpm
 Type 1B30, 5.0 kW at 3600 rpm
 Capacity: 24 m³/h x 26 mLC.



S70-50-175/A11 for quick priming
 Capacity: 20-50 m³/h x 55-20 mLC.



Capacity curves for mobile fire pumps

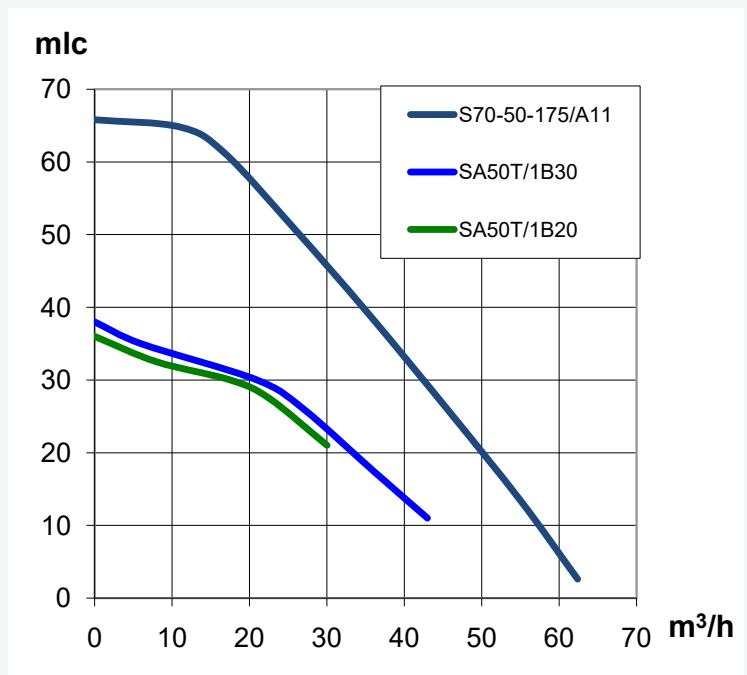

For more information on Marine & Offshore solutions, please visit www.desmi.com



Mobile Fire & Emergency Bilge Pumps

SA50T Super is equipped with a special star wheel which is placed behind the impeller. This solution ensures quick and safe priming. The priming time at 4 metres suction head and 2" suction hose is approx. 20 seconds.

All SA50T pumps are available in a watertight aluminium box complete with suction and pressure hoses.

DESMI has an extensive product range of mobile and stationary diesel-driven pump units. These pump units are made to comply with the demands of the marine industry as regards materials, design, and ease of handling.

SA50T is a mobile emergency fire and bilge pump which weighs as low as 50 kg. This lightweight pump is specially designed for easy handling on board vessels.

Type	Wet	Dry
SA50T/Hatz 1B20, Recoil start	57 kg	50 kg
SA50T/Hatz 1B20, Electric & recoil start	65 kg	58 kg
SA50T/Hatz 1B30, Recoil start	69 kg	55 kg
SA50T/Hatz 1B30, Electric & recoil start	72 kg	63 kg
SA50T/Super 1B30, Recoil start	69 kg	55 kg
SA50T/Super 1B30, Electric & recoil start	83 kg	72 kg

The construction is based on the well-known DESMI SA pump series. The pump casing is made of seawater resistant aluminium and the impeller of stainless steel. The pump is close coupled to a new-developed lightweight hand start Hatz diesel engine. Electric start is available as an option.

The pump unit is mounted in a stable carrying frame. The flanges of the pump are equipped with Storz C-2" couplings for quick and safe connection of the hoses. The low weight of the unit and the stable frame make it possible to move the pump around.

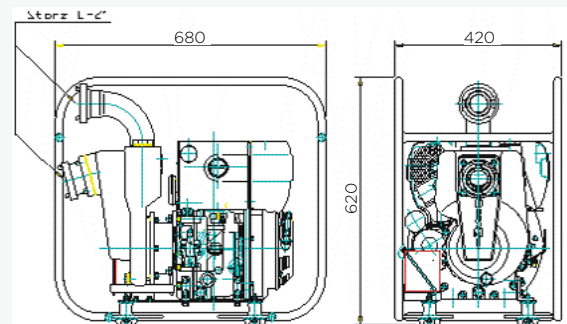

S70-50-175/A11 for quick priming

DESMI MODULAR-S Super-primer is the right solution when quick priming is required.

The priming ability of the pump is up to 12,000 litres of air per hour, dependent on suction lift. This very fast priming is achieved by a combination of the diffuser principle and the liquid ring principle where a star wheel from the liquid ring pump is mounted on the same shaft as the impeller.

The unit is mounted on a stable carrying frame with carrying handles. The pump is driven by a 2-cyl., 4-stroke Lombardini diesel engine of 12 kW with hand and electric start.

Type	Wet	Dry
S70-50-175/A11/Lombardini Electric & recoil start	155 kg	140 kg

The pump is equipped with 2½" suction and 2" pressure branches for quick and safe connection of the hoses.

