

INSTRUCTIONS FOR SPARE PARTS

Spare parts for DESMI vertical "in-line" centrifugal pump

NSL Monobloc without bearing

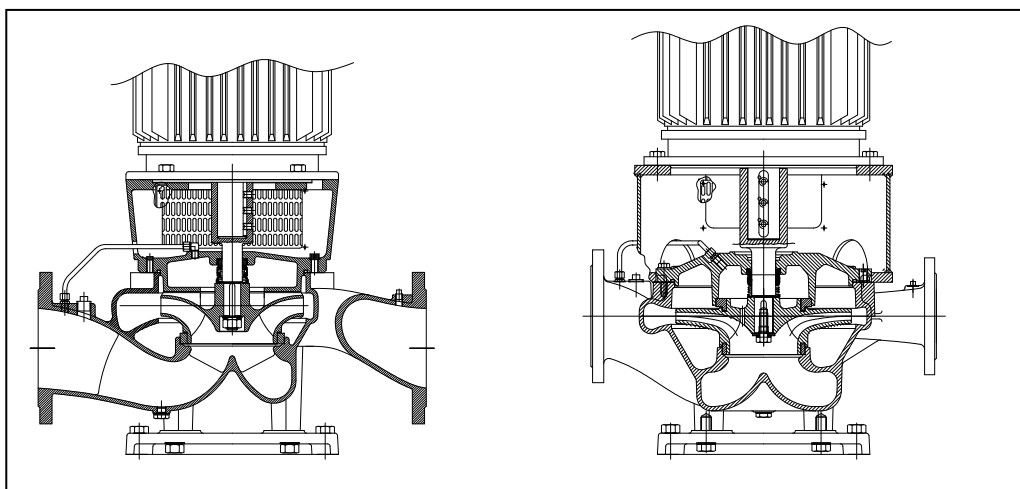

DESMI PUMPING TECHNOLOGY A/S

Tagholm I, DK-9400 Nørresundby, Denmark

Tel.: +45 96 32 81 11

Fax: +45 98 17 54 99

E-mail: desmi@desmi.com

Internet: www.desmi.com

Manual: T1510	Language: English	Revision: C (11/17)
------------------	----------------------	------------------------

Special pump No.



TABLE OF CONTENTS:PAGE
1. DISMANTLING (12 Combination) monobloc without bearing	3
1.1 ACCESS TO IMPELLER.....	3
1.2 DISMANTLING SHAFT SEAL	3
1.3 DISMANTLING SEAT.....	3
1.4 INSPECTION.....	3
1.5 DISMANTLING COUPLING / SHAFT.....	3
2. ASSEMBLING.....	4
2.1 FITTING SEALING RINGS.....	4
2.2 FITTING SHAFT SEAL	4
2.3 FITTING IMPELLER	4
2.4 FITTING MOTOR BRACKET (12-COMBINATION)	4
2.5 SHAFT	4
3. DISMANTLING	5
4. START-UP.....	5
5. ASSEMBLY DRAWING \varnothing 215/265 12-comb.....	6
6. SPARE PARTS LIST \varnothing 215/265 12-comb.....	6
7. ASSY. DRAWING \varnothing 330/415/525 12-comb.....	7
8. SPARE PARTS LIST \varnothing 330/415/525 12-comb.....	7
9. ASSEMBLY DRAWING NSL300-418 12-comb.....	8
10. SPARE PARTS LIST NSL300-418 12-comb.....	8
11. ASSEMBLY DRAWING NSL350-525 12-comb.....	9
12. SPARE PARTS LIST NSL350-525 12-comb.....	9
APPENDIX A.....	10

1. DISMANTLING (12 COMBINATION) MONOBLOC WITHOUT BEARING

1.1 ACCESS TO IMPELLER

The numbers in brackets refer to the position numbers on the assembly drawing.

ø215/265

Remove guards (28). Remove Allen screws (22) which hold the motor bracket (20) to the pump casing (1). Dismantle copper pipe (58). The top piece can now be lifted up allowing inspection of the impeller.

ø330/415/418/525

Remove guards (28). Remove set screws (64) which hold the motor bracket (20) to the pump casing (1). Dismantle copper pipe (58). Remove set screws (22) with washers (23), which hold the shaft seal cover (18) to the pump casing. Loosen the shaft seal cover from the pump casing by means of the pointed screws (86). The motor and motor bracket with shaft seal cover and shaft with impeller can now be lifted up allowing inspection of the impeller.

1.2 DISMANTLING SHAFT SEAL

ø215/265

Remove nut (6). Pull off the impeller (5), and remove sunk key (9). Remove set screws (71) and pull motor bracket and electric motor with shaft (17) apart, by which the shaft seal is pulled off the shaft.

ø330/415/418/525

Remove set screw (6). Pull off the impeller, and remove sunk key (9). Pull shaft seal cover out of motor bracket, by which the shaft seal (10) is pulled off the shaft.

1.3 DISMANTLING SEAT

Press out the seat from behind the motor bracket (ø215/265 in 12-combination)

1.4 INSPECTION

When the pump has been dismantled, check the following parts for wear and damage:

- Sealing ring/impeller: Max. clearance 0.4-0.5 mm measured in radius.
- Shaft seal/shaft seal cover: Check the seat for flatness and cracks.
Check the rubber parts for elasticity.
- Bearings: Replace in case of wear and noise.

1.5 DISMANTLING COUPLING / SHAFT

In the 12-combination the shaft must be removed when the lower bearing in the electric motor is replaced.

Remove pointed screws (73). Pull off the shaft. . The coupling might be heated to facilitate dismantling.

2. ASSEMBLING

2.1 FITTING SEALING RINGS

When fitted, the sealing ring (4) is to bear against the shoulder of the pump casing.

ø330/415/418/525

When fitted the sealing ring (27) is to bear against the shoulder of the shaft seal cover (20).

2.2 FITTING SHAFT SEAL

For pumps with balanced shaft seal type ELK (= "L" included in pump code on name plate) please read appendix A.

Before fitting the seat, clean the recess in the motor bracket. When fitting the seat, remove the protective coating without scratching the lapped surface. Dip the outer rubber ring of the seat into soapy water. Now press the seat into place with the fingers and check that all parts are correctly imbedded.

If it is necessary to use tools for assembling, then protect the sliding surface of the seat to prevent it from being scratched or cut. Lubricate the inner surface of the slide ring rubber bellows with soapy water and push it over the shaft. The use of a conical fitting bush as shown on the assembly drawing is recommended to avoid that the rubber bellows is cut.

Push the slide ring over the shaft with the hand. If the rubber bellows is tight, use a fitting tool and take care that the slide ring is not damaged. If the carbon ring is not fixed, it is important to check that it is fitted correctly, i.e. the chamfered/lapped side is to face the seat. The carbon ring can be held by a little grease.

When using soapy water on the shaft, the bellows will settle and seat in abt. 15 minutes, and until then tightness should not be expected. After start, check by viewing the leak hole that there are no leaks.

2.3 FITTING IMPELLER

Fit the sunk key in the shaft and lead the impeller towards the shoulder of the shaft. Take care that the ring at the end of the shaft seal spring locates in the recess of the impeller. Secure the impeller with washers (7 and 8) and a nut (ø215/265) or a set screw (ø330/415/525) or a nut and stud (300-418/350-525).

2.4 FITTING MOTOR BRACKET (12-COMBINATION)

Place the O-ring (21) between pump casing and (or motor bracket in ø215/265 12 combination) in the O-ring groove and hold it with a little grease. However, check the material of the O-ring first. As standard the material is nitrile, but it might be EPDM which will be damaged by mineral grease. Use soft soap or silicone grease for EPDM. Fit and fasten motor bracket, mounted with the electric motor, in the pump casing. Screw the pointed screws (86) back into the shaft seal cover before tightening. Fit copper pipe (58).

2.5 SHAFT

When the pump has been assembled, check that the shaft rotates freely. In case the shaft has been dismantled in the 12-combination, tap the shaft towards the shaft end of the electric motor by means of a plastic hammer, and fasten the pointed screws (first the middle screw) according to the below table. Check that the wobble, measured as close to the shaft end as possible, is within the limits indicated in the table.

Motor size	Dimension Pointed screws	Torque Pointed screws	Max. wobble
100/112	M6	10 Nm	70 µm
132	M8	24 Nm	70 µm
160	M10	40 Nm	70 µm
180	M12	55 Nm	70 µm
200	M12	75 Nm	70 µm
225	M16	160 Nm	70 µm
250	M16	160 Nm	70 µm
280	M16	160 Nm	70 µm
315	M16	160 Nm	70 µm
315 / 355	M20	320 Nm	70 µm

3. DISMANTLING



Before dismantling the pump make sure that it has stopped. Empty the pump of liquid before it is dismantled from the piping system. If the pump has been pumping dangerous liquids you are to be aware of this and take the necessary safety measures. If the pump has been pumping hot liquids, take great care that it is drained before it is removed from the piping system.



4. START-UP

A centrifugal pump will not function until it has been filled with liquid between the foot valve and somewhat above the impeller of the pump.

The liquid also serves as coolant for the shaft seal. In order to protect the shaft seal the pump must not run dry.

5. ASSEMBLY DRAWING Ø215/265 12-COMB.

6. SPARE PARTS LIST Ø215/265 12-COMB.

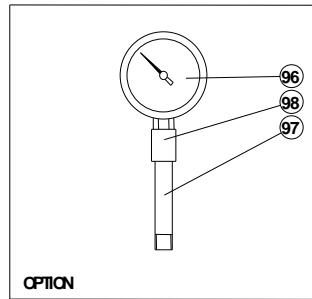

- 1 Pump casing
- 2 Pipe plug
- 3 Pipe plug
- 4 Sealing ring
- 5 Impeller
- 6 Nut
- 7 Spring collar
- 8 Washer
- 9 Sunk key
- 10 Mech. shaft seal
- 17 Shaft
- 20 Motor bracket
- 21 O-ring
- 22 Allen screw
- 28 Guard
- 58 Copper pipe
- 59 Hexagon nipple
- 71 Set screw
- 73 Pointed screw
- 75 INSEX-screw
- 81 Sealing washer
- 93 Set screw
- 94 Base plate
- 95 Lock washer
- 96 Manometer
- 97 Nipple
- 98 Sleeve
- 107 Pipe plug

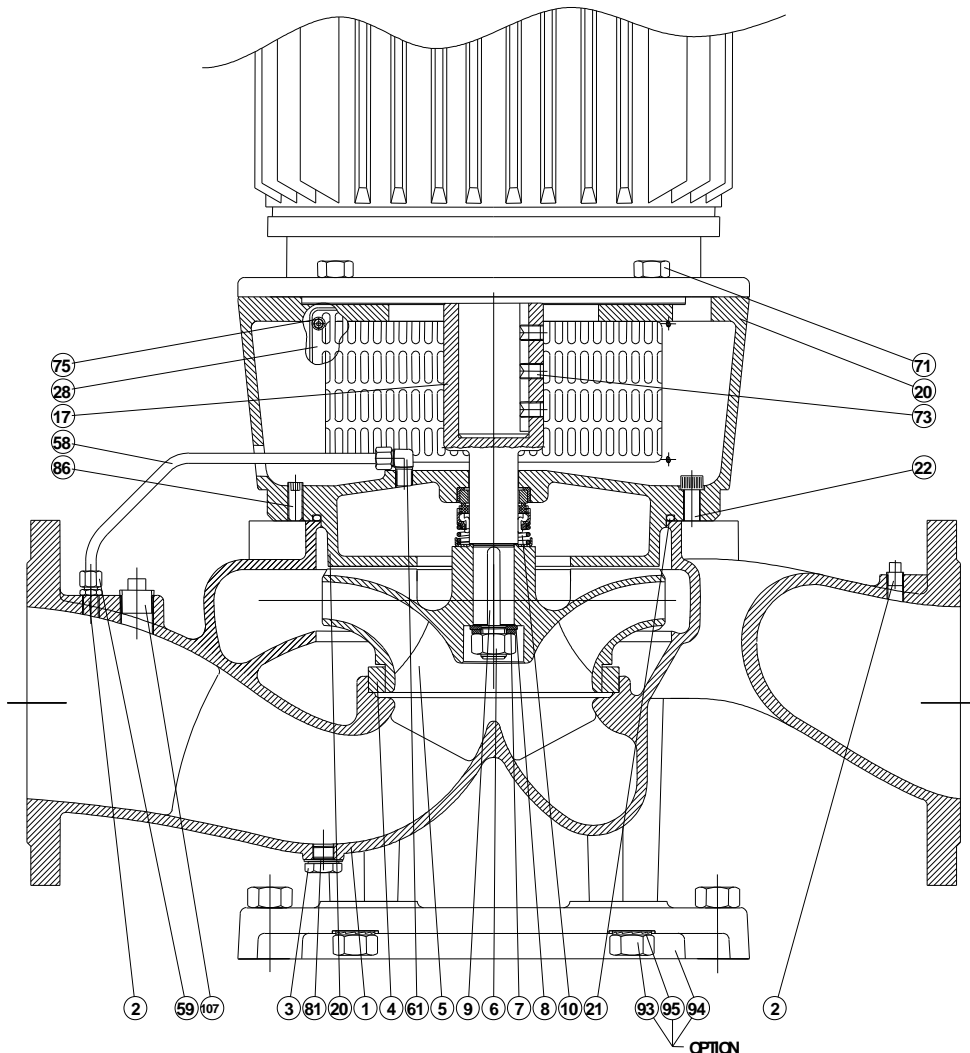

DESMI PUMPING TECHNOLOGY A/S

Tagholm 1
 9400 Nørresundby – Danmark
 Tlf. nr.: +45 96 32 81 11
 Fax +45 98 17 54 99
 E-mail: desmi@desmi.com

7. ASSY. DRAWING Ø330/415/525 12-COMB.

8. SPARE PARTS LIST Ø330/415/525 12-COMB.

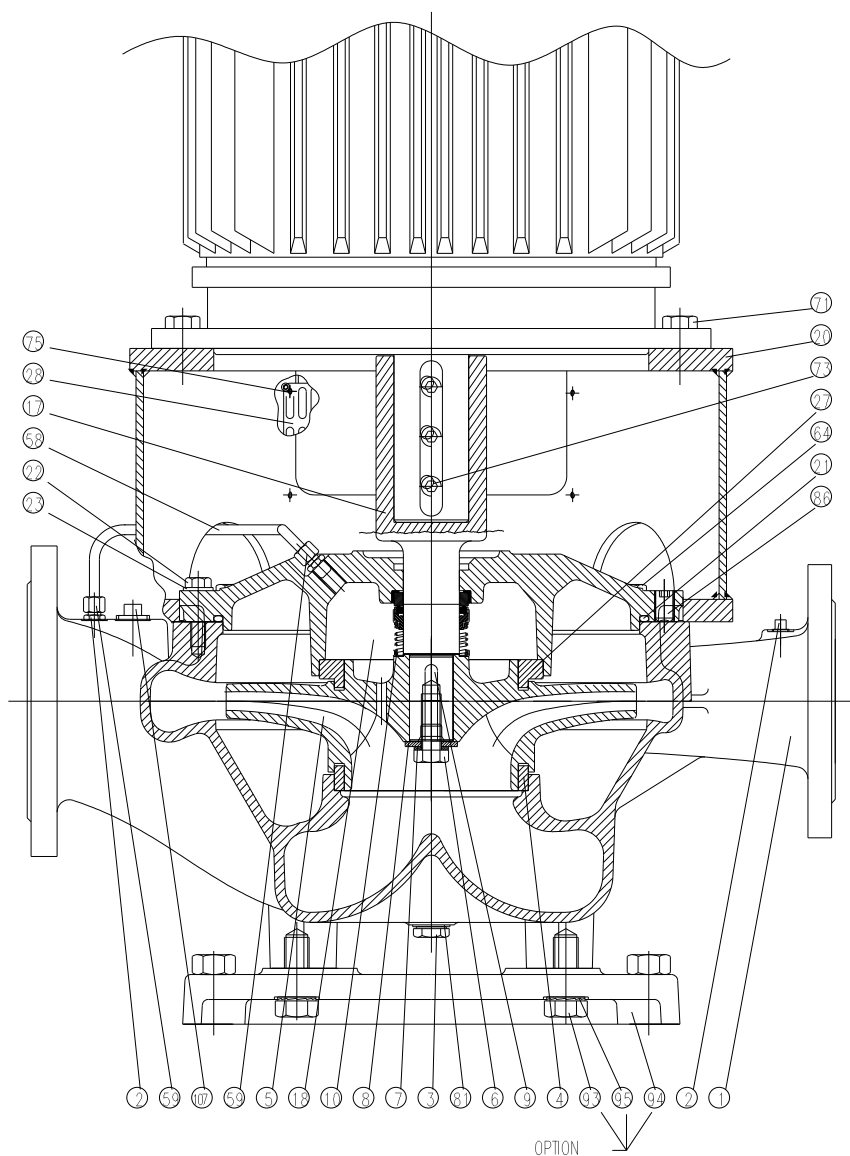
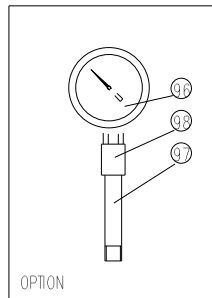

- 1 Pump casing
- 2 Pipe plug
- 3 Pipe plug
- 4 Sealing ring
- 5 Impeller
- 6 Set screw
- 7 Spring collar
- 8 Washer
- 9 Sunk key
- 10 Mech. shaft seal
- 17 Shaft
- 18 Shaft seal cover
- 20 Motor bracket
- 21 O-ring
- 22 Set screw
- 23 Lock washer
- 27 Sealing ring 2
- 28 Guard
- 58 Copper pipe
- 59 Hexagon nipple
- 64 Set screw
- 71 Set screw
- 73 Pointed screw
- 75 INSEX-screw
- 81 Sealing washer
- 86 Pointed screw
- 93 Set screw
- 94 Base plate
- 95 Lock washer
- 96 Manometer
- 97 Nipple
- 98 Sleeve
- 107 Pipe plug

DESMI PUMPING TECHNOLOGY A/S

Tagholm 1
 9400 Nørresundby – Danmark
 Tlf. nr.: +45 96 32 81 11
 Fax +45 98 17 54 99
 E-mail: desmi@desmi.com

www.desmi.com

9. ASSEMBLY DRAWING NSL300-418 12-COMB.

10. SPARE PARTS LIST NSL300-418 12-COMB.

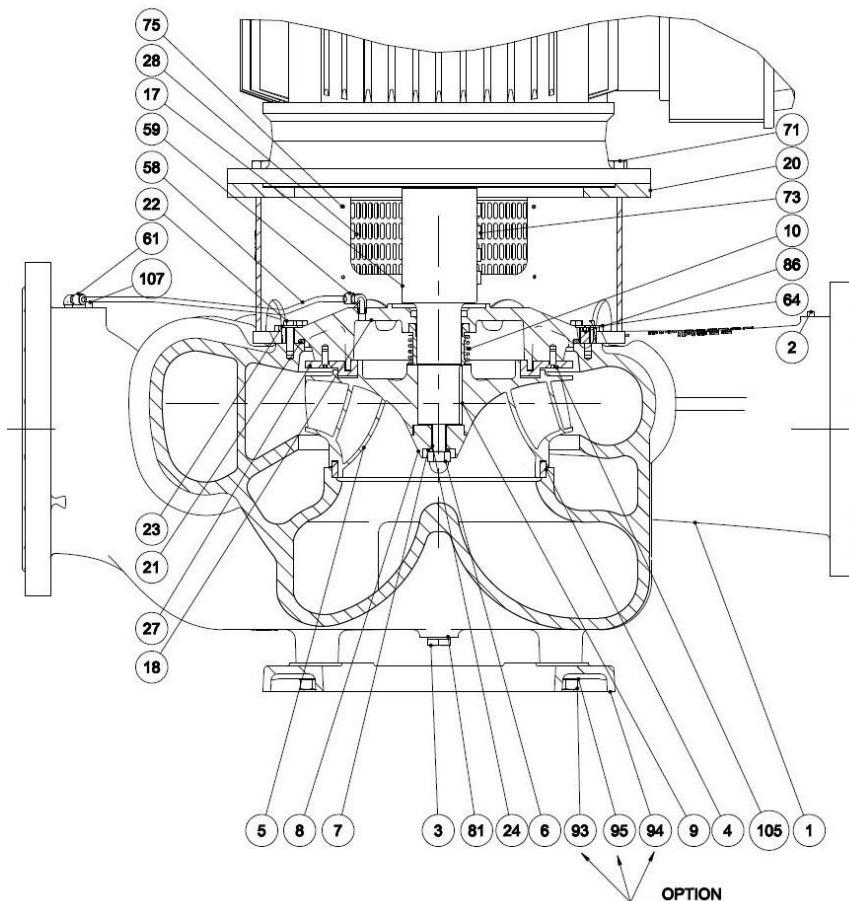
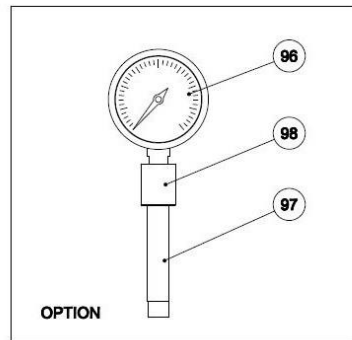

- 1 Pump casing
- 2 Pipe plug
- 3 Pipe plug
- 4 Sealing ring
- 5 Impeller
- 6 Cap nut
- 7 Spring washer
- 8 Inlet cone
- 9 Sunk key
- 10 Mech. shaft seal
- 17 Shaft
- 18 Shaft seal cover
- 20 Motor bracket
- 21 O-ring
- 22 Set screw
- 23 Lock washer
- 24 Stud
- 27 Sealing ring 2
- 28 Guard
- 58 Copper pipe
- 59 Hexagon nipple
- 61 Hexagon nipple
- 64 Set screw
- 71 Set screw
- 73 Pointed screw
- 75 INSEX-screw
- 81 Sealing washer
- 86 Pointed screw
- 93 Set screw
- 94 Base plate
- 95 Lock washer
- 96 Manometer
- 97 Nipple
- 98 Sleeve
- 105 Countersunk screw
- 107 Pipe plug

DESMI PUMPING TECHNOLOGY A/S

Tagholm 1
 9400 Nørresundby – Danmark
 Tlf. nr.: +45 96 32 81 11
 Fax +45 98 17 54 99
 E-mail: desmi@desmi.com

11. ASSEMBLY DRAWING NSL350-525 12-COMB.

12. SPARE PARTS LIST NSL350-525 12-COMB.

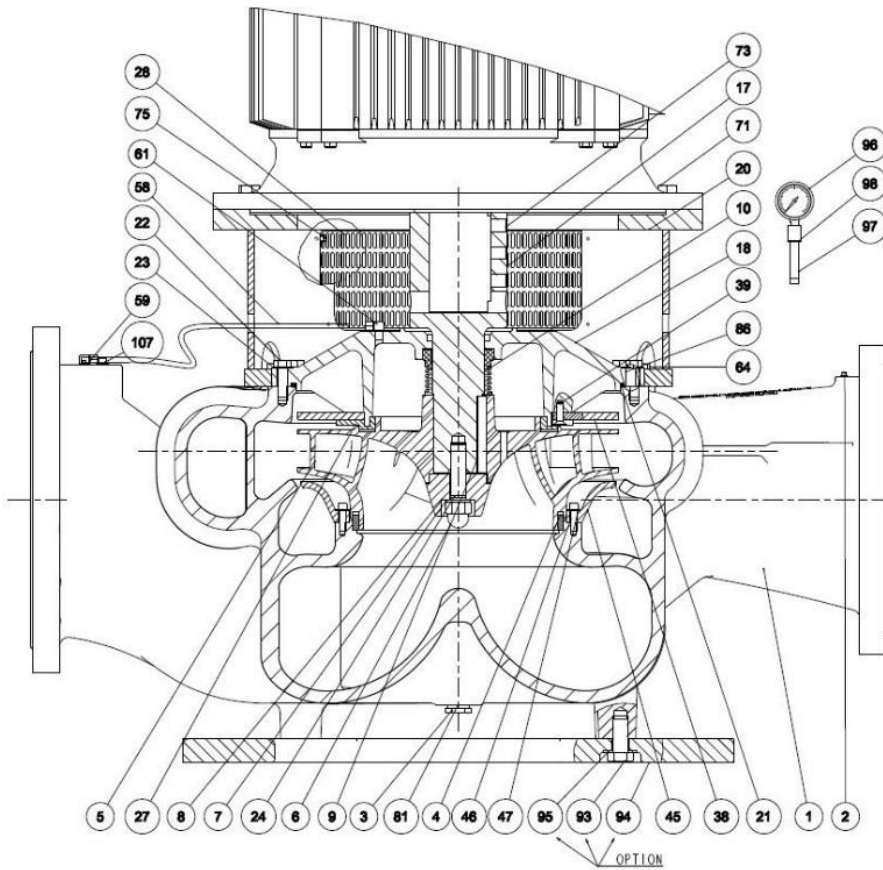

- 1 Pump casing
- 2 Pipe plug
- 3 Pipe plug
- 4 Sealing ring
- 5 Impeller
- 6 Cap nut
- 7 Spring washer
- 8 Inlet cone
- 9 Sunk key
- 10 Mech. shaft seal
- 17 Shaft
- 18 Shaft seal cover
- 20 Motor bracket
- 21 O-ring
- 22 Set screw
- 23 Lock washer
- 24 Stud
- 27 Sealing ring 2
- 28 Guard
- 38 Guard plate
- 39 Countersunk screw
- 45 Guard Plate
- 46 Screw
- 47 Washer
- 58 Copper pipe
- 59 Hexagon nipple
- 61 Hexagon nipple
- 64 Set screw
- 71 Set screw
- 73 Pointed screw
- 75 INSEX-screw
- 81 Sealing washer
- 86 Pointed screw
- 93 Set screw
- 94 Base plate
- 95 Lock washer
- 96 Manometer
- 97 Nipple
- 98 Sleeve
- 107 Pipe plug

APPENDIX A

FITTING OF ELK SHAFT SEAL

Check length from motor shaft end to motor flange being within +/- 0.5mm of the nominal length (like 60, 80, 110, 140 and 170 mm).

If the motor shaft is too short then fit a pointed screw glued into the motor shaft end to adjust the pump shaft to correct mounting position – in order to ensure correct build in length for the ELK shaft seal.

If the motor shaft is too long then it has to be machined / milled to nominal length.

It has to be checked if the shaft sealing have the correct length when mounted on the pump shaft as shown below. I.e. there shall always be 44.5 +/- 0.5mm from sliding surface on the seat to the end of the rotating part, on the sizes of ELK sealing used by DESMI. Please observe that the rotating part protrudes 2 mm beyond the shoulder on the pump shaft as shown below.

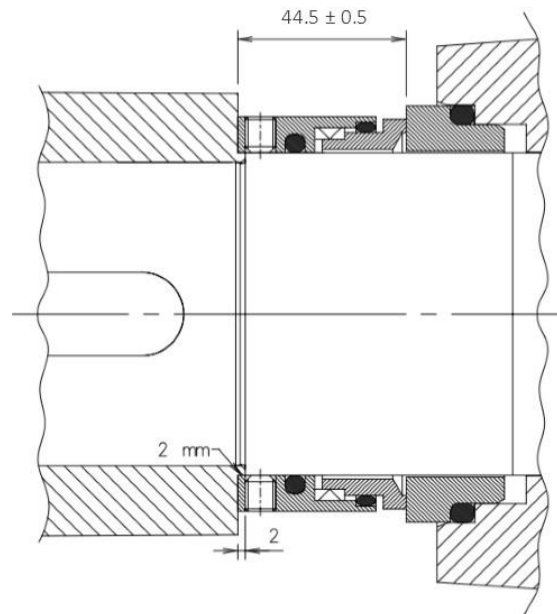

Also make sure that the electric motor is with locked bearing in the drive end – i.e. there must not be forced axial stroke of the electric motor.

Notice ! Never use mineral oil / fat as grease, as rubber parts as standard are in EPDM.

Notice ! Never put grease on the sliding surfaces! They must be completely dry, dust-free and clean during the mounting procedure. Also any fingerprints shall be removed with alcohol or another suitable solvent.

Notice: ELK shaft seals must be turned after installation ... so O-rings, springs and sliding surfaces can slip into right placement before pressure testing. This is done by mounting the seal as described and later turn the shaft about 10 revolutions - with water in the pump - but without adding pressure. Then pressure test the pump as normally done.