

DES 340 – 365 FWB - HIFR

The DES 340 – 365 FWB - HIFR (Filter Water Barrier - Helicopter In-Flight Refueling) dispenser modules consist of the essential parts to refuel/defuel helicopters with JP-5 (F-44) on hangar or in flight.

The modules are capable to deliver dry/clean-filtered JP-5 fuel into a helicopter with different fueling options.

Following sizes of dispenser modules appears below:

- DES 340 – HIFR
- DES 350 – HIFR
- DES 365 – HIFR



The modules can either be built according to DNV GL (RU-SHIP), ABS or Lloyd's Register rules. The system consists generally of the following main components:

- 1 x Hose reel, electrical rewind
- 1 x 37-meter non-collapsible aviation fuel hose
- 1 x Flushing line for gravity- and underwing nozzle
- 1 x 37-meter bonding reel, spring rewind
- 1 x Bulk meter
- 1 x Air driven membrane pump for defueling (up to 160 L/min)
- 1 x Pressure reducing valve
- 2 x Sample point
- 1 x Deadman handle
- 1 x Dispenser Control Panel (DCP) with 12" HMI touch display
- 1 x FWB included necessary instrumentation
- 1 x HIFR assembly + Lay flat hose
- 1 x Set of nozzles (Gravity- & Underwing nozzle)
- Instrumentations based on DESMI's recommendation
- 1 x Base frame with integrated drip tray

DES 340 - 365 FWB - HIFR

HIFR assembly options:

HIFR-Kit assembly according to STANAG 3847 E.d.2. Two options below (1 & 2):

Option 1:

- 2.5" FWB - HIFR deckpoint BSP NPT
- 2.5" FWB - HIFR helipoint
- 1/2" NPT F-F CONNECTOR
- Unisex coupling valved 2" BSP
- Breakaway coupling 2.5" 400 - 500 lb
- Te Green Pin Bow Shackle G-4631
- Non-Collapsible Hose PHD-F 50
- GROUNDING PLUG/CLIP CABLE ASSY
- Unisex coupling non-valved female 2.5" BSP
- Non-return valve
- Collapsible Hose FHD 50 Cu 30 m M-M



Option 2:

- HIFR Deckpoint
- HIFR Helipoint
- Unisex coupling valved
- Upper dry-break breakaway coupling (break force 400 - 500 lbf. / 180 - 230 kg)
- Shackles for lifting / fixing
- Non-collapsible 2" aviation fuel hose (2.2 meters)
- Grounding wire w/ clamp and plug
- Unisex coupling non-valved
- Lower dry-break breakaway coupling (break force 250 lbf. / 113 kg)
- Non-return valve
- Collapsible 2" aviation fuel hose (30 meters)

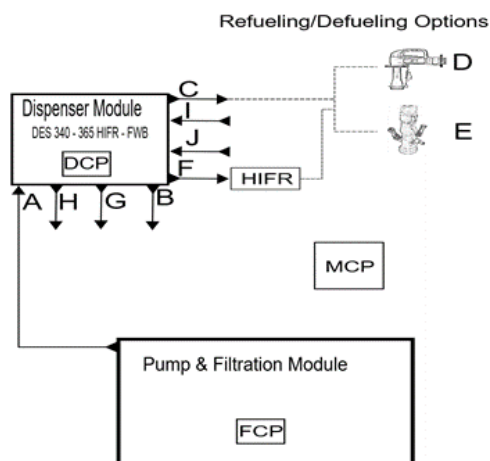

Interfaces of Pump & Filtration Module

A: Inlet aviation fuel service

B: Outlet defuel

C: Fuel delivery hose with nozzle connection

D: Gravity nozzle

E: Underwing nozzle

F: FWB - HIFR outlet

G: Drain & overflow of FWB

H: Outlet flushing

I: Inlet compressed air

J: Inlet flushing

Technical Data:

Fuel Media:	JP-5 Fuel (NATO Code F-44)
Temperature Range:	Internal Compartment Range 0 - 48 °C
Working Pressure:	8,5 bar
EX-Protection Area:	Zone II

Flow rates:

- DES 340 FWB - HIFR, Flow:
150 - 230 L/min, Main size: DN 40
- DES 350 FWB - HIFR, Flow:
250 - 380 L/min, Main size: DN 50
- DES 365 FWB - HIFR, Flow:
380 - 680 L/min, Main size: DN 65

Dimensions & weights:

- DES 340 FWB - HIFR: Dimensions:
H x L x W = 1788 x 1300 x 1400, Weight = 900 kg
- DES 350 FWB - HIFR: Dimensions:
H x L x W = 1788 x 1400 x 1500, Weight = 995 kg
- DES 365 FWB - HIFR: Dimensions:
H x L x W = 1788 x 1550 x 1700, Weight = 1130 kg