

DES 250 P&F – DES 280 P&F

The pump & filtration modules DES 250 P&F – DES 280 P&F are duplex pipeline systems (service- and transfer systems).

Both systems are capable of pumping filtered dry and clean JP-5 (F-44) to required destination. Furthermore, it is possible to pump unfiltered fuel to required destination as well.

Following modules are available:

- DES 250 P&F
- DES 265 P&F
- DES 280 P&F



The modules can either be built according to DNV GL (RU-SHIP), ABS or Lloyd's Register rules. The system consists generally of the following main components:

- 2 x Electrical motor: 11 kW, 15 kW, 18 kW
- 2 x Vane pump
- 2 x Y - strainer
- 1 x Pressure relief valve
- 2 x Filter water separator (FWS)
- 1 x Filter control panel (FCP) with 12" HMI touch display
- Multiple valves
- Instrumentation based on DESMI A/S recommendations
- 1 x Base frame with integrated drip tray

DES 250 P&F - DES 280 P&F

Technical Data:

Fuel Media:	JP-5 Fuel (NATO Code F-44)
Temperature Range:	Internal Compartment Range 0 - 48 °C
Working Pressure:	8,5 bar
EX-Protection Area:	Zone II

Flow rates:

- DES 250 P&F, Flow rate:
150 - 230 L/min, Main size: DN 50
- DES 265 P&F, Flow rate:
250 - 380 L/min, Main size: DN 65
- DES 280 P&F, Flow rate:
380 - 680 L/min, Main size: DN 80

Dimensions & weights:

- DES 250 P&F: Dimensions:
H x L x W = 2042 x 1756 x 1875
Weight = 2157 kg
- DES 265 P&F: Dimensions:
H x L x W = 2042 x 2100 x 1875
Weight = 2442 kg
- DES 280 P&F: Dimensions:
H x L x W = 2050 x 2390 x 1805
Weight = 2550 kg

Flow Chart:

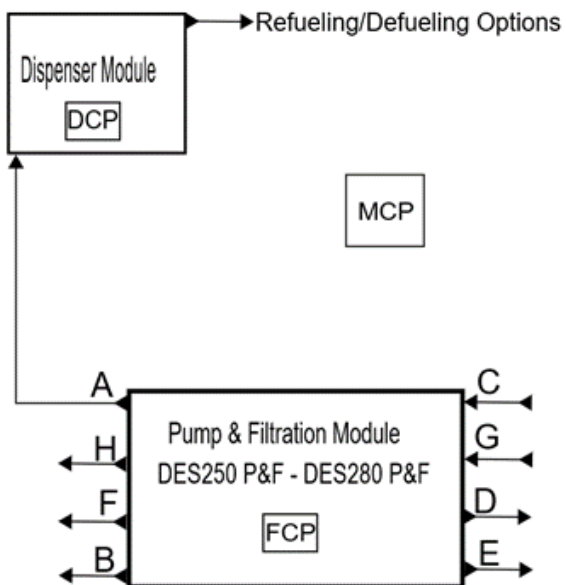

Interfaces of Pump & Filtration Module

- A: Outlet aviation fuel service
- B: Outlet aviation fuel transfer
- C: Inlet aviation fuel service
- D: Pressure relief valve return to tank
- E: Drain & overflow of FWS
- F: Outlet without filtration
- G: Inlet aviation fuel transfer